

Beghelli

The Beghelli Group

IL GRUPPO BEGHELLI



Introduction

Founded in 1982 by Gian Pietro [Beghelli](#), the [Beghelli Group](#) is an Italian and European emergency lighting leader that also operates in the fields of energy saving lighting, electronic domestic, industrial and urban safety & security systems. The company's strategy is based on its ability to interpret market requirements. Over the years, investments in product quality and the [Beghelli](#) brand name recognition - familiar to 92.9% of the Italian population (Doxa source) - have contributed to establishing the group's name in its traditional business, guaranteeing the success of new product launches. In addition to focusing on the very high growth potential in Italy, the [Beghelli Group](#) has introduced international initiatives aimed at increasing exports.

Reliability

The [Beghelli](#) Group strongly believes in the value of research activities, to which it provides considerable investments, for the development of products featuring technologically advanced functional characteristics and cutting edge design. Product research constantly occupies 15% of design, engineering, testing and certification activities.

Emergency Lighting

Emergency lighting is the Group's traditional area of activity, where it enjoys a prominent position of technological and commercial leadership. [Beghelli](#) manufactures complete ranges of self-powered luminaries. Particular emphasis has been placed on products with autotest diagnostic systems, which are now considered the most advanced solutions to testing and maintenance requirements, in compliance with current standards.

The Group

[Beghelli](#) S.p.A. is the Group's parent company that is responsible for the strategies and industrial, commercial and financial coordination. In addition to the company offices and logistics center that serves the Italian and European markets, our Monteveglio premises are also the location of laboratory structures aimed at research and development, design, engineering, testing and certification of [Beghelli](#) products. The [Beghelli](#) Group, which has been listed on the Milan Stock Exchange since 1998, also includes six (6) other international research, production and trading companies. [Beghelli](#) Asia Pacific, [Beghelli](#) Canada, [Beghelli](#) Elplast in the Czech Republic, [Beghelli](#) Präzisa in Germany, [Beghelli](#) de Mexico, [Beghelli](#) China and [Beghelli](#) USA are all proud members of the [Beghelli](#) Group.

Beghelli Italy (5)

Beghelli USA

Beghelli Canada

Beghelli Mexico

Beghelli Czech Rep.

Beghelli Germany

Beghelli Asia Pacific

Beghelli China

Industrial Design Awards

The acclaim of our products is also partly due to the continuous research dedicated to developing the aesthetic and ergonomic properties of [Beghelli](#) products. The results of this commitment are demonstrated by the numerous national and international design honors.

Beghelli Projects

Tens of thousands of projects testify to [Beghelli's](#) leadership in the lighting industry. The most prestigious projects in which the company has been involved include historical contexts such as the Vatican Museums and Milan's La Scala Theater as well as the Moscow Conservatory; Rome, Geneva, Tipoli, Prague and Tel Aviv airports, McDonalds restaurants in Denmark, Russia and China, multiple American universities, the TIME AOL building in New York, the Waldorf Astoria in New York, several Disney resorts, NASA Cape Canaveral, US Coast Guard locations, the Four Seasons Hotel in Miami, the parliament in Sirte and Expo in Seville



SERVING OUR CUSTOMERS

Investments in human resources, technologies and continual training; has combined into creating the industries most effective customer service group. We are here before, during and after your project. Our single most important goal is to make your job and your clients job easier.



EMERGENCY LIGHTING

The past twenty five years have not just given Beghelli the experience to compete in the emergency lighting industry and provide the most complete offering of Life Safety products; it has also provided Beghelli with an endless canvas to create new, innovative, high performance products that provide a safer world.

Supporting our extensive line is our customer service group & product specialists. Providing complete project support including seminars, design layout services, on-site assistance and 24 hour service lines.



Table of Contents

Indoor Architectural Emergency



Aestetica 12



Bella 14



Deco 16



BBY 18



XLP 20



XLP-S3 22



Ecoo Luna 24



RSE 26



RTB 28



RDO 30

Wet Location Architectural Emergency



Luna 36



Luna XLR 38



Tempesta 40



Gran Luce 42



Stormguard 44

Industrial Application Emergency



ESM 50



Cubico 52



ESL 54



EST 56



HWE 58



LDT 60



EDT 62



HDT 64



VDR 66



HDZ 68



HDZ 70

Indoor Architectural Exits



VA4 76



VA5 78



XCL 80



BBY-C 82



APE 84



STX 86



STX-C 88



ATX 90



LC1 92



LC1-Ecco 94



OL2 96



OL2-TL 98



Cyclone 100



Micra 102

Industrial Application Exits



Fortezza 108



WLX 110



EVR 112



TSL 114



DLX 116

Remotes & Inverters



Remotes 122



LUCE 126



Inverters 127

Accessories

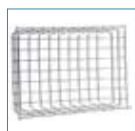

Accessories 140



Custom 141



Lamps 141



Batteries 143



Handheld 144

Technical Data



Technical 151

Indoor Architectural

Lighting

SECTION ONE



CONTENTS



Aestetica Series	
Linear fluorescent lamp: 8W	Page
Ceiling & wall installed product specifications. Damp Location.	12
Technical Data	13



Ecco Luna Series	
Halogen lamp: 8W-12W	Page
Ceiling & Wall installed product specifications. Damp location.	24
Technical Data	25



Bella Series	
Compact fluorescent lamp: 22W	Page
Ceiling & wall installed product specifications. Indoor only.	14
Technical Data	15



RSE Series	
Incandescent lamp: 7.2 - 18W	Page
Ceiling & Wall installed product specifications. Fully recessed.	26
Technical Data	27



Deco Series	
Incandescent lamp: 5.4 W	Page
Ceiling & Wall installed product specifications. Damp locations.	16
Technical Data	17



RTB Series	
Incandescent lamp: 7.2 - 50W	Page
Drop ceiling installed product specifications. T-Bar.	28
Technical Data	29



BBY Series	
MR-halogen lamp: 5W	
Ceiling & Wall installed product specifications. Damp location.	18
Technical Data	19



RDO Series	
Halogen lamp: 8W	
Ceiling installed product specifications. Recessed gimbal.	30
Technical Data	31



XLP Series	
Incandescent lamp: 5.4 - 9W	Page
Ceiling & Wall installed product specifications. Damp location.	20
Technical Data	21



XLPS3 Series	
Incandescent Lamp: 5.4 - 9W	Page
Ceiling & wall installed product specifications. Damp Location.	22
Technical Data	23



PRODUCT OVERVIEW

The **AESTETICA™** Series by Beghelli offers design, performance, ease of installation and reliability at a competitive commodity goods level. The compact and low profile design allows the **AESTETICA™** to be incorporated into the architecture of the installation. The injection molded ABS housing and clear Lexan diffuser insure durability, security and efficiency. Reliable and even light distribution is assured with the 8W linear fluorescent T5 lamp. The **AESTETICA™** is designed to be installed on wall and ceiling surfaces. Indoor installations only, damp location rated.

INTERNAL SPECIFICATIONS

AESTETICA™ features a multi input (120/277) transformer, brown-out and short-circuit protection and a fully automatic recharge circuit that is regulated by an electronic voltage sensor. Standard 4.8V 2.2Ah nickel-cadmium battery provides a minimum 120 minutes emergency duration and is protected by a low-voltage cut-off circuit.

EXTERNAL SPECIFICATIONS

The housing components are injection molded using corrosion and flame resistant ABS material. Designed to transmit as much light as possible during a power failure, the Lexan constructed diffuser is clear by design and has been UV stabilized to reduce yellowing. The housing color is natural, light gray. Internal connection clips insure the integrity of the **AESTETICA™**

INSTALLATIONS

The **AESTETICA™** Series is designed to be wall or ceiling surface mounted. Suitable for indoor/damp (IP40) installations. The internal housing connection clips securely hold the reflector and diffuser in place and discourage any tampering.

ORDERING INFORMATION

Series	Operation	Input Voltage
A8	SE (emergency only)	UNV (120/277V)

AESTETICA BUILDER

Series	Operation	Input Voltage

EXAMPLE: A8-SE-UNV
 DESCRIPTION: Aestetica emergency luminaire, emergency only, 120V/277V

JOB:	TYPE:
-------------	--------------

FLUORESCENT EMERGENCY

The use of fluorescent emergency is standard practice for Beghelli. The benefits are obvious; even light distribution, long lamp life, never having to worry if the lamps are positioned properly, increased fixture to fixture spacing, lighting the entire environment (rather than just the path of egress) and accurate photometrics. The **AESTETICA** does all this in a compact package.

LAMP TECHNOLOGY

The **AESTETICA** features a single 8W linear T5 lamp that is included. Estimated lamp life 7,500 hours.

AESTETICA PHOTOMETRICS:

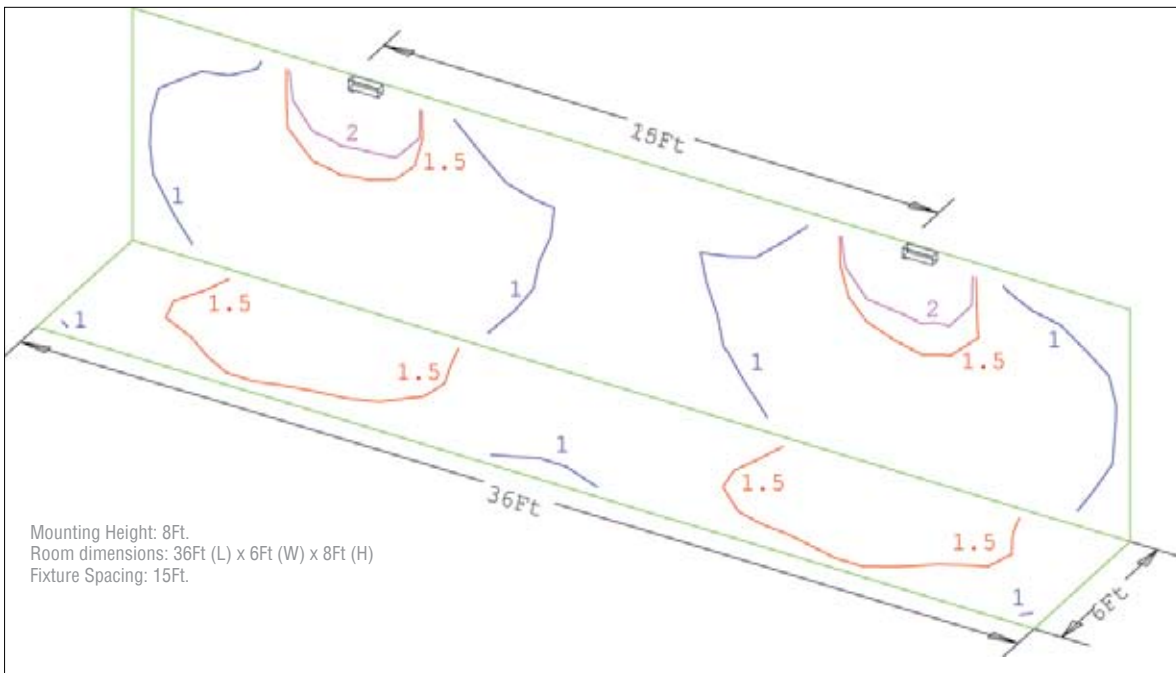

DIMENSIONS:

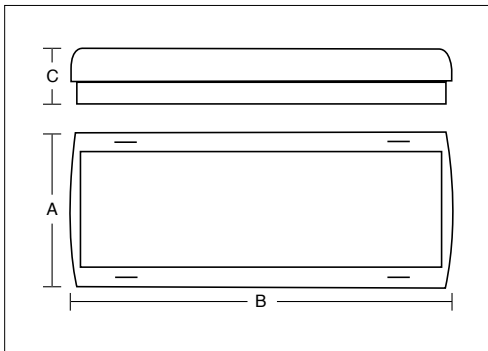

Series	A"	B"	C"
Aesthetic	5.3"	13.25"	1.8"

WARRANTY

The **AESTETICA** Series comes with a 5-year factory warranty. Lamps are not covered under the warranty. Deliberate damage, misuse, improper installation effectively cancel the warranty.



PRODUCT OVERVIEW

The **BELLA** line of fixtures and emergency lighting units are highly versatile, slim in design and easy to install with the beghelli patented “plug-in” connection. The injection-molded housing is both corrosion and vandal resistant. The fluorescent light source provides exceptional light output. Custom signage is also available.

INSTALLATION

The **BELLA** luminaire is suitable for surface ceiling or wall mounting, using the included installation bracket. Suitable for indoor installation on normally inflammable surfaces.

EXTERNAL SPECIFICATIONS

The **BELLA** line is constructed of a corrosion, flame and vandal resistant polycarbonate housing. The UV stabilized polycarbonate lens ensures durability and superior light output. The beghelli patented “plug-in” connection makes for the easiest installation in the market.

INTERNAL SPECIFICATIONS

BELLA features a dedicated input (120v) or (277v) transformer, brown-out and short circuit protection and a fully automatic re-charge circuit that is regulated by an electronic voltage sensor. Standard 6v 7ah sealed lead calcium battery provides a minimum 120 minutes emergency duration. The integral reflector is made of self-extinguishing, UV stabilized polycarbonate. Operating temperature is 50°C .

ORDERING INFORMATION

Series	Operation	Input Voltage	Options
8320	HT (AC only)	US (120V)	SW (Special wording)
	SE (Emergency only)	US (277V)	
	SA (AC & Emergency)		

BELLA BUILDER

Series	Operation	Input Voltage	Options

EXAMPLE: 8320-SE-US
 DESCRIPTION: Bella emergency luminaire, emergency only, 120V

JOB:	TYPE:
-------------	--------------

“PLUG IN” MOUNTING

The patented “Plug-In” mounting bracket is wired and connected to a standard junction box with the included adapter plate. The BELLA unit is then snapped and locked onto the mounting bracket. When properly snapped into position, the plug (located on the unit) and the socket (located on the mounting bracket) make a complete connection. With the “Plug-In” connection system the mounting bracket can be installed prior to the BELLA unit itself. This allows for all construction finish work to be completed without any paint or physical damage to the unit. The mounting bracket also allows the BELLA unit to be easily detached and disconnected from the electrical circuit without having to unwire the unit.

BATTERY & CIRCUIT TECHNOLOGY

The BELLA SE and SA models are supplied with a 6V 7Ah maintenance free, sealed lead acid battery for emergency operation. The minimum emergency duration is 120 minutes. Emergency luminous efficiency is 50%. Recharge time of the battery is twenty-four (24) hours. The maximum battery operating temperature is 50° C.

HOUSING

The BELLA is constructed from a corrosion, flame and vandal resistant polycarbonate. The bracket connection allows installation to a standard wall mounted junction box. The plastic injected housing and lens are built for durability and superior function. The slim design allows for simplified, non-intrusive installations.

LAMP & LENS TECHNOLOGY

The BELLA is supplied standard with one (1) 22 watt circline fluorescent lamp, providing 1250 lumens and having an expected lamp life of 16,000 hours. The BELLA lens is a translucent, UV stabilized lens which facilitates consistent fixture performance. The lens completely encloses and protects the lamp from tampering. Custom & special wording is available.

Examples of several custom lenses:

- X-Ray in Use
- Restroom Symbols
- Classroom Numbers
- On the Air
- Directional Arrows
- Library Sections

For further custom signage please consult the factory.

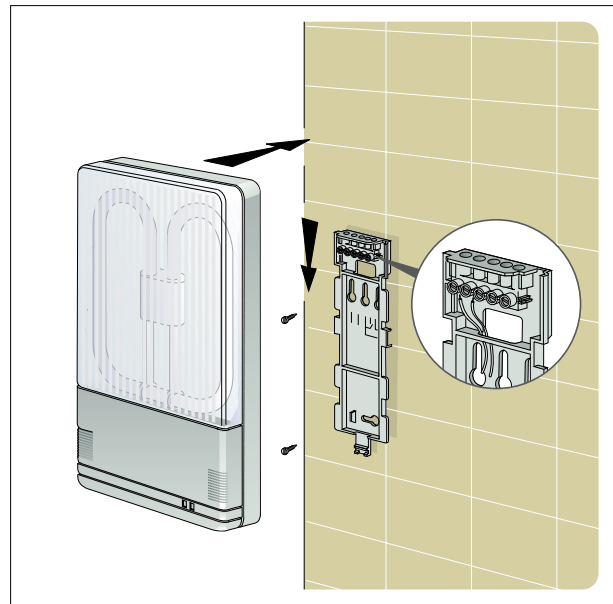

DIMENSIONS (in.)

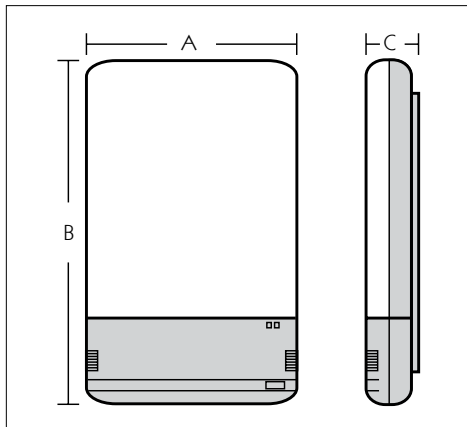

Wattage	A"	B"	C"
	9"	13"	2"

BELLA PHOTOMETRICS

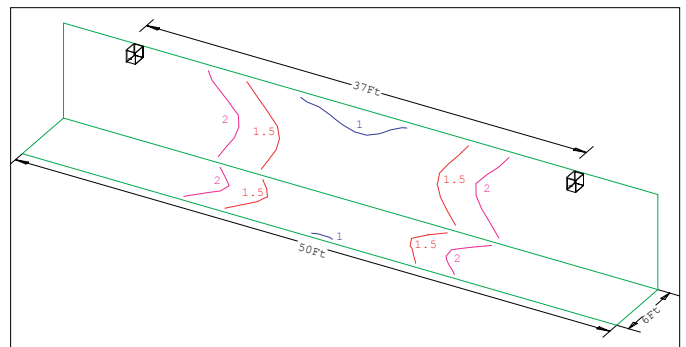

Mounting Height: 8Ft.
Room dimensions: 50Ft (L) x 6Ft (W) x 8Ft (H)
Fixture Spacing: 37Ft.
Avg. Fc.: 2.35

WARRANTY

The BELLA Series comes with a 5-year factory warranty. Lamps are not covered under the warranty. Deliberate damage, misuse, improper installation effectively cancel the warranty.



EXTERNAL SPECIFICATIONS

The **DECO** series is constructed from high quality corrosion and flame resistant thermoplastic. White finish is standard (black color optional). Emergency lighting heads are fixed with prismatic lenses for increased light distribution. Universal mounting bracket is easily snapped onto the **DECO** housing. External test switch and monitor LED are standard.

HOUSING

The **DECO** series utilizes a corrosion and flame resistant injection molded thermoplastic housing and mounting bracket. Lightweight and durable, the **DECO** is ideal for use in areas where materials such as steel and aluminum may deteriorate. The bracket connection allows installation to a standard surface mounted junction box.

INSTALLATION

The **DECO** luminaire is suitable for surface wall or ceiling mounting. Suitable for indoor/damp installation. 120/277VAC.

PRODUCT OVERVIEW

The **DECO** series 2-headed emergency unit has been developed to be architecturally appealing, easy to install, and an economical solution to emergency lighting requirements. The injection molded thermoplastic housing is corrosion and flame resistant. The universal mounting plate allows for effortless installation. The **DECO** comes complete with 2 fixed 5.4W heads. Damp location rating is standard.

ORDERING INFORMATION

Series	Model	Options
DECO	6	B (black housing)

DECO BUILDER

Series	Model	Options

EXAMPLE: DECO-6
 DESCRIPTION: DECO emergency luminaire, emergency only, 6V 11W, damp location

JOB:	TYPE:
-------------	--------------

BATTERY

The DECO series emergency lighting fixture is configured for standard operation 120/277VAC dual voltage input with current limit protection. Current charge regulator is standard. Minimum 90 minutes emergency duration.

LAMPS

The DECO series is supplied with two (2) front mounted, fixed 5.4W wedge base incandescent lamps. The polycarbonate prismatic lenses offer durability and high light distribution.

BATTERY & CIRCUIT TECHNOLOGY

The DECO series is supplied with a maintenance free, sealed lead calcium battery for emergency operation that provides a minimum emergency duration of 90 minutes. The recharge time of the battery is twenty-four (24) hours. The maximum working temperature is 50°C.

HOUSING

The DECO series emergency lighting fixture comes standard rated for damp location installations. The DECO is an ideal solution for exterior covered breezeways, warehouses, covered corridors and retail.

UNIVERSAL MOUNTING

The DECO emergency lighting unit uses a universal mounting bracket that snaps into the DECO housing. Easy field wiring and durability make the DECO a favorite among contractors.

DIMENSIONS (in.)

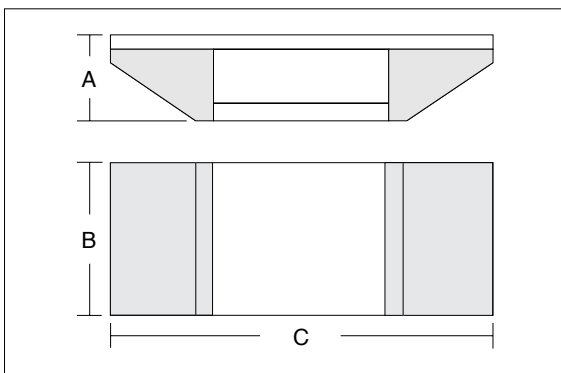

Wattage	A"	B"	C"
2x5.4W"	2 1/4"	5 1/8"	11 7/8"

WARRANTY

The DECO Series comes with a 5-year factory warranty. Lamps are not covered under the warranty. Deliberate damage, misuse, improper installation effectively cancel the warranty.



PRODUCT OVERVIEW

The **BBY** series 2-headed MR16 emergency unit is a high performance affordable thermoplastic emergency luminaire. The injection molded thermoplastic housing is corrosion and flame resistant and features an innovative snap together design allowing fast and easy installation. The standard 5W halogen MR16 lamps are fully adjustable. The **BBY** series comes standard finished in white.

EXTERNAL SPECIFICATIONS

The **BBY** series is constructed from high quality corrosion and flame resistant thermoplastic. White finish is standard. The semi-recessed MR16 emergency lighting heads are molded from the same high quality thermoplastic and positioned in a gimbal style assembly. MR16 lamps are protected by a durable front protective cover. Universal mounting bracket for wall or ceiling installations. External test switch and monitor LED are standard.

INTERNAL SPECIFICATIONS

The **BBY** series is configured with universal 120/277 VAC input with solid state charging circuitry. Standard features include low voltage disconnect, AC lockout and brownout protection.

INSTALLATION

The **BBY** series luminaire is suitable for surface wall or ceiling mounting. Suitable for indoor/damp installations on normally inflammable surfaces. 120/277VAC.

ORDERING INFORMATION

Series	Model
BBY	25MR (6v 10w)

BBY BUILDER

Series	Model

EXAMPLE: BBY-25MR
 DESCRIPTION: BBY emergency luminaire, emergency only, 6V 10W MR-16, white housing.

JOB:	TYPE:
-------------	--------------

HOUSING

The **BBY** series utilizes a corrosion and flame resistant injection molded thermoplastic housing and mounting bracket. The innovative snap together design allows fast and effortless installation. The **BBY** series is ideal for use in areas where materials such as steel and aluminum may deteriorate. The universal mounting pattern allows wall or ceiling installations.

BATTERY

The **BBY** series is supplied with a sealed, maintenance-free, valve regulated 6V 4.5Ah lead calcium battery that provides a minimum emergency duration of 90 minutes. Recharge time of the battery is twenty-four (24) hours. The maximum working temperature is 50° C

EMERGENCY SPECIFICATIONS

The **BBY** series emergency luminaire is configured for standard operation 120/277VAC dual voltage input with current limit protection. Current charge regulator is standard. Minimum 90 minutes emergency duration. 24 hour charge time.

LAMP HEAD FEATURES

The **BBY** series is supplied with two Gimbal style, front mounted 5W MR16 lamps. Lamp heads are constructed of high impact thermoplastic in a color matching the finish of the housing (white is standard).

MR-16 TECHNOLOGY

The **BBY** series emergency luminaire benefits from the use of MR-16 lamp technology. Offering superior light output, compact design, high efficiency and architectural appeal, the MR16 lamps are an intelligent light choice. The **BBY** series comes standard with 2x5W halogen MR16 lamps.

DESIGN FEATURES

The **BBY** series emergency luminaire features an innovative snap together design, easy field wiring & durable construction. All factors making the **BBY** series a contractors favorite.

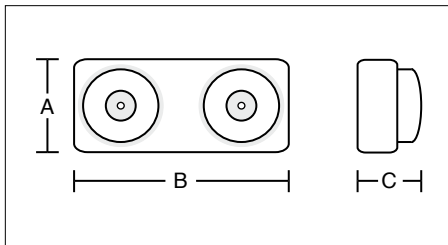
DIMENSIONS (in.)

Wattage	A"	B"	C"
2x5W	5.5"	12.2"	4.2"

WARRANTY

The **BBY** Series comes with a 5-year factory warranty. Lamps are not covered under the warranty. Deliberate damage, misuse, improper installation effectively cancel the warranty



PRODUCT OVERVIEW

The XLP series emergency units have become an industry standard. The architecturally appealing design, ease of installation and economical price are all contributing factors. The injection molded thermoplastic housing is corrosion and flame resistant. The universal mounting plate allows for effortless installation. The standard 5.4W incandescent lamps can be positioned as needed. Damp location rating is standard.

EXTERNAL SPECIFICATIONS

The XLP series is constructed from high quality corrosion and flame resistant thermoplastic. White finish is standard (black color optional). Emergency lighting heads are molded from high impact thermoplastic in a matching color and positioned on a ratcheted track for accurate positioning. Lens material is a high-impact polystyrene. Universal mounting bracket is easily snapped onto the XLP housing. External test switch and monitor LED are standard.

INTERNAL SPECIFICATIONS

The XLP series is configured with universal 120/277 VAC input with solid state charging circuitry. Standard features include low voltage disconnect, AC lockout and brownout protection.

INSTALLATIONS

The XLP luminaire is suitable for surface wall or ceiling mounting. Suitable for indoor / damp installation. 120/277VAC.

ORDERING INFORMATION

Series	Model	Options
XLP	S1 (6V 12W)	B (black housing)
	S2 (6V 18W)	7b (7w lamp / S2 only)
		9b (9w lamp / S2 only)

XLP BUILDER

Series	Lamps	Options

EXAMPLE: XLP-S2-BLK
 DESCRIPTION: XLP emergency luminaire, emergency only, 6V 18W, damp location, black housing.

JOB:	TYPE:
-------------	--------------

BATTERY

The XLP series emergency luminaire is configured for standard operation 120/277VAC dual voltage input with current limit protection. Current charge regulator is standard. Minimum 90 minutes emergency duration. 24 hour charge time.

BATTERY & CIRCUIT TECHNOLOGY

The XLP series is supplied with a maintenance free, sealed valve regulated lead acid battery for emergency operation that provides a minimum emergency duration of 90 minutes (for the listed rating). The S1 model comes standard with a 6V 4.5Ah battery. The S2 model comes standard with a 6V 7Ah battery for remote capability. Recharge time of the battery is twenty-four (24) hours. The maximum working temperature is 50° C.

HOUSING

The XLP series utilizes a corrosion and flame resistant injection molded thermoplastic housing and mounting bracket. Lightweight and durable, the XLP is ideal for use in areas where materials such as steel and aluminum may deteriorate. The bracket connection allows installation to a standard wall mounted junction box.

The XLP series emergency luminaires come standard rated for damp location installations. The XLP is an ideal solution for exterior covered breezeways, warehouses, covered corridors and retail.

LAMP HEAD FEATURES

The XLP series is normally supplied with two (2) front mounted square heads with 5.4W wedge base incandescent lamps. Lamp heads are mounted within a ratcheted track that allows correct and accurate beam positioning. Lamp heads are constructed of high impact thermoplastic in a color matching the finish of the housing (white is standard). Lens material is a high-impact polystyrene.

UNIVERSAL MOUNTING

The XLP emergency lighting unit uses a universal mounting bracket that snaps into the XLP housing. Easy field wiring and durability make the XLP a favorite among contractors.

DIMENSIONS (in.)

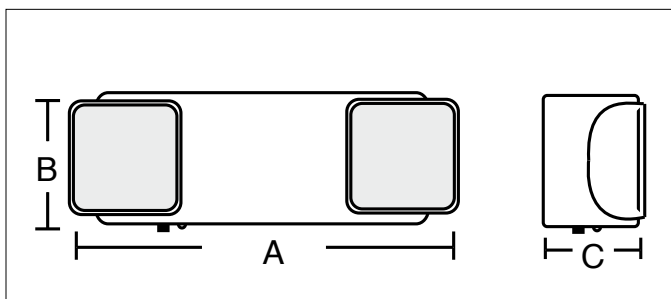

Wattage	A"	B"	C"
2x5W.4 (S1)	11.7"	4.2"	5"
2x5W.4 (S2)	12"	4.2"	5"

WARRANTY

The XLP Series comes with a 5-year factory warranty. Lamps are not covered under the warranty. Deliberate damage, misuse, improper installation effectively cancel the warranty.



EXTERNAL SPECIFICATIONS

The XLP-S3 series is constructed from durable corrosion and flame resistant thermoplastic. Emergency lighting heads are molded from high-impact thermoplastic in a color that matches the housing. The lens material is a high-impact polystyrene. Universal mounting bracket is easily snapped onto the XLP-S3 housing. External test switch and monitor LED are standard.

INTERNAL SPECIFICATIONS

Standard 120/277VAC input, 6V 7Ah sealed lead calcium battery provides minimum 90 minutes emergency duration.

AutotesT: integrated diagnostics that monitor and indicate battery disconnect, charger failure, lamp failure & transformer fault.

The XLP-S3 series is suitable for surface wall or ceiling mounting. Suitable for indoor & damp location installations on normally inflammable surfaces.

INSTALLATIONS

The XLP-S3 series uses an integrated universal mounting bracket that securely snaps into the back of the XLP-S3 housing. Supplied with all the required standard mounting hardware and easy field wiring, the XLP-S3 series is a favorite among installers.

PRODUCT OVERVIEW

The XLP-S3 series is an innovative, yet economical thermoplastic emergency luminaire that includes the Beghelli AutotesT diagnostic circuit as standard equipment. The XLP-S3 allows for instant visual verification of the operating status. Configured to run up to a 6W remote load, the XLP-S3 comes standard with a 6V 7Ah battery. The simple, non-intrusive design, damp location rating and easy installation make the XLP-S3 ideal for commercial, institutional & public projects.

ORDERING INFORMATION

Series	Model	Diagnostics	Options
XLP	S3 (6V 18W)	AT (autotest)	7L (7.2W lamps)
		Note: the Autotest diagnostic feature is standard	9L (9W lamps)
			B (black housing)
			IRT (infrared remote test)
			Note: IRT option includes handheld remote.

XLP-S3 BUILDER

Series	Model	Diagnostics	Options

EXAMPLE: XLP-S3-AT-7L

DESCRIPTION: XLP emergency luminaire, 2x8W halogen, damp location 120/277V

JOB:	TYPE:
-------------	--------------

AUTOTEST DIAGNOSTICS

The **XLP-S3** series comes standard with the Beghelli Autotest diagnostic system. Featuring continuous monitoring of the units main components (battery, charger, transformer and lamps) and providing instant visual verification of the status.

AUTOTEST FEATURES

Monitors battery disconnection, charger failure, lamp failure and transformer fault every 5 seconds without discharging the battery. Automatically indicates lamp, battery and charger status by dual-color LED lamp. Factory preset Autotest does not need to be field adjusted reset for proper operation. Verifies battery disconnect, charger board failure, lamp failure and transformer failure every 5 seconds.

- One (1) minute autotest every month.
- Thirty (30) minute autotest every six (6) months.
- Ninety (90) minute autotest every twelve (12) months.

AUTOTEST FUNCTIONS

Verifies battery disconnect, charger board failure, lamp failure and transformer failure every 5 seconds.
 One (1) minute autotest every month.
 Thirty (30) minute autotest every six (6) months.
 Ninety (90) minute autotest every twelve (12) months.

AUTOTEST VISUAL ALERTS

- (1) blink red LED = Battery not connected
- (2) blinks red LED = Battery shorted and/or Battery voltage drop
- (3) blinks red LED = Charger board fault
- (4) blinks red LED = Transformer fault
- (5) blinks red LED = Emergency lamp fault
- (6) blinks red LED = Remote lamp fault

AUTOTEST MANUAL FUNCTIONS

- Press test button 1x (within 2 sec.) = 1 minute test
- Press test button 2x (within 2 sec.) = 5 minute test
- Press test button 3x (within 2 sec.) = 30 minute test
- Press test button 4x (within 2 sec.) = 90 minute test

HOUSING

The **XLP-S3** series is constructed from corrosion and flame resistant thermoplastic. Lightweight and durable, the **XLP-S3** is an easy to install solution in areas where materials such as steel and aluminum may deteriorate. The **XLP-S3** mounting bracket can be connected to a standard junction box.

BATTERY

The **XLP-S3** series features a maintenance-free sealed lead calcium battery (6V 7Ah) that provides the **XLP-S3** with a minimum emergency operating time of 90 minutes. The **XLP-S3** is configured to operate one (1) remote location emergency head with a maximum 6W lamp load. Recharge time for the battery is 24 hours. The maximum operating temperature is 50°C.

LAMP HEAD FEATURES

The **XLP-S3** series uses two (2) front mounted square heads with 5.4W wedge base incandescent lamps. Optional 7.2w or 9w wedge base lamps are available. The lamp heads are securely mounted within a track that provides easy rotation and adjustment, ensuring proper beam positioning. Lamp heads are constructed from high-impact thermoplastic. The lens material is a high-impact polystyrene.

SUITABLE FOR DAMP LOCATIONS

The **XLP-S3** series is rated for use in damp locations. The **XLP-S3** is ideal for use in exterior covered breezeways, warehouses, covered corridors, pool areas and retail.

DIMENSIONS (in.)

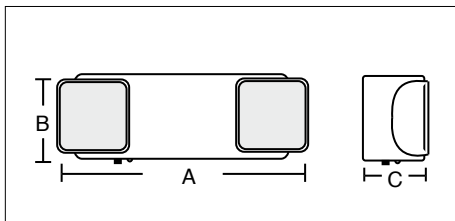

Wattage	A"	B"	C"
2x5W.4 (S1)	11.7"	4.2"	5"

WARRANTY

The **XLP-S3** Series comes with a 5-year factory warranty. Lamps are not covered under the warranty. Deliberate damage, misuse, improper installation effectively cancel the warranty.



PRODUCT OVERVIEW

The Ecco Luna is an architecturally designed emergency luminaire that performs. Italian design, high performance optics, durable polycarbonate construction, fully enclosed lamp heads, easy installation and a competitive price make the Ecco-Luna a favorite among contractors, distributors and specifiers. The vandal and impact resistant polycarbonate housing completely encloses the reflector and fully adjustable 8W lamp assemblies. Damp location option included.

EXTERNAL SPECIFICATIONS

The Ecco LUNA series housing is constructed from high quality corrosion, flame and vandal resistant polycarbonate. The highly efficient lens completely encloses and protects the units lamp assemblies. Vandal resistant latch clips ensure the integrity of the Ecco LUNA emergency lighting unit.

INTERNAL SPECIFICATIONS

The Ecco LUNA series is configured with universal 120/277 VAC input with solid state charging circuitry. Standard features include low voltage disconnect, AC lockout and brownout protection.

INSTALLATION

The Ecco LUNA emergency luminaire is suitable for surface wall or ceiling mounting. Suitable for indoor / damp installation. 120/277VAC

ORDERING INFORMATION

Series	Lamps	Operations	Input Voltage	Options
EL	28 (2x8W halogen)	SE (emergency only)	UNV (120/277V)	DL (damp locations)
				10L (10w halogen)
				12L (12w halogen)

ECCO LUNA BUILDER

Series	Lamps	Operation	Input Voltage	Options

EXAMPLE: EL-28SE-UNV-DL
 DESCRIPTION: EL emergency luminaire, 2x8W halogen, damp location 120/277V

JOB:	TYPE:
-------------	--------------

The **Ecco LUNA** series emergency luminaire is configured for standard operation 120/277VAC dual voltage input with current limit protection. Current charge regulator is standard. Minimum 90 minutes emergency duration. 24 hour charge time.

BATTERY & CIRCUIT TECHNOLOGY

The **Ecco LUNA** series emergency unit uses an two 6 volt 5AH sealed lead acid batteries that provides a minimum 90 minutes emergency duration. The automatic recharge circuit is regulated by an electronic volt sensor and the battery is protected by a low-voltage cut-off circuit. 120/277VAC dual voltage input. The maximum operating temperature is 50° C.

VANDAL RESISTANT DESIGN

The **Ecco LUNA** lens reflector cover has been designed to fully enclose the lamp assemblies. This protects the lamp heads from tampering and unwanted repositioning.

REFLECTOR

The **Ecco LUNA** reflector is made of injection molded, self-extinguishing, UV stabilized polycarbonate. The reflector supports components including the lamp assemblies and circuit.

HOUSING

The **Ecco LUNA** series emergency luminaire is available with a standard damp location label. The **Ecco LUNA** with the damp option is an ideal solution for exterior covered breezeways, warehouses, covered corridors and high humidity regions.

HIGH-OUTPUT DESIGN

The **Ecco LUNA** incorporates an efficient and high-output lens. The diffusion lens has been designed to effectively transmit the greatest amount of luminaires with the least transmittal loss.

DIFFUSER

The **Ecco LUNA** diffuser is UV stabilized to reduce the yellowing index and provide superior light output.

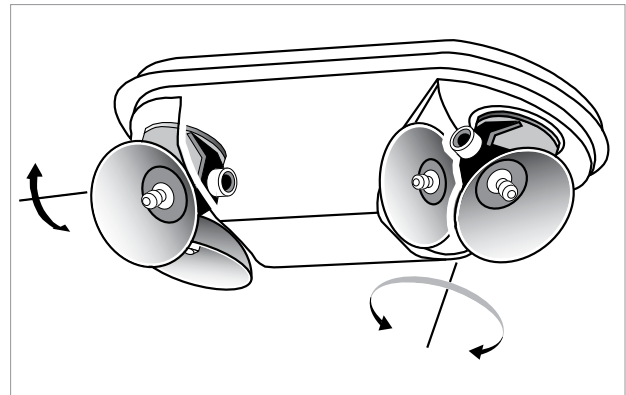

DIMENSIONS (in.)

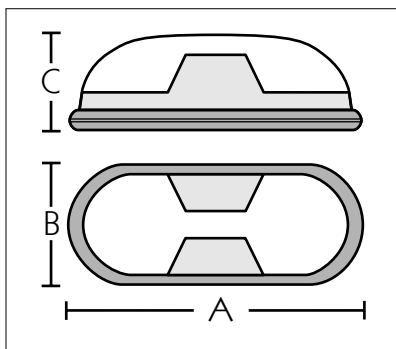

Wattage	A"	B"	C"
2x8W	17"	6 1/2"	4"

WARRANTY

The **Ecco LUNA** Series comes with a 5-year factory warranty. Lamps are not covered under the warranty. Deliberate damage, misuse, improper installation effectively cancel the warranty.

MECHANICAL SPECIFICATIONS

The **RSE** is constructed with a solid and durable 20 gauge steel housing. Torsion springs firmly hold the **RSE** cover in place allowing for easy installation and maintenance. Remote lamp loads are connected to the emergency power supply with sturdy magnum terminal connectors. These connectors allow for a large gauge of wire to be used, increasing the flexibility of installation. The **RSE** is supplied standard in a durable white powder coat, baked finish. Other colors are available, including custom color matching, please specify.

CHARGER SPECIFICATIONS

The **RSE** series utilizes a pulse switching charger that is up to 70% more efficient than older constant voltage chargers. The charger is a fully automatic current limited charger with solid state line-latched low voltage disconnect protection. All components used in the circuitry are temperature compensated. The charger also has brownout and short circuit protection. Charger status is easily determined via a dual diagnostic LED display which indicates AC/ON and High Charge. An external push button test switch allows maintenance personnel to quickly determine the operational status of the unit and lamp load. 120/277VAC dual voltage input.

BATTERY TECHNOLOGY

The **RSE** series is designed with a maintenance free, sealed valve regulated lead acid battery that provides a minimum emergency duration of 90 minutes (for the listed rating). Recharge time of the battery is twenty-four (24) hours. The maximum working temperature is 50° C.

RECESSED DESIGN

The **RSE** series emergency unit is designed to be fully recessed into a drop ceiling, standard ceiling or wall. Torsion springs securely hold the **RSE** cover in place. The fully recessed design make the **RSE** ideal for running remote loads and maintaining an architectural element.

BEGHELLI AUTO-TEST

The **RSE** auto-test feature automatically monitors the functional operation of the unit. Auto-test monitors the operation of the lamps, battery and circuitry and displays any alerts. Periodic emergency tests, up to ninety (90) minutes duration are simulated to ensure proper operation during an actual power failure. Operating status is visually indicated by multi-function LED indication.

MODEL RATING GUIDE

Model	Voltage	Wattage			
		90min	120min	180min	240min
RSE-6-18	6	18	12	N/A	N/A
RSE-6-27	6	27	20	N/A	N/A
RSE-6-36	6	36	24	18	12
RSE-12-36	12	36	24	18	12

LAMP HEAD FEATURES

The **RSE** series is normally supplied with two (2) LR Par36 style 9w heads. SR Par18 style heads are optional. Both lamp head styles are constructed of high impact thermoplastic in a color matching the finish of the cabinet (white is standard). Both head types feature a unique twist locking collar that securely holds the lens and facilitates quick and easy re-lamping.

DIMENSIONS (in.)

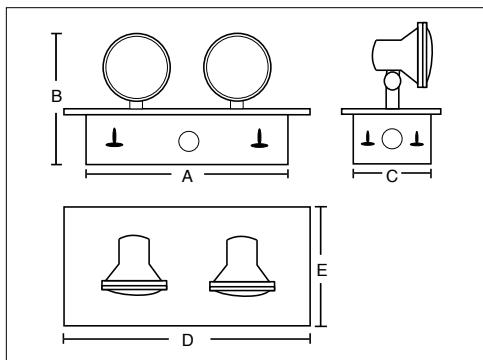

Wattage	A"	B"	C"	D"	E"
18W-36W	10.2"	9.5"	8.1"	13"	9.2"

WARRANTY

The **RSE** Series comes with a 5-year factory warranty. Lamps are not covered under the warranty. Deliberate damage, misuse, improper installation effectively cancel the warranty.

MOUNTING SPECIFICATIONS

The **RTB** is designed to be installed into T-bar type grid ceiling systems. This type of mounting provides a clean and architecturally conscious installation since the cabinet and all wiring connections can be hidden above the ceiling. Once installed, all that remains visible is the attractive front plate and unit lamp heads. The **RTB** has a T-bar mounting bracket located on each side of the unit that aligns the unit onto the T-bar grid. Various chain holes can also be accessed to chain mount the unit to secure points above the ceiling line.

MECHANICAL SPECIFICATIONS

The **RTB** is constructed with a solid and durable 20 gauge steel housing. Stamped conduit knockouts are provided on the sides of all **RTB** units. Remote lamp loads are connected to the emergency power supply with sturdy magnum terminal connectors. These connectors allow for a large gauge of wire to be used, increasing the flexibility of installation. The **RTB** is supplied standard in a durable white powder coat, baked finish. Other colors are available, including color matching, please specify.

CHARGER SPECIFICATIONS

The **RTB** series utilizes a pulse switching charger that is up to 70% more efficient than older constant voltage chargers. The charger is a fully automatic current limited charger with solid state line-latched low voltage disconnect protection. All components used in the circuitry are temperature compensated. The charger also has brownout and short circuit protection. Charger status is easily determined via a dual diagnostic LED display which indicates AC/ON and High Charge. An external push button test switch allows maintenance personnel to quickly determine the operational status of the unit and lamp load.

DIMENSIONS (in.)

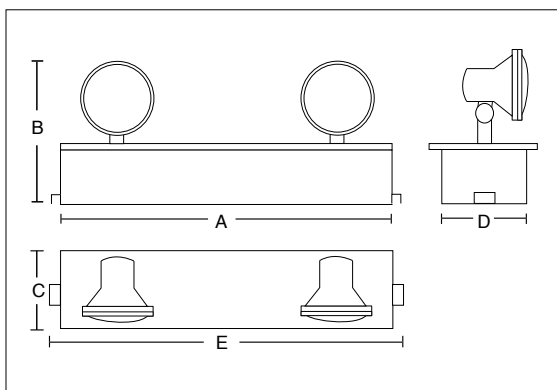

Wattage	A"	B"	C	D	E
27W-100W	24"	4"	5"	3.25"	25.75"

BATTERY TECHNOLOGY

The **RTB** series is designed with a maintenance free, sealed valve regulated lead acid battery that provides a minimum emergency duration of 90 minutes (for the listed rating). Recharge time of the battery is twenty-four (24) hours. The maximum working temperature is 50° C.

MODEL RATING GUIDE

Model	Voltage	Wattage			
		90min	120min	180min	240min
RTB-6-27	6	27	20	14	10
RTB-6-36	6	36	24	18	12
RTB-6-54	6	54	40	34	20
RTB-12-36	12	36	24	18	12
RTB-12-54	12	54	40	34	20
RTB-12-100	12	100	75	50	40

LAMP HEAD FEATURES

The **RTB** series is typically supplied with two (2) LR Par36 style 9w heads. SR Par18 heads are also available. Both head styles are constructed of high impact thermoplastic in a color matching the finish of the cabinet (white is standard). Both feature a unique twist locking collar that securely holds the lens and facilitates quick and easy re-lamping.

BEGHELLI AUTO-TEST

The **RTB** auto-test feature automatically monitors the functional operation of the unit. Auto-test monitors the operation of the lamps, battery and circuitry and displays any alerts. Periodic emergency tests, up to ninety (90) minutes duration are simulated to ensure proper operation during an actual power failure. Operating status is visually indicated by multi-function LED indication.

WARRANTY

The **RTB** Series comes with a 5-year factory warranty. Lamps are not covered under the warranty. Deliberate damage, misuse, improper installation effectively cancel the warranty.



INTERNAL SPECIFICATIONS

The RDO series is configured with universal 120/277 VAC input with solid state charging circuitry. Standard features include low voltage disconnect, AC lockout and brownout protection.

EXTERNAL SPECIFICATIONS

The RDO series is constructed from durable and lightweight aluminum. The standard trim plate is finished in white powder coat. External test switch and monitor LED are standard

INSTALLATIONS

The RDO emergency luminaire is suitable for ceiling recess installations. Suitable for indoor location installations. 120/277VAC.

PRODUCT OVERVIEW

The RDO series emergency luminaire has been designed to be fully recessed and blend in with the surrounding environment. The housing and gimbal assembly use corrosion and flame resistant lightweight aluminum. All RDO electronics are fully self-contained within the housing; this allows for easy handling and effortless installation. The standard trim plate comes finished in white powder coat.

ORDERING INFORMATION

Series	Operation	Lamps
RDO	SE (emergency only)	8W (halogen)
	RC (remote only)	

RDO BUILDER

Series	Operation	Lamps

EXAMPLE: RDO-SE-8W
 DESCRIPTION: RDO emergency luminaire, emergency only, 120/277V, 8W halogen, recess mount.

JOB:	TYPE:
-------------	--------------

MECHANICAL SPECIFICATIONS

The RDO is constructed with corrosion and flame resistant light-weight aluminum. The gimbal assembly allows for proper beam positioning. All electronics are fully self-contained allowing easy handling and installation. The RDO comes standard with a single 8W halogen lamp. The trim plate is finished in durable powder coat white. External test switch and monitor LED are standard.

LAMP HEAD FEATURES

The RDO series is supplied with one (1) 8 watt bi-pin halogen lamp. The fully recessed design of the RDO uses an adjustable gimbal for correct and accurate beam positioning.

BATTERY TECHNOLOGY

The RDO series is designed with a 6V 4.5Ah maintenance free, sealed valve regulated lead acid battery that provides a minimum emergency duration of 90 minutes (for the listed rating). Re-charge time of the battery is twenty-four (24) hours. The maximum working temperature is 50° C.

CHARGER SPECIFICATIONS

The RDO series utilizes a pulse switching charger that is up to 70% more efficient than older constant voltage chargers. The charger is a fully automatic current limited charger with solid state line-latched low voltage disconnect protection. All components used in the circuitry are temperature compensated. The charger also has brownout and short circuit protection. Charger status is easily determined via a dual diagnostic LED display which indicates AC/ON and High Charge. An external push button test switch allows maintenance personnel to quickly determine the operational status of the unit and lamp load.

DIMENSIONS (in.)

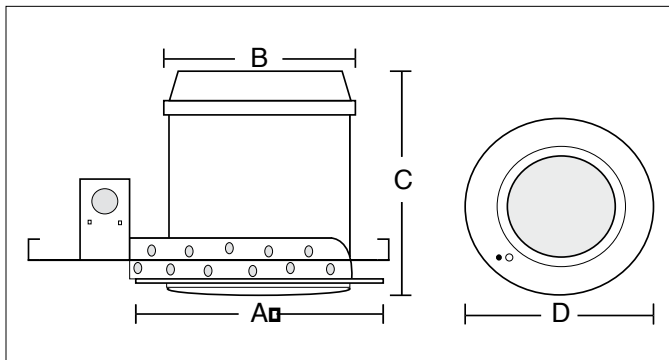

Wattage	A"	B"	C"	D"
8W	9"	6.7"	7.2"	9"

WARRANTY

The RDO Series comes with a 5-year factory warranty. Lamps are not covered under the warranty. Deliberate damage, misuse, improper installation effectively cancel the warranty.

Architectural Emergency

Wet Location

SECTION TWO



CONTENTS



Luna Series

Halogen lamp: 5W Page

Ceiling & wall installed product specifications. Wet Location/IP65. 36

Technical Data 37



Luna XLR Series

Halogen lamp: 5W-12W Page

Ceiling & wall installed product specifications. Wet Location/IP65. 38

Technical Data 39



Tempesta Series

Compact Fluorescent lamp 24W Page

Ceiling & wall installed product specifications. Wet Location/IP65. 40

Technical Data 41



Gran Luce Series

Linear Fluorescent 2x24W Page

Ceiling & wall installed product specifications. Wet Location/IP65. 42

Technical Data 43



Stormguard Series

Compact Fluorescent lamp 24W

Ceiling & wall installed product specifications. Wet Location/IP65. 44

Technical Data 45



PRODUCT OVERVIEW

The LUNA series offers the ultimate in Italian design and technology. Legendary durability, reliability and performance best describe the LUNA. The fully gasketed housing encloses the high output metalized reflector and lamp head assemblies. Beghelli AUTOTEST diagnostics comes standard. The optional patented Path Marking System safely and effectively designates the path of egress in a smoke filled environment.

DIFFUSER

The LUNA diffuser is UV stabilized to reduce the yellowing index and provide superior light output. The co-injection process increases the strength and durability of the LUNA diffuser.

INSTALLATION

Surface ceiling or wall mounting. Suitable for wet location installations.

REFLECTOR

The LUNA reflector is made of injection molded, self-extinguishing, UV stabilized polycarbonate. Vacuum metalization results in a highly reflective surface. The reflector supports components including the lamp holder and circuit.

EXTERNAL SPECIFICATIONS

The LUNA series housing is constructed from high quality corrosion, flame and vandal resistant polycarbonate. The highly efficient lens completely encloses and protects the units lamp assemblies. Liquid silicon gasketing is "hot-bonded" to the housing during the manufacturing process, ensuring its durability and effectiveness. Vandal resistant latch clips ensure the integrity of the LUNA emergency lighting unit.

INTERNAL SPECIFICATIONS

The LUNA series uses dedicated 120V or 277V AC. Input the automatic recharge circuit is regulated by an electronic voltage sensor and the battery is protected by a low voltage cut-off circuit.

CUSTOM COLORS

The LUNA series can be ordered in optional (CC) custom color finishes.



ORDERING INFORMATION

Series	Lamps	Operation	Input Voltage	Auto-Test	Options
LA	25 (2x5w halogen)	SE (emergency)	US (120V)	AT (auto-test)	L
			US2 (277V)		CC

LUNA BUILDER

Series	Model	Options	Input Voltage	Auto-Test	Options

EXAMPLE: LA25-SE-US-AT

DESCRIPTION: Luna emergency luminaire, 2x5 watt halogen, 120V, auto-test

*Beghelli Auto-Test comes standard on all LUNA XLR emergency units.

JOB:	TYPE:
-------------	--------------

BATTERY & CIRCUIT TECHNOLOGY

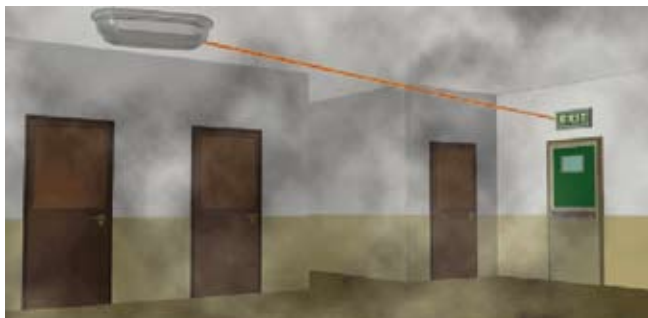

The LUNA series specified with the optional “path marking system” offers an entirely new level of egress safety. The patented “path marking system” clearly marks the exit and the path leading to the exit in smoke filled environments. Laser technology is instantly recognizable as a path marker and is easily followed to safety. The laser can be installed on either side of the LUNA and directed towards the exit. The “path marking system” is ideal for use in environments that make use of steam, dry ice, special effects, pyrotechnics and chemicals. It is also ideal in hospitals, nursing homes, schools, universities, shopping centers, hotels, resorts and theme parks.

AUTO TEST DIAGNOSTIC

The LUNA series is supplied standard with a fully configured auto-test feature that continually monitors the functional operation of the unit. The lamps, battery and circuitry are continually tested to ensure proper operation. A visual display alerts of any malfunctioning component.

- Flashing Red: Emergency Inhibited / Under Change
- Red: Battery or Circuit Malfunction
- Yellow: Lamp Malfunctioning
- Flashing Yellow: Test Active
- Green: Normal Operation

Auto-test is comprised of an 8-bit microprocessor capable of integrating a large number of functions. Auto-test continually monitors the functional operation of the lamps, battery and circuitry.

DIMENSIONS (in.)

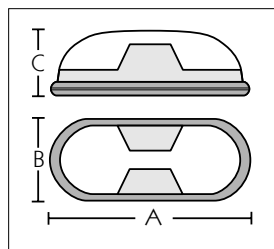

Wattage	A"	B"	C"
2x5W	17"	6 1/2"	4"

Periodic emergency duration tests are internally simulated to ensure proper operation during an actual power failure. The functionality test, which is internally simulated weekly, is used to check all functions of the lamps over a one (1) minute period. The emergency duration test, which is run every six (6) months, is used to check all functions of the lamps and battery over a period of time equal to the emergency duration required under the relevant Code or Standard. Results of the tests are displayed by the tri-color LED located on the front panel of the LUNA where it can be quickly and easily read by maintenance personnel.

IP/WET LOCATION GASKETING

The LUNA carries an IP65 / Wet location rating. Emergency units are especially vulnerable to fire sprinkler activation since emergency lighting units are often installed right next to sprinkler heads. The IP65 / Wet location rating ensures protection not just from ambient moisture but also from jets of water like those given off by broken or activated sprinkler heads.

HIGH OUTPUT DESIGN

The LUNA incorporates an efficient and high-output lens and reflector. Vacuum metalization technology is used in the manufacturing of the reflector, resulting in a high-efficiency, mirror-like reflector. The diffusion lens has been designed to effectively transmit the greatest amount of luminaires with the least amount of transmittal loss.

Lamp assemblies can be rotated, aimed and locked on two (2) axis for the ultimate in adjustability, ease of use and accurate beam positioning.

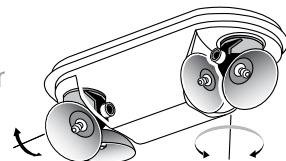

BATTERY & CIRCUIT TECHNOLOGY

The LUNA series emergency unit uses an internal 6 volt 5Ah sealed lead acid battery that provides a minimum 90 minutes emergency duration. The automatic recharge circuit is regulated by an electronic volt sensor and the battery is protected by a low-voltage cut-off circuit. An input voltage of 120V or 277V must be selected when ordering from the factory.

The LUNA Series comes with a 5-year factory warranty. Lamps are not covered under the warranty. Deliberate damage, misuse, improper installation effectively cancel the warranty.

WARRANTY

The LUNA Series comes with a 5-year factory warranty. Lamps are not covered under the warranty. Deliberate damage, misuse, improper installation effectively cancel the warranty.



PRODUCT OVERVIEW

The LUNA XLR has been configured to operate higher output lamps and / or carry a remote load. The Italian designed housing complements any interior, while the polycarbonate construction ensures durability. With the ability to house an additional battery, the LUNA XLR is ideal for running a small remote load. The optional patented Path Marking System safely and effectively designates the path of egress in a smoke filled environment.

DIFFUSER

The LUNA XLR diffuser is UV stabilized to reduce the yellowing index and provide superior light output. The co-injection process increases the strength and durability of the LUNA XLR diffuser.

INSTALLATION

Surface ceiling or wall mounting. Suitable for wet location installations on normally inflammable surfaces.

REFLECTOR

The LUNA XLR reflector is made of injection molded, self-extinguishing, UV stabilized polycarbonate. Vacuum finishing results in a highly reflective surface. The reflector supports components including the lamp holder and circuit.

EXTERNAL SPECIFICATIONS

The LUNA XLR series housing is constructed from high quality corrosion, flame and vandal resistant polycarbonate. The highly efficient lens completely encloses and protects the units lamp assemblies. Liquid silicon gasketing is "hot-bonded" to the housing during the manufacturing process, ensuring its durability and effectiveness. Vandal resistant latch clips ensure the integrity of the LUNA XLR emergency lighting unit.

INTERNAL SPECIFICATIONS

The LUNA XLR series uses dedicated 120V or 277V AC. The automatic recharge circuit is regulated by an electronic voltage sensor and the battery is protected by a low voltage cut-off circuit.

CUSTOM COLORS

The LUNA XLR series can be ordered in optional (CC) custom color finishes.

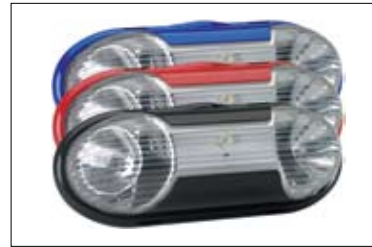

ORDERING INFORMATION

Series	Lamps	Operation	Input Voltage	Auto-Test	Options
LAX	25 (2x5w halogen)	SE (emergency)	US (120V)	*AT (auto-test)	L
			US2 (277V)		CC
					8WH
					10WH
					12WH

LUNA BUILDER

Series	Model	Options	Input Voltage	Auto-Test	Options

EXAMPLE: LAX25-SE-US-AT

DESCRIPTION: Luna emergency luminaire, 2x5 watt halogen, 120V, auto-test

*Beghelli Auto-Test comes standard on all LUNA XLR emergency units.

JOB:	TYPE:
-------------	--------------

BATTERY & CIRCUIT TECHNOLOGY

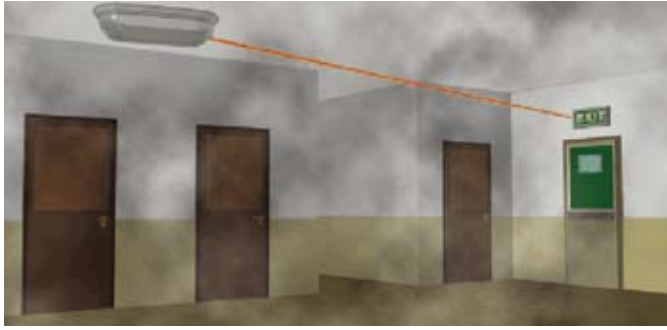

The **LUNA XLR** series specified with the optional “path marking system” offers an entirely new level of egress safety. The patented “path marking system” clearly marks the exit and the path leading to the exit in smoke filled environments. Laser technology is instantly recognizable as a path marker and is easily followed to safety. The laser can be installed on either side of the **LUNA XLR** and directed towards the exit. The “path marking system” is ideal for use in environments that make use of steam, dry ice, special effects, pyrotechnics and chemicals. It is also ideal in hospitals, nursing homes, schools, universities, shopping centers, hotels, resorts and theme parks.

AUTO-TEST DIANOSITICS

The **LUNA XLR** series is supplied standard with a fully configured auto-test feature that continually monitors the functional operation of the unit. The lamps, battery and circuitry are continually tested to ensure proper operation. A visual display alerts of any malfunctioning component.

- Flashing Red: Emergency Inhibited
- Red: Battery or Circuit Malfunction
- Yellow: Lamp Malfunctioning
- Flashing Yellow: Test Inhibited
- Green: Normal Operation

DIMENSIONS (in.)

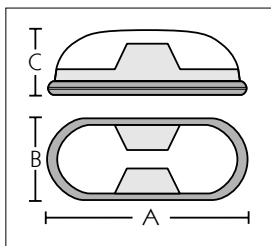

Wattage	A"	B"	C"
2x5W	17"	6 1/2"	4"

Auto-test is comprised of an 8-bit microprocessor capable of integrating a large number of functions. Auto-test continually monitors the functional operation of the lamps, battery and circuitry. Periodic emergency duration tests are internally simulated to ensure proper operation during an actual power failure. Check all functions of the lamps over a one (1) minute period. The emergency duration test, which is run every six (6) months, is used to check all functions of the lamps and battery over a period of time equal to the emergency duration required under the relevant Code or Standard.

Results of the tests are displayed by the multi-color LED located on the front panel of the **LUNA XLR** where it can be quickly and easily read by maintenance personnel.

IP65 / WET LOCATIONS

The **LUNA XLR** carries an IP65 / Wet location rating. Emergency units are especially vulnerable to fire sprinkler activation since emergency lighting units are often installed right next to sprinkler heads. The IP65 / Wet location rating ensures protection not just from ambient moisture but also from jets of water like those given off by broken or activated sprinkler heads.

HIGH OUTPUT DESIGN

The **LUNA XLR** incorporates an efficient and high-output lens and reflector. Vacuum metalization technology is used in the manufacturing of the reflector, resulting in a high-efficiency, mirror-like reflector. The diffusion lens has been designed to effectively transmit the greatest amount of luminaires with the least amount of transmittal loss.

Lamp assemblies can be rotated, aimed and locked on two (2) axis for the ultimate in adjustability, ease of use and accurate beam positioning.

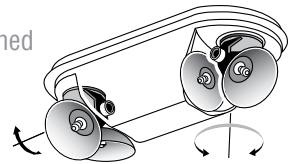

BATTERY & CIRCUIT TECHNOLOGY

The **LUNA XLR** series emergency unit uses two(2) internal 6 volt 5Ah sealed lead acid batteries that provides a minimum 90 minutes emergency duration and remote capability. The automatic recharge circuit is regulated by an electronic volt sensor and the battery is protected by a low-voltage cut-off circuit. An input voltage of 120v or 277v must be selected when ordering from the factory.

WARRANTY

The **LUNA XLR** Series comes with a 5-year factory warranty. Lamps are not covered under the warranty. Deliberate damage, misuse, or improper installation effectively cancel the warranty.



PRODUCT OVERVIEW

The TEMPESTA™ offers Italian design, reliability and increased fixture to fixture performance. The use of fluorescent technology allows for an improved spread of light, fewer units to install and maintain and creates a safer environment during a power failure. The lens is clear by design, allowing the greatest amount of light to be dispersed. Designed for wall or ceiling installations.

REFLECTOR

The TEMPESTA™ reflector is made of injection molded, self-extinguishing, UV stabilized polycarbonate. Vacuum metalization results in a highly reflective surface. The reflector supports components including the lamp holder and reflective hood.

DIFFUSER

The TEMPESTA™ diffuser is UV stabilized to reduce the yellowing index and provide superior light output. The co-injection process increases the strength and durability of the TEMPESTA™ diffuser.

EXTERNAL SPECIFICATIONS

The TEMPESTA™ series housing is constructed from high quality corrosion, flame and vandal resistant polycarbonate. Vandal resistant latch clips ensure the integrity of the TEMPESTA™. Mounting locations for ceiling or wall installations are clearly marked on the housing. The TEMPESTA™ comes finished in a standard grey RAL 7035 color.

INTERNAL SPECIFICATIONS

The TEMPESTA™ series is configured with universal 120/277VAC input. The automatic recharge circuit is regulated by an electronic volt sensor and the standard Ni-Cd battery is protected by a low voltage cut-off circuit.

INSTALLATION

Surface or recess ceiling and wall mounting. Suitable for wet location installations.

BATTERY TECHNOLOGY

The TEMPESTA™ series is offered standard with a 5 cell nickel cadmium battery pack that provides a minimum of 90 minutes emergency duration. An optional Ni-Mh is available.

VANDAL RESISTANT DESIGN

The TEMPESTA™ series diffuser has been designed to fully enclose and protect the lamp assembly. Vandal resistant flush housing latch clips ensure the integrity of the TEMPESTA™ and discourage fixture tampering.

ORDERING INFORMATION

Series	Lamps	Operation	Input Voltage	Auto-Test	Options
TA	24 (1x24w CF fluorescent)	HT (AC only)	UNV (120/277V)	*AT (auto-test)	NM (Ni-Mh batteries)
		SE (emergency only)			RTD (recess trimplate drywall) RTT (recess trimplate t-bar)

TEMPESTA BUILDER

Series	Lamps	Operation	Input Voltage	Auto-Test	Options

EXAMPLE: TA24-SE-UNV-AT
DESCRIPTION: Tempesta emergency luminaire, emergency only, 120/277V, auto-test

*Beghelli Auto-Test comes standard on all TEMPESTA emergency units.

JOB:	TYPE:
-------------	--------------

NICKEL METAL HYDRIDE BATTERIES

An optional power source available for the TEMPESTA™ series are nickel metal hydride (Ni-Mh) batteries. The primary feature of Ni-Mh batteries is their long life. Ni-Mh batteries are capable of 500 to 1000 charge and discharge cycles and the expected life of the battery is higher than the minimum required by the current technical standards (EN60598-2-22). Ni-Mh batteries are not subject to the “memory effect,” a typical drawback of Ni-Cd batteries, that could result in a reduction in the nominal operation. A further feature of the Ni-Mh batteries is their very high efficiency, more than double that of lead and Ni-Cd batteries. Nickel Metal Hydride batteries have a low environmental impact and are disposable.

HIGH OUTPUT DESIGN

The TEMPESTA™ unit incorporates an efficient high output lens and reflector. Vacuum metalization technology is used in the manufacturing of the reflector, resulting in a high transmission mirror-like finish. The diffuser has been designed to effectively transmit the greatest amount of light with the least transmittal loss. A removable reflecting hood allows for directional control of the luminaires, increasing the light output at the floor level; resulting in greater fixture to fixture spacing. This in turn reduces installation, operational and maintenance costs.

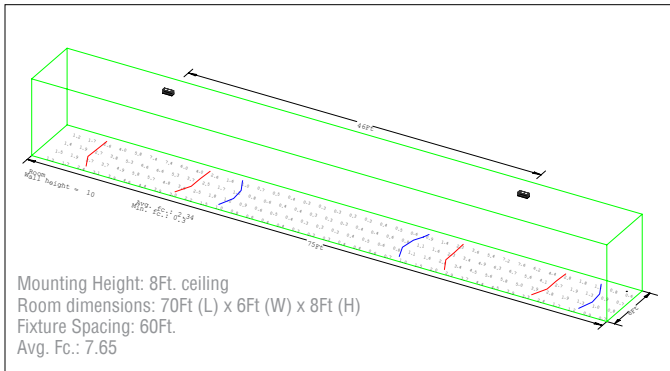

DIMENSIONS (in.)

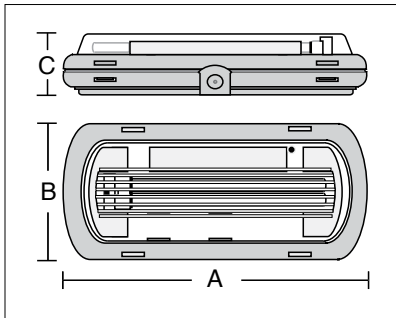

Wattage	A"	B"	C"
1x27W	17"	6 1/2"	3 1/2"

AUTO-TEST DIAGNOSTICS

The TEMPESTA™ is supplied standard with a fully configured auto-test feature that continually monitors the functional operation of the unit. The lamp, battery and circuitry are continually tested to ensure proper operation. A visual display alerts of any malfunctioning component.

- Flashing Red: Emergency Inhibited
- Red: Battery or Circuit Malfunction
- Yellow: Lamp Malfunctioning
- Flashing Yellow: Test Inhibited
- Green: Normal Operation

Beghelli auto-test is comprised of an 8-bit microprocessor capable of integrating a large number of functions. Auto-test continually monitors the functional operation of the lamps, battery and circuitry. Periodic emergency duration tests are internally simulated to ensure proper operation during an actual power failure. The functionality test, which is internally simulated weekly, is used to check all functions of the lamps over a one (1) minute period. The emergency duration test, which is run every six (6) months, is used to check all functions of the lamps and battery over a period of time equal to the emergency duration required under the relevant Code or Standard. Results of the tests are displayed by the multi-color LED located on the front panel of the TEMPESTA™ where it can be quickly and easily read by maintenance personnel.

IP65 / WET LOCATION GASKETING

The TEMPESTA™ carries an IP65 / Wet location rating. Emergency units are especially vulnerable to fire sprinkler activation since emergency lighting units are often installed right next to sprinkler heads. The IP65 / Wet location rating ensures protection not just from ambient moisture but also from jets of water like those given off by broken or activated sprinkler heads

The TEMPESTA™ unit incorporates a 24 watt compact fluorescent lamp with 1350 lumens during DC operation. The Tempesta operates at 75% during emergency operations. This in turn, translates into energy efficiency, increased fixture spacing and lower installation costs..

WARRANTY

The TEMPESTA™ Series comes with a 5-year factory warranty. Lamps are not covered under the warranty. Deliberate damage, misuse, improper installation effectively cancel the warranty.



PRODUCT OVERVIEW

The **GLT** offers flexibility in your lighting design by featuring flexibility in its configuration. The **GLT** by Beghelli is offered in AC only, emergency only and always on variations, including test switch. Aesthetically pleasing, yet incredibly durable, the **GLT** can be used in both indoor and outdoor applications. Polycarbonate construction, vandal resistant design and a high performance reflector and diffuser system make for a highly versatile product. Ideal for use in stairwells, closets, corridors, breezeways and under canopies.

DIFFUSER

The diffuser is UV stabilized to reduce the yellowing index and provide superior light output. The co-injection process increases the strength and durability of the diffuser.

REFLECTOR

The reflector is made of injection molded, self-extinguishing, UV stabilized polycarbonate. Vacuum metalization results in a highly reflective surface.

EXTERNAL SPECIFICATIONS

The **GLT** series housing is constructed from high quality corrosion, flame and vandal resistant polycarbonate. Vandal resistant latch clips ensure the integrity of the GL. Mounting locations for ceiling or wall installations are clearly marked on the housing. The **GLT** comes finished in a standard grey RAL 7035 color.

INTERNAL SPECIFICATIONS

The **GLT** series is configured with universal 120/277VAC input. The automatic recharge circuit is regulated by an electronic volt sensor and the battery is protected by a low voltage cut-off circuit.

INSTALLATION

Surface ceiling and wall mounting. Suitable for wet location installations.

ORDERING INFORMATION

Series	Operation	Lamps	Input Voltage
GLT	HT (AC only)	B (2x14w T5)	US (120V)
	SE (emergency only)	C (2x24w T5HO)	US2 (277v)
	SA (AC & Emergency)		UNV (120/277V)
			Must specify 120V or 277V for SA version

GRAN LUCE BUILDER

Series	Lamps	Operation	Input Voltage	Auto-Test	Options

EXAMPLE: GLT-SE-C-US-AT
 DESCRIPTION: Gran Luce emergency luminaire, emergency only, 2x24w T5HO, 120 volt, auto-test

JOB:	TYPE:
-------------	--------------

HIGH-OUTPUT DESIGN

The GLT series unit incorporates an efficient high output lens and reflector. Vacuum metalization technology is used in the manufacturing of the reflector, resulting in a high transmission mirror-like finish. The diffusion lens has been designed to effectively transmit the greatest amount of luminaires with the least transmittal loss. This in turn reduces installation, operational and maintenance costs overall.

IP65 / WET LOCATION GASKETING

The GLT carries an IP65 / Wet location rating. Emergency units are especially vulnerable to fire sprinkler activation since emergency lighting units are often installed right next to sprinkler heads. The IP65 / Wet location rating ensures protection not just from ambient moisture but also from jets of water like those given off by broken or activated sprinkler heads.

VANDAL RESISTANT DESIGN

The GLT series diffuser has been designed to fully enclose and protect the lamp assembly. Vandal resistant flush housing latch clips ensure the integrity of the GLT and discourage fixture tampering.

DIMENSIONS (in.)

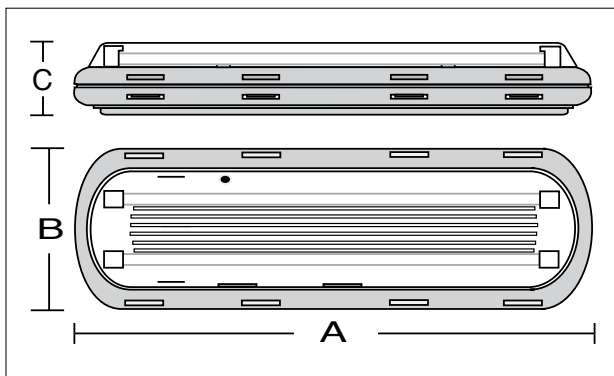

Wattage	A"	B"	C"
1x27W	28 3/8"	6 7/8"	3 9/16"

WARRANTY

The GLT Series comes with a 5-year factory warranty. Lamps are not covered under the warranty. Deliberate damage, misuse, improper installation effectively cancel the warranty.



PRODUCT OVERVIEW

The **STORMGUARD** follows the Beghelli tradition of offering a mix of performance, durability, reliability, and ease of installation. The patented Beghelli ‘Plug in’ connection system make the installation and maintenance an effortless task. The use of fluorescent illumination allows for greater fixture to fixture spacing and an extended lamp life. The **STORMGUARD** is perfect for stairwells, corridors, pool areas, breezeways, patios and parking areas.

REFLECTOR

The **STORMGUARD** reflector is made of injection molded, self-extinguishing, UV stabilized polycarbonate. The reflector supports components including the circuit, battery and lamp holder.

DIFFUSER

The **STORMGUARD** diffuser is UV stabilized to reduce the yellowing index and provide superior light output. The **STORMGUARD** can be configured with either a translucent or clear prismatic diffuser. On average, an increase of +30% light output is achieved by using the clear prismatic diffuser.

EXTERNAL SPECIFICATIONS

The **STORMGUARD** emergency lighting unit housing is corrosion, flame and vandal resistant polycarbonate. The UV stabilized polycarbonate translucent lens or optional clear prismatic lens ensures durability and superior light output.

INTERNAL SPECIFICATIONS

The **STORMGUARD** series uses dedicated 120V or 277V AC. The automatic recharge circuit is regulated by an electronic voltage sensor and the battery is protected by a low voltage cut-off circuit.

INSTALLATION

Surface ceiling or wall mounting. Suitable for wet location installations.

ORDERING INFORMATION

Series	Lamps	Operation	Input Voltage	Options
7	24(1x25W CF, fluorescent)	HT (AC only)	US (120V)	CL (clear lens)
		SE (emergency only)	US2 (277V)	TP (tamper proof kit)

STORMGUARD BUILDER

Series	Lamps	Operation	Input Voltage	Options

EXAMPLE: 724-SE-US-CL

DESCRIPTION: Stormguard emergency luminaire, emergency only, 120 volt, clear lens

JOB:	TYPE:
-------------	--------------

WET LOCATION APPLICATIONS

The need for outdoor emergency lighting is increasing. Areas such as hotels, apartments, condominiums, theaters, hospitals, restaurants and other public areas are implementing outdoor emergency units in order for people to exit these areas in case of a power failure and safely move away from the building. The **STORMGUARD** is ideal for these installations. Corrosion resistant housing and lens ensure outdoor durability. The compact size blends in with the exterior architecture. An optional vandal resistant kit securely keeps the **STORMGUARD** in place. Installed above an exterior door or along a walkway railing; when the power fails, these paths to safety will be effectively illuminated.

VANDAL RESISTANT DESIGNS

An optional tamper proof kit is available when ordering the **STORMGUARD**. Stainless steel tamper proof screws and a screw bit are included. Another vandal resistant option is the full-face wireguard that completely encloses the lens. As well, the **STORMGUARD** lens is 2.70mm thick; this is +1.23mm more than the UL required thickness for a lens (1.47mm). These options make the **STORMGUARD** ideal for installation in schools, health clubs, prisons, warehouses, sports arenas and exterior corridors.

BATTERY & CIRCUIT TECHNOLOGY

The **STORMGUARD** series emergency unit uses an internal 6 volt 5ah sealed lead acid battery that provides a minimum 90 minutes emergency duration. The automatic recharge circuit is regulated by an electronic volt sensor and the battery is protected by a low-voltage cut-off circuit. An input voltage of 120v or 277v must be selected when ordering from the factory.

PLUG IN MOUNTING

The **STORMGUARD** emergency lighting unit uses the Beghelli patented "Plug-In" connection system allowing for easy installation and maintenance.

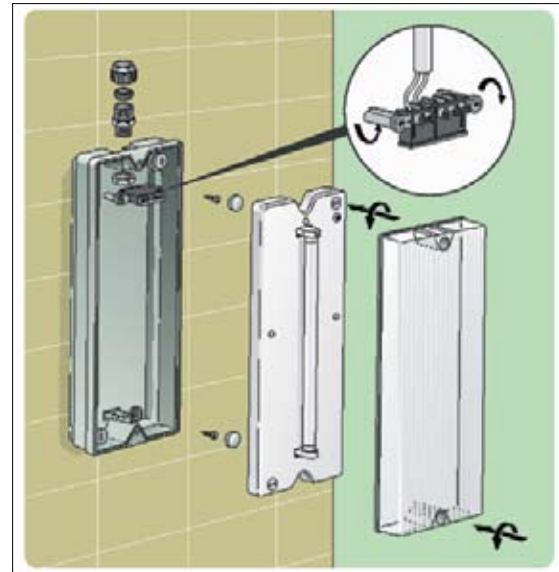

IP65/ WET LOCATION GASKETING

The **STORMGUARD** carries an IP65 / Wet location rating. Emergency units are especially vulnerable to fire sprinkler activation since emergency lighting units are often installed right next to sprinkler heads. The IP65 / Wet location rating ensures protection not just from ambient moisture but also from jets of water like those given off by broken or activated sprinkler heads.

DIMENSIONS (in.)

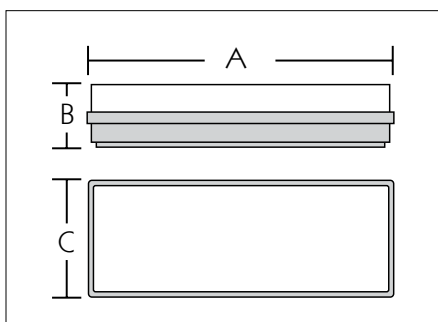

Wattage	A"	B"	C"
1x24W	15 1/2"	3 3/4"	5 7/8"

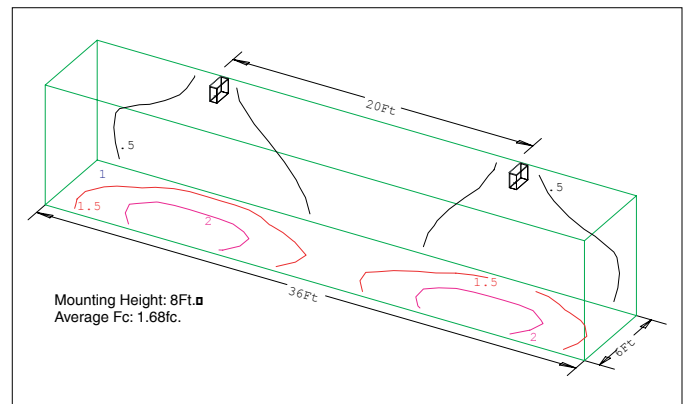

WARRANTY

The **STORMGUARD** Series comes with a 5-year factory warranty. Lamps are not covered under the warranty. Deliberate damage, misuse, improper installation effectively cancel the warranty.

Industrial Application **Emergency**

SECTION THREE



Emergency

EMERGENCY

CONTENTS



ESM Series

Incandescent lamp: 7.2 - 25W	Page
Wall installed product specifications	50
Technical Data	51



Cubico Series

Incandescent lamp: 8 - 20W	Page
Wall installed product specifications vandal resistant	52
Technical Data	53



ESL Series

Incandescent lamp: 7.2 - 25W	Page
Ceiling & Wall installed product specifications.	54
Technical Data	55



EST Series

Incandescent lamp: 7.2- 55W	Page
Wall installed product specification	56
Technical Data	57



HWE Series

Incandescent lamp: 7.2 - 70W	Page
Wall installed product specification	58
Technical Data	59



LDT Series

Incandescent lamp: 7.2 - 55W	Page
Wall installed product specification NEMA 12	60
Technical Data	61



EDT Series

Incandescent lamp: 7.2 - 70W	Page
Wall installed product specification. NEMA 4X, fiberglass housing	62
Technical Data	63



HDT Series

Incandescent lamp: 7.2 - 50W	Page
Wall installed product specification. NEMA 4X, PVC housing.	64
Technical Data	65



VDR Series

Halogen lamp: 10W	Page
Ceiling and wall installed product specification. Vandal Resistant.	66
Technical Data	67



HDZ Series

Multi lamp: 7.2 - 35W	Page
Hazardous area	68
Technical Data	69



HDZ Series

Incandescent lamp: 7.2 - 35W	Page
Hazardous Area	70
Technical Data	71

MECHANICAL SPECIFICATIONS

The **ESM** is constructed from durable 20 gauge steel. The universal mounting pattern stamped into the back of the unit allows for direct mounting to various conduit boxes. Key hole slots are also provided for additional mounting possibilities. Stamped conduit knockouts are supplied standard on all **ESM** units, providing the widest range of options for AC power source connection. The **ESM** is supplied standard in a durable white powder coat, baked finish. Other colors are available, including custom color matching, please specify.

CHARGER SPECIFICATIONS

The **ESM** series utilizes a pulse switching charger that is up to 70% more efficient than traditional constant voltage chargers. The charger is a fully automatic current limited charger with solid state line-latched low voltage disconnect protection. All components used in the circuitry are temperature compensated. The charger also has brownout and short circuit protection. Charger status is easily determined via a dual diagnostic LED display which indicates AC/ON and High Charge. An external push button test switch allows maintenance personnel to quickly determine the operational status of the unit and lamp load.

BATTERY TECHNOLOGY

The **ESM** series is designed with a maintenance free, sealed valve regulated lead acid battery that provides a minimum emergency duration of 90 minutes (for the listed rating). Recharge time of the battery is twenty-four (24) hours. The maximum working temperature is 50°C.

MODEL RATING GUIDE

Model	Voltage	Wattage				Cabinet
		90min	120min	180min	240min	
ESM-6-12	6	12	8	NA	NA	A
ESM-6-18	6	18	12	8	NA	A
ESM-6-27	6	27	20	14	10	A
ESM-6-36	6	36	27	18	12	A
ESM-6-54	6	54	36	27	18	A
ESM-12-36	12	36	27	18	12	A
ESM-12-54	12	54	36	27	18	A

BEGHELLI AUTO-TEST

The **ESM** auto-test feature automatically monitors the functional operation of the unit. Auto-test monitors the operation of the lamps, battery and circuitry and displays any alerts. Periodic emergency tests, up to ninety (90) minutes duration are simulated to ensure proper operation during an actual power failure. Operating status is visually indicated by multi-function LED indication.

DIMENSIONS (in.)

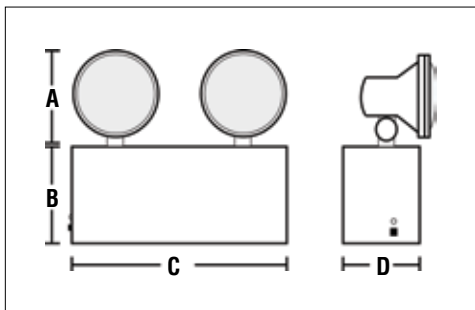

Wattage	A"	B"	C"	D"
12W-54W	6.5"	4.7"	9"	3.2"

WARRANTY

The **ESM** Series comes with a 5-year factory warranty. Lamps are not covered under the warranty. Deliberate damage, misuse, improper installation effectively cancel the warranty.



PRODUCT OVERVIEW

The **CUBICO** series emergency unit has been designed for durability and dependability. This vandal-resistant emergency unit features a high-strength steel housing & high impact resistant polycarbonate lenses. Fully enclosed lamp heads prevent repositioning by unauthorized persons. The **CUBICO** has been designed with the PulseGuard pulse switching charger. The PulseGuard offers superior performance and energy efficiency versus conventional constant voltage chargers. Tamper resistant hardware is standard.

EXTERNAL SPECIFICATIONS

The **CUBICO** series is constructed with a durable 20 gauge steel housing and high impact-resistant lexan polycarbonate lenses that protect the emergency lighting heads. Durable white powder coat finish. External test switch and monitor LED are standard.

INTERNAL SPECIFICATIONS

The **CUBICO** series utilizes the PulseGuard pulse switching charger, which is up to 70% more efficient than constant voltage chargers. 120/277VAC is standard, along with a fully automatic current limited charger, Solid State low voltage disconnect, temperature compensation, brownout protection and short circuit protection. Magnum terminal connectors allow for easy remote load connections.

LAMP SELECTION

- 6V TUNGSTEN: **standard:** 9w
 (H) halogen: 8w, 10w, 12w, 20w
- 12V TUNGSTEN: **standard:** 9w, 18w
 (H) halogen: 8w, 12w, 20w
- 24V TUNGSTEN: **standard:** 9w, 18w
 (H) halogen: 12w, 20w

Surface ceiling or wall mounting. Suitable for indoor installations, 120/277VAC.

See lamp chart on page 142

ORDERING INFORMATION

Series	Operation	Capacity	Heads	Lamps	Options
CUB	6 (volt DC)	12 (6V)	1SR (single Par18)	See lamp guide above	AT (auto-test daignostics)
	12 (volt DC)	18 (6V)	2SR (double par18)		TD (time delay-specify voltage)
		27 (6V)	3SR (triple par18)		NC (nickel-cadmium battery)
		36 (6V, 12V)	4SR (quad par18)		CC (custom color-specify)
		54 (6V, 12V)			VM (voltmeter)
		72 (6V, 12V)			TP (tamper proof screws)
				CS (cord set, 120V only)	
				AM (ammeter)	

CUBICO BUILDER

Series	Operation	Capacity	Heads	Lamps	Options

EXAMPLE: CUB-12-36-2SR12WH-AT
 DESCRIPTION: CUBICO emergency luminaire, emergency only, 120/277V, 12V, 36W, 2 par 18, 12W halogen lamps, auto-test diagnostics.

JOB:	TYPE:
-------------	--------------

MECHANICAL SPECIFICATIONS

The CUBICO is constructed with a durable 20 gauge steel housing. The universal mounting pattern stamped into the back of the unit allows for direct mounting to various conduit boxes. Key hole slots and stamped conduit knockouts are supplied standard on the CUBICO unit, providing the widest range of options for AC power source connection. The Cubico is supplied standard in a durable white powder coat, baked finish. Other colors are available, including customer color matching, please specify.

BATTERY & CIRCUIT TECHNOLOGY

The CUBICO series is designed with a maintenance free, sealed lead calcium battery that provides a minimum emergency duration of 90 minutes. Recharge time of the battery is twenty-four (24) hours. Nickel-Cadmium batteries are available as an option.

LAMP CUBICO FEATURES

The CUBICO series is normally supplied with two (2) 9w heads, Internally mounted, high output mini reflectors designed to optimize light performance.

CHARGER SPECIFICATIONS

The CUBICO series utilizes a pulse switching charger that is up to 70% more efficient than traditional constant voltage chargers. The charger is a fully automatic current limited charger with solid state line-latched low voltage disconnect protection. All components used in the circuitry are temperature compensated. The charger also has brownout and short circuit protection. Charger status is easily determined via a dual diagnostic LED display which indicates AC ON and High Charge.

MODEL RATING GUIDE

Model	Voltage	Wattage				Cabinet
		90min	120min	180min	240min	
CUB-6-27	6	27	18	12	8	A
CUB-6-36	6	36	27	18	12	A
CUB-6-54	6	54	36	27	18	A
CUB-6-72	6	72	54	36	27	B
CUB-12-36	12	36	27	18	14	A
CUB-12-54	12	54	36	27	18	A
CUB-12-72	12	72	54	36	27	B

BEGHELLI AUTO-TEST

The CUBICO auto-test feature automatically monitors the functional operation of the unit. Auto-test monitors the operation of the lamps, battery and circuitry and displays any alerts. Periodic emergency tests, up to ninety (90) minutes duration are simulated to ensure proper operation during an actual power failure. Operating status is visually indicated by multi-function LED indication.

DIMENSIONS (in.)

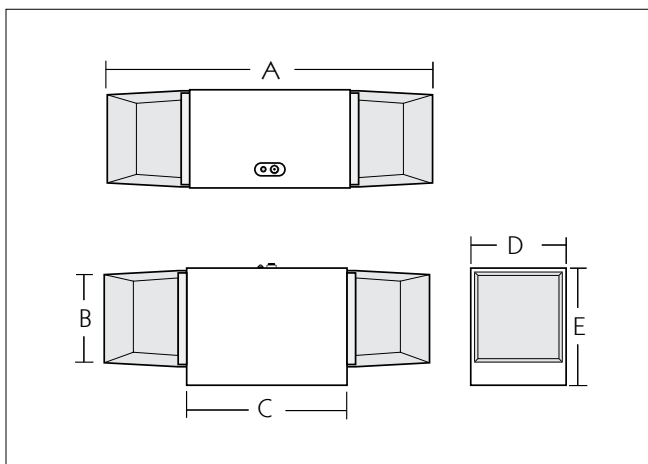

Wattage	A"	B"	C"	D"	Cabinet
12W-54W	21.5"	5"	12"	5.5"	5.57"
72W	27.5"	5"	18"	5.5"	5.57"

WARRANTY

The CUBICO Series comes with a 5-year factory warranty. Lamps are not covered under the warranty. Deliberate damage, misuse, improper installation effectively cancel the warranty.



PRODUCT OVERVIEW

The ESL series of emergency lighting units offers durable construction and architectural design. The ESL housing is constructed from durable 20 gauge steel and finished in a white powder coat. The front access panel is architecturally curved and hinged for trouble-free installation. Top mounted Par36 style EM needs are standard. Front and side mount configurations are available. Universal mounting pattern and conduit knock-outs allow for easy field installation.

EXTERNAL SPECIFICATIONS

The ESL series is constructed with a 20 gauge steel cabinet. Magnum terminal connectors allow for larger gauge wires to be connected for remote loads. White powder coat finish is standard (other colors optional). Emergency lighting heads are molded from high impact thermoplastic in a matching color; LR Par36 style heads are standard, SR Par18 style heads are optional. Universal mounting pattern and key hole slots are stamped on the back and conduit knockouts on the sides of each unit.

INTERNAL SPECIFICATIONS

The ESL series is configured with universal 120/277 VAC input with solid state charging circuitry. Standard features include low voltage disconnect, AC lockout and brownout protection.

INSTALLATION

The ESL luminaire is suitable for surface wall or ceiling and pendant mounting. Suitable for indoor installation on normally inflammable surfaces. 120/277VAC.

LAMP SELECTION

- 6V tungsten: standard: 7.2w, 9w
(H) halogen: 8w, 10w, 12w
- 6V sealed beam: (SB) standard: 9w, 12w
(SBH) halogen: 12w
- 12V tungsten: standard: 9w, 18w
(H) halogen: 8w, 12w,
- 12V sealed beam: (SB) tungsten: 12w, 18w
(SBH) halogen: 8w

See lamp chart on page 142

ORDERING INFORMATION

Series	Operation	Capacity	Heads	Mounting	Lamps	Options
ESL	6 (volt DC)	18 (6V)	1SR (single Par18)	TM (top mount)	See lamp guide above	AT (auto-test daignostics)
	12 (volt DC)	27 (6V)	2SR (double par18)	SM (side mount)		MH (metal heads par 36)
		36 (6V, 12V)	1LR (single par36)	FM (front mount)		NC (nickel-cadmium battery)
			2LR (double par36)			CC (custom color-specify)
		0 (no heads)			VM (voltmeter)	
						TP (tamper proof screws)
						CS (cord set, 120V only)

ESL BUILDER

Series	Operation	Capacity	Heads	Mounting	Lamps	Options

EXAMPLE: ESL-12-36-2LR-TM-7.2W
 DESCRIPTION: ESL emergency luminaire, emergency only, 120/277, 12V, 36W, par36, top mount, 7.2W lamps.

JOB:	TYPE:
-------------	--------------

MECHANICAL SPECIFICATIONS

The **ESL** is constructed from a solid and durable 20 gauge steel housing. The universal mounting pattern stamped into the back of the unit allows for direct mounting to various conduit boxes. Key hole slots are also provided for additional mounting possibilities. Stamped conduit knockouts are supplied standard on all **ESL** units, providing the widest range of options for AC power source connection. The **ESL** is supplied standard in a durable white powder coat, baked finish. Other colors are available, including custom color matching, please specify.

CHARGER SPECIFICATIONS

The **ESL** series utilizes a pulse switching charger that is up to 70% more efficient than traditional constant voltage chargers. The charger is a fully automatic current limited charger with solid state line-latched low voltage disconnect protection. All components used in the circuitry are temperature compensated. The charger also has brownout and short circuit protection. Charger status is easily determined via a dual diagnostic LED display which indicates AC/ON and High Charge. An external push button test switch allows maintenance personnel to quickly determine the operational status of the unit and lamp load.

DIMENSIONS (in.)

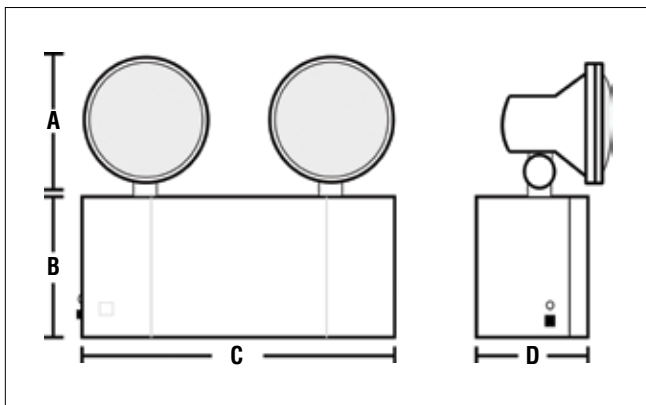

Wattage	A"	B"	C"	D"
18W-36W	5.5"	5.2"	11"	5.3"

BATTERY TECHNOLOGY

The **ESL** series is designed with a maintenance free, sealed valve regulated lead acid battery that provides a minimum emergency duration of 90 minutes (for the listed rating). Recharge time of the battery is twenty-four (24) hours. The maximum working temperature is 50° C.

MODEL RATING GUIDE

Model	Voltage	Wattage				Cabinet
		90min	120min	180min	240min	
ESL-6-18	6	18	12	8	NA	A
ESL-6-27	6	27	20	14	NA	A
ESL-6-36	6	36	27	20	14	A
ESL-12-36	12	36	27	20	14	A

LAMP HEAD FEATURES

The **ESL** series is normally supplied with two (2) front mounted (LR) Par36 style heads. Smaller (SR) Par18 style heads are optional. The **ESL** can be configured with front, side or top mounted heads, please specify when ordering. Both lamp head styles are constructed of high impact thermoplastic in a color matching the finish of the cabinet (white is standard). Both head types feature a unique twist locking collar that securely holds the lens and facilitates quick and easy re-lamping.

BEGHELLI AUTO-TEST

The **ESL** auto-test feature automatically monitors the functional operation of the unit. Auto-test monitors the operation of the lamps, battery and circuitry and displays any alerts. Periodic emergency tests, up to ninety (90) minutes duration are simulated to ensure proper operation during an actual power failure. Operating status is visually indicated by multi-function LED indication

WARRANTY

The **ESL** Series comes with a 5-year factory warranty. Lamps are not covered under the warranty. Deliberate damage, misuse, improper installation effectively cancel the warranty.

MECHANICAL SPECIFICATIONS

The **EST** is constructed from a solid and durable 20 gauge steel housing. The universal mounting pattern stamped into the back of the unit allows for direct mounting to various conduit boxes. Key hole slots and conduit knockouts are provided for additional mounting possibilities. Remote lamp loads are connected to the emergency power supply with sturdy magnum terminal connectors. These connectors allow for a large gauge of wire to be used increasing the flexibility of installation. The **EST** is supplied standard in a durable white powder coat, baked finish. Other colors are available, including custom color matching, please specify.

CHARGER SPECIFICATIONS

The **EST** series utilizes a pulse switching charger that is up to 70% more efficient than traditional constant voltage chargers. The charger is a fully automatic current limited charger with solid state line-latched low voltage disconnect protection. All components used in the circuitry are temperature compensated. The charger also has brownout and short circuit protection. Charger status is easily determined via a dual diagnostic LED display which indicates AC/ON and High Charge. An external push button test switch allows maintenance personnel to quickly determine the operational status of the unit and lamp load.

LAMP HEAD FEATURES

The **EST** series is normally supplied with two (2) top mounted (LR) Par36 style 9w heads. (SR) Par18 style heads are optional. Lamp heads can be mounted either on the top or on the sides of the unit allowing for up to five (5) heads to be mounted on the largest units (3 top, 2 side). Both lamp head styles are constructed of high impact thermoplastic in a color matching the finish of the cabinet (white is standard). Both head types feature a unique twist locking collar that securely holds the lens and facilitates quick and easy re-lamping.

DIMENSIONS (in.)

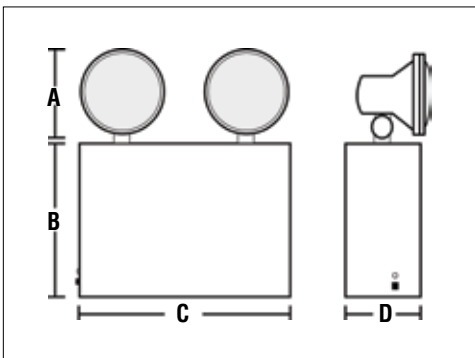

Wattage	A"	B"	C"	D"
27W-100W	6"	9"	12"	3.1"

BATTERY TECHNOLOGY

The **EST** series is designed with a maintenance free, sealed valve regulated lead acid battery that provides a minimum emergency duration of 90 minutes (for the listed rating). Recharge time of the battery is twenty-four (24) hours. The maximum working temperature is 50° C

MODEL RATING GUIDE

Model	Voltage	Wattage				Cabinet
		90min	120min	180min	240min	
EST-6-27	6	27	18	12	8	A
EST-6-36	6	36	27	20	14	A
EST-6-54	6	54	36	27	18	
EST-6-72	6	72	54	36	27	A
EST-6-100	6	100	72	54	36	A
EST-6-125	6	125	100	72	54	A
EST-12-36	12	36	27	20	14	A
EST-12-54	12	54	36	27	18	A
EST-12-72	12	72	54	36	27	A
EST-12-100	12	100	72	54	36	A
EST-12-100	12	125	100	72	54	A

BEGHELLI AUTO-TEST

The **EST** auto-test feature automatically monitors the functional operation of the unit. Auto-test monitors the operation of the lamps, battery and circuitry and displays any alerts. Periodic emergency tests, up to ninety (90) minutes duration are simulated to ensure proper operation during an actual power failure. Operating status is visually indicated by multi-function LED indication

WARRANTY

The **EST** Series comes with a 5-year factory warranty. Lamps are not covered under the warranty. Deliberate damage, misuse, improper installation effectively cancel the warranty.



PRODUCT OVERVIEW

The HWE series of emergency lighting units are a family of specification grade 6, 12 and 24 volt battery units designed with the PulseGuard pulse switching charger. The PulseGuard offers superior performance and energy efficiency versus conventional constant voltage chargers. Traditional top mounted (LR) Par36 style heads are standard, (SR) Par18 style small heads are optional.

EXTERNAL SPECIFICATIONS

The HWE series is constructed with a 20 gauge steel cabinet. Magnum terminal connectors allow for larger gauge wires to be connected for remote loads. White finish is standard (other colors optional). Emergency lighting heads are molded from high impact thermoplastic in a matching color; (LR) Par36 style heads are standard, (SR) Par18 style heads are optional. Universal mounting pattern and key hole slots are stamped on the back and conduit knockouts on the sides of each unit.

INTERNAL SPECIFICATIONS

The HWE series is configured with universal 120/277 VAC input with solid state charging circuitry. Standard features include low voltage disconnect, AC lockout and brownout protection.

INSTALLATION

The HWE luminaire is suitable for surface wall mounting. Suitable for indoor installation. 120/277VAC.

LAMP SELECTION

- 6V tungsten: **standard:** 9w
 (H) halogen: 8w, 10w, 12w, 20w
- 6V sealed beam: (SB) **standard:** 9w, 12w, 18w
 (SBH) halogen: 12w, 20w
- 12V tungsten: **standard:** 9w, 18w
 (H) halogen: 8w, 12w, 20w, *35w, *55w(*LR only)
- 12V sealed beam: (SB) **standard:** 12w, 18w
 (SBH) halogen: 8w
- 24V tungsten: (SB) **standard:** 9w, 12w, *24w (*LR only)
 (H) halogen: *20w, *70w (*LR only)

See lamp chart on page 142

ORDERING INFORMATION

Series	Operation	Capacity	Heads	Lamps	Options
HWE	6 (volt DC)	125 (6V, 12V)	1SR (single Par18)	See lamp guide above	AT (auto-test daignostics)
	12 (volt DC)	150 (6V, 12V)	2SR (double par18)		TD (time delay-specify voltage)
	24 (volt DC)	200 (6V, 12V, 24V)	1LR (single par36)		NC (nickel-cadmium battery)
		300 (6V, 12V, 24V)	2LR (double par36)		CC (custom color-specify)
		400 (12V, 24V)	0 (no heads)		VM (voltmeter)
				TP (tamper proof screws)	
				CS (cord set, 120V only)	
				AM (ammeter)	
				MH (metal heads par36)	

HWE BUILDER

Series	Operation	Capacity	Heads	Lamps	Options

EXAMPLE: HWE-12-300-2LR-35W(H)-TD(277V)

DESCRIPTION: HWE emergency luminaire, emergency only, 120/277, 12V, 300W, 35W halogen lamp, 2 par36, time delay 277V.

JOB:	TYPE:
-------------	--------------

MECHANICAL SPECIFICATIONS

The **HWE** is constructed from a solid and durable 20 gauge steel housing. The universal mounting pattern stamped into the back of the unit allows for direct mounting to various conduit boxes. Key hole slots and stamped conduit knockouts are supplied standard on all **HWE** units, providing the widest range of options for AC power source connection. Remote lamp loads are connected to the emergency power supply with sturdy magnum terminal connectors. These connectors allow for a large gauge of wire to be used increasing the flexibility of installation. The **HWE** is supplied standard in a durable white powder coat, baked finish. Other colors are available, including custom color matching, please specify.

CHARGER SPECIFICATIONS

The **HWE** series utilizes a pulse switching charger that is up to 70% more efficient than traditional constant voltage chargers. The charger is a fully automatic current limited charger with solid state line-latched low voltage disconnect protection. All components used in the circuitry are temperature compensated. The charger also has brownout and short circuit protection. Charger status is easily determined via a dual diagnostic LED display which indicates AC/ON and High Charge. An external push button test switch allows maintenance personnel to quickly determine the operational status of the unit and lamp load.

LAMP HEAD FEATURES

The **HWE** series is normally supplied with two (2) top mounted (LR) Par36 style 9w heads. Lamp heads can be mounted either on the top or on the sides of the unit allowing for up to five (5) heads to be mounted (3 top, 2 sides). Both (LR) Par36 and (SR) Par18 lamp head styles are constructed of high impact thermoplastic in a color matching the finish of the cabinet (white is standard). Both head types feature a unique twist locking collar that securely holds the lens and facilitates quick and easy re-lamping.

DIMENSIONS (in.)

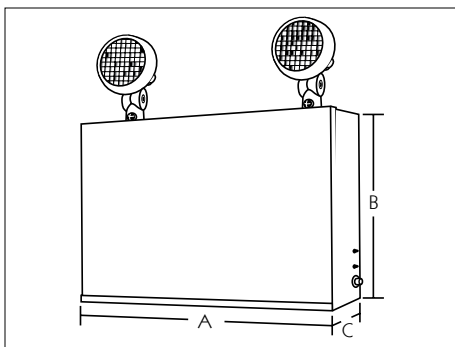

Wattage	A"	B"	C"	D"
125W-200W	6"	10"	13.1"	8.2"
300W-400W	6"	10"	18.05"	8.32"

BATTERY TECHNOLOGY

The **HWE** series is designed with a maintenance free, sealed valve regulated lead acid battery that provides a minimum emergency duration of 90 minutes (for the listed rating). Recharge time of the battery is twenty-four (24) hours. The maximum working temperature is 50° C.

MODEL RATING GUIDE

Model	Voltage	Wattage				Cabinet
		90min	120min	180min	240min	
HWE-6-125	6	125	100	72	54	A
HWE-6-150	6	150	125	100	72	A
HWE-6-200	6	200	150	125	100	
HWE-12-125	12	125	100	72	54	A
HWE-12-150	12	150	125	100	72	A
HWE-12-200	12	200	150	125	100	A
HWE-12-300	12	300	200	150	125	A
HWE-12-400	12	400	300	200	150	A
HWE-24-200	24	200	150	125	100	A
HWE-24-300	24	300	200	150	125	A
HWE-24-400	24	400	300	200	150	A

BEGHELLI AUTO-TEST (AT)

The **HWE** auto-test feature automatically monitors the functional operation of the unit. Auto-test monitors the operation of the lamps, battery and circuitry and displays any alerts. Periodic emergency tests, up to ninety (90) minutes duration are simulated to ensure proper operation during an actual power failure. Operating status is visually indicated by multi-function LED indication.

WARRANTY

The **HWE** Series comes with a 5-year factory warranty. Lamps are not covered under the warranty. Deliberate damage, misuse, improper installation effectively cancel the warranty.



PRODUCT OVERVIEW

The **LDT** series of industrial emergency lighting units are designed for durability and dependability. The NEMA 12 gasketed steel housing can be used in areas that generate dust, lint, fibers, dripping water and condensation. The **LDT** is designed with the PulseGuard pulse switching charger. The PulseGuard offers superior performance and energy efficiency versus conventional constant voltage chargers. Traditional top mounted (LR) Par36 style heads are standard, (SR) Par18 style heads are optional.

ORDERING INFORMATION

Series	Operation	Capacity	Heads	Lamps	Options
LDT	6 (volt DC)	27 (6V)	1SR (single Par18)	See lamp guide above	AT (auto-test diagnostics)
	12 (volt DC)	36 (6V, 12V)	2SR (double par18)		TD (time delay-specify voltage)
		54 (6V, 12V)	1LR (single par36)		NC (nickel-cadmium battery)
		72 (6V, 12V)	2LR (double par36)		FP (food prep lens)
		100 (6V, 12V)	0 (no heads)		VM (voltmeter)
				TP (tamper proof screws)	
					CS (cord set, 120V only)
					AM (ammeter)
					MH (metal heads par36)
					IH (internal heater)

LDT BUILDER

Series	Operation	Capacity	Heads	Lamps	Options

EXAMPLE: LDT-6-54-2LR-20W(SBH)-VM
 DESCRIPTION: LDT emergency luminaire, emergency only, 120/277, 6V, 54W, 20W(sealed beam halogen) lamp, 2 par36, voltmeter.

JOB:	TYPE:
-------------	--------------

EXTERNAL SPECIFICATIONS

The **LDT** series is constructed with a 16 gauge steel cabinet. Magnum terminal connectors allow for larger gauge wires to be connected for remote loads. Industrial gray powder coat finish is standard. Emergency lighting heads are molded from high impact thermoplastic, (LR) Par36 style are standard, (SR) Par18 style are optional. The **LDT** features integrated mounting feet that ensure positive and secure installations. External test switch & monitor LED are standard.

INTERNAL SPECIFICATIONS

The **LDT** series is configured with universal 120/277 VAC input with solid state charging circuitry. Standard features include low voltage disconnect, AC lockout and brownout protection.

INSTALLATION

The **LDT** luminaire is suitable for surface wall mounting. Suitable for NEMA 12 required installations.

LAMP SELECTION

- 6V tungsten: **standard:** 9w
 (H) halogen: 8w, 10w, 12w, 20w
- 6V sealed beam: (SB) **standard:** 9w, 12w, 18w
 (SBH) halogen: 12w, 20w
- 12V tungsten: **standard:** 9w, 18w
 (H) halogen: 8w, 12w, 20w, *35w, (*LR only)
- 12V sealed beam: (SB) **standard:** 12w, 18w
 (SBH) halogen: 8w

See lamp chart on page 142

MECHANICAL SPECIFICATIONS

The LDT is constructed from a solid and durable 16 gauge steel housing. The integrated mounting feet allow for direct and secure mounting to most surfaces. A fully gasketed and hinged front access panel allow for trouble-free installation and maintenance. Remote lamp loads are connected to the emergency power supply with sturdy magnum terminal connectors. These connectors allow for a large gauge of wire to be used increasing the flexibility of installation. The LDT is supplied standard in a durable industrial grey powder coat finish.

CHARGER SPECIFICATIONS

The LDT series utilizes a pulse switching charger that is up to 70% more efficient than traditional constant voltage chargers. The charger is a fully automatic current limited charger with solid state line-latched low voltage disconnect protection. All components used in the circuitry are temperature compensated. The charger also has brownout and short circuit protection. Charger status is easily determined via a dual diagnostic LED display which indicates AC/ON and High Charge. An external push button test switch allows maintenance personnel to quickly determine the operational status of the unit and lamp load.

LAMP HEAD FEATURES

The LDT series is normally supplied with two (2) top mounted (LR) Par36 style 9w heads. Optional (SR) Par18 style heads are available. Both lamp head styles are constructed of high impact thermoplastic. Both head types feature a unique twist locking collar that securely holds the lens and facilitates quick and easy re-lamping. Please note: (LR) Par36 style metal heads and food-prep approved lenses are also available when ordering.

DIMENSIONS (in.)

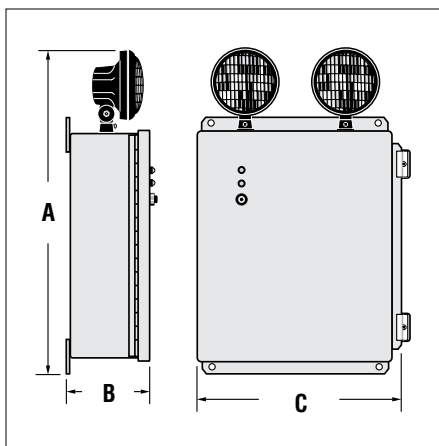

Wattage	A"	B"	C"
27W-100W	18"	5.4"	12.7"

BATTERY TECHNOLOGY

The LDT series is designed with a maintenance free, sealed valve regulated lead acid battery that provides a minimum emergency duration of 90 minutes (for the listed rating). Recharge time of the battery is twenty-four (24) hours. The maximum working temperature is 50° C.

MODEL RATING GUIDE

Model	Voltage	Wattage				Cabinet
		90min	120min	180min	240min	
LDT-6-27	6	27	18	12	8	A
LDT-6-36	6	36	27	18	12	A
LDT-6-54	6	54	36	27	18	A
LDT-6-72	6	72	54	36	27	A
LDT-6-100	6	100	72	54	36	A
LDT-12-36	12	36	27	18	12	A
LDT-12-54	12	54	36	27	18	A
LDT-12-72	12	72	54	36	27	A
LDT-12-100	12	100	72	54	36	A

BEGHELLI AUTO-TEST

The LDT auto-test feature automatically monitors the functional operation of the unit. Auto-test monitors the operation of the lamps, battery and circuitry and displays any alerts. Periodic emergency tests, up to ninety (90) minutes duration are simulated to ensure proper operation during an actual power failure. Operating status is visually indicated by multi-function LED indication.

WARRANTY

The LDT Series comes with a 5-year factory warranty. Lamps are not covered under the warranty. Deliberate damage, misuse, improper installation effectively cancel the warranty.



PRODUCT OVERVIEW

The EDT series of industrial emergency lighting units are designed to be affordable, durable and dependable. The NEMA 4x rated fiberglass housing can be used in most damp, wet and hose down areas. The EDT series has been designed with the PulseGuard pulse switching charger. The PulseGuard offers superior performance & energy efficiency versus conventional constant voltage chargers. Traditional top mounted (LR) Par36 style heads are standard.

EXTERNAL SPECIFICATIONS

The EDT series is constructed with a durable NEMA 4x rated fiberglass cabinet. Industrial gray finish is standard. Emergency lighting heads are molded from high impact thermoplastic, (LR) Par36 style heads are standard. Integrated mounting feet ensure proper and secure installation. External test switch and monitor LED are standard.

INTERNAL SPECIFICATIONS

The EDT series is configured with universal 120/277 VAC input with solid state charging circuitry. Standard features include low voltage disconnect, AC lockout and brownout protection.

INSTALLATION

The EDT luminaire is suitable for surface wall mounting. Suitable for NEMA 4x required installations. 120/277VAC.

LAMP SELECTION

- 6V tungsten: standard: 9w
 (H) halogen: 8w, 10w, 12w, 20w
- 6V sealed beam: (SB) standard: 9w, 12w, 18w
 (SBH) halogen: 12w, 20w
- 12V tungsten: standard: 9w, 18w
 (H) halogen: 8w, 12w, 20w, *35w, *55w (*LR only)
- 12V sealed beam: (SB) standard: 12w, 18w
 (SBH) halogen: 8w

See lamp chart on page 142

ORDERING INFORMATION

Series	Operation	Capacity	Heads	Lamps	Options
EDT	6 (volt DC)	27 (6V)	1LR (single par36)	See lamp guide above	AT (auto-test daignostics)
	12 (volt DC)	36 (6V, 12V)	2LR (double par36)		TD (time delay-specify voltage)
		54 (6V, 12V)	0 (no heads)		NC (nickel-cadmium battery)
		72 (6V, 12V)			FP (food prep lens)
		100 (6V, 12V)			VM (voltmeter)
		200 (6V, 12V, 24V)			CC (custom color)
		300 (6V, 12V, 24V)			AM (ammeter)
		400 (12V, 24V)			IH (internal heater)

EDT BUILDER

Series	Operation	Capacity	Heads	Lamps	Options

EXAMPLE: EDT-6-36-2LR-8W(H)-TD(120V)
 DESCRIPTION: EDT emergency luminaire, emergency only, 120/277, 6v, 36w, 8w halogen lamp, 2 par36, time delay 120V.

JOB:	TYPE:
-------------	--------------

MECHANICAL SPECIFICATIONS

The EDT is constructed from a durable, fully gasketed NEMA 4x rated fiberglass housing. The front access panel is hinged for trouble-free installation and maintenance. Four integrated mounting feet ensure proper, secure and accurate wall or ceiling installation on to most surfaces. The EDT is supplied standard in an industrial gray fiberglass finish.

CHARGER SPECIFICATIONS

The EDT series utilizes a pulse switching charger that is up to 70% more efficient than traditional constant voltage chargers. The charger is a fully automatic current limited charger with solid state line-latched low voltage disconnect protection. All components used in the circuitry are temperature compensated. The charger also has brownout and short circuit protection. Charger status is easily determined via a dual diagnostic LED display which indicates AC/ON and High Charge. An external push button test switch allows maintenance personnel to quickly determine the operational status of the unit and lamp load.

LAMP HEAD FEATURES

The EDT series is normally supplied with two (2) top mounted (LR) Par36 style 9w heads. Lamp head styles are constructed of high impact thermoplastic. Please note: (LR) Par36 style food-prep approved lenses are also available when ordering.

DIMENSIONS (in.)

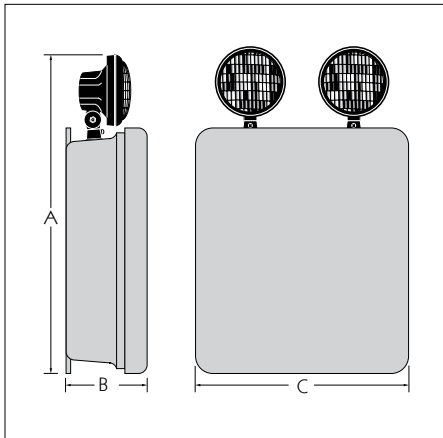

Wattage	A"	B"	C"	D "
27W-36W	6"	7.5"	15.5"	6.25"
54W-72W	6"	13.5"	11.5"	5.25"
100W-200W	6"	15.5"	13.5"	6.25"
300W-400W	6"	19.75"	17.75"	8"

BEGHELLI AUTO TEST

The EDT auto-test feature automatically monitors the functional operation of the unit. Auto-test monitors the operation of the lamps, battery and circuitry and displays any alerts. Periodic emergency tests, up to ninety (90) minutes duration are simulated to ensure proper operation during an actual power failure. Operating status is visually indicated by multi-function LED indication.

MODEL RATING GUIDE

Model	Voltage	Wattage				Cabinet
		90min	120min	180min	240min	
EDT-6-27	6	27	18	12	8	A
EDT-6-36	6	36	27	18	12	B
EDT-6-54	6	54	36	27	18	C
EDT-6-72	6	72	54	36	27	C
EDT-6-100	6	100	72	54	36	C
EDT-12-36	12	36	27	18	12	B
EDT-12-54	12	54	36	27	18	C
EDT-12-72	12	72	54	36	27	C
EDT-12-100	12	100	72	54	36	C
EDT-12-200	12	200	100	72	54	D
EDT-12-300	12	300	200	100	72	E
EDT-12-400	12	400	400	200	100	F

BATTERY TECHNOLOGY

The EDT series is designed with a maintenance free, sealed valve regulated lead acid battery that provides a minimum emergency duration of 90 minutes (for the listed rating). Recharge time of the battery is twenty-four (24) hours. The maximum working temperature is 50° C.

WARRANTY

The EDT Series comes with a 5-year factory warranty. Lamps are not covered under the warranty. Deliberate damage, misuse, improper installation effectively cancel the warranty.

MECHANICAL SPECIFICATIONS

The **HDT** is constructed from a durable, fully gasketed NEMA 4x rated PVC housing. The front access panel is hinged for trouble-free installation and maintenance. Four integrated mounting feet ensure proper, secure and accurate wall or ceiling installation on to most surfaces. The **HDT** is supplied standard in an industrial gray PVC finish. External test switch and monitor LED standard.

CHARGER SPECIFICATIONS

The **HDT** series utilizes a pulse switching charger that is up to 70% more efficient than older constant voltage chargers. The charger is a fully automatic current limited charger with solid state line-latched low voltage disconnect protection. All components used in the circuitry are temperature compensated. The charger also has brownout and short circuit protection. Charger status is easily determined via a dual diagnostic LED display which indicates AC/ON and High Charge. An external push button test switch allows maintenance personnel to quickly determine the operational status of the unit and lamp load.

LAMP HEAD FEATURES

The **HDT** series is normally supplied with two (2) top mounted (LR) Par36 style 9w heads. Lamp head styles are constructed of high impact thermoplastic. Please note: (LR) Par36 style food-prep approved lenses are also available when ordering.

BATTERY TECHNOLOGY

The **HDT** series is designed with a maintenance free, sealed valve regulated lead acid battery that provides a minimum emergency duration of 90 minutes (for the listed rating). Recharge time of the battery is twenty-four (24) hours. The maximum working temperature is 50° C.

BEGHELLI AUTO-TEST (AT)

The **HDT** auto-test feature automatically monitors the functional operation of the unit. Auto-test monitors the operation of the lamps, battery and circuitry and displays any alerts. Periodic emergency tests, up to ninety (90) minutes duration are simulated to ensure proper operation during an actual power failure. Operating status is visually indicated by multi-function LED indication.

MODEL RATING GUIDE

Model	Voltage	Wattage				Cabinet
		90min	120min	180min	240min	
HDT-6-27	6	27	18	12	8	A
HDT-6-36	6	36	27	18	12	A
HDT-6-54	6	54	36	27	18	B
HDT-6-72	6	72	54	36	27	B
HDT-6-100	6	100	72	54	36	C
HDT-12-36	12	36	27	18	12	A
HDT-12-54	12	54	36	27	18	B
HDT-12-72	12	72	54	36	27	B
HDT-12-100	12	100	72	54	36	C

DIMENSIONS (in.)

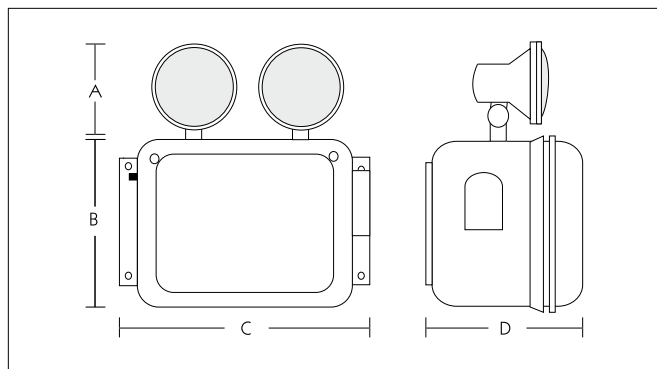

Wattage	A"	B"	C"	D "
27W-36W	6.2"	8"	10"	5"
54W-72W	6.2"	10"	12"	7"
100W	6.2"	12"	14"	7"

WARRANTY

The **HDT** Series comes with a 5-year factory warranty. Lamps are not covered under the warranty. Deliberate damage, misuse, improper installation effectively cancel the warranty.



PRODUCT OVERVIEW

The VDR series of emergency lighting units are constructed from durable and secure polycarbonate and 18 gauge steel. The VDR has been designed with the PulseGuard pulse switching charger. The PulseGuard offers superior performance and energy efficiency versus conventional constant voltage chargers. Single or double 10 watt halogen lamps can be ordered. Tamper resistant hardware is standard.

EXTERNAL SPECIFICATIONS

The VDR series is constructed with an 18 gauge steel housing and impact resistant polycarbonate diffuser. White powder coat finish is standard (other colors optional). Internal emergency light source available configured with single or double 10 watt halogen lamps. Conduit knockouts are located on (3) three sides and the back of each unit. External test switch and monitor LED are standard.

INTERNAL SPECIFICATIONS

The VDR series is configured with universal 120/277 VAC input with solid state charging circuitry. Standard features include low voltage disconnect, AC lockout and brownout protection.

INSTALLATION

The VDR emergency luminaire is suitable for surface wall or ceiling mounting. Suitable for indoor installations. 120/277VAC.

ORDERING INFORMATION

Series	Model	Operation	Capacity	Heads	Options
HDT	HT (AC only)	6 (volt DC)	12 (6V)	110 (single 10W)	AT (auto-test daignostics)
	SA (AC & Emergency)	12 (volt DC)	22 (6V, 12V)	210 (Double 10W)	TD (time delay-specify voltage) NC (nickel-cadmium battery) FP (food prep lens) VM (voltmeter)

VDR BUILDER

Series	Model	Operation	Capacity	Heads	Options

EXAMPLE: VDR-SA-6-22-210

DESCRIPTION: VDR series luminaire, AC & Emergency only, 120/277, 2x10W halogen lamps.

Note: When ordering HT version (AC only), do not specify operation/capacity.

JOB:	TYPE:
-------------	--------------

MECHANICAL SPECIFICATIONS

The **VDR** is constructed with a durable 18 gauge steel housing and impact, corrosion and flame resistant polycarbonate diffuser. Stamped conduit knockouts are located on (3) three sides and the back of the **VDR** unit. The **VDR** is supplied standard in a durable white powder coat, baked finish. Other colors are available, including custom color matching, please specify. External test switch and monitor LED are standard.

CHARGER SPECIFICATIONS

The **VDR** series utilizes a pulse switching charger that is up to 70% more efficient than traditional constant voltage chargers. The charger is a fully automatic current limited charger with solid state line-latched low voltage disconnect protection. All components used in the circuitry are temperature compensated. The charger also has brownout and short circuit protection. Charger status is easily determined via a dual diagnostic LED display which indicates AC/ON and High Charge. An external push button test switch allows maintenance personnel to quickly determine the operational status of the unit and lamp load.

LAMP HEAD FEATURES

The **VDR** series is normally supplied with (1) one or (2) two internally mounted 10 watt halogen lamps. Please specify the lamp configuration required when ordering.

BATTERY TECHNOLOGY

The **VDR** series is designed with a maintenance free, sealed valve regulated lead acid battery that provides a minimum emergency duration of 90 minutes (for the listed rating). Recharge time of the battery is twenty-four (24) hours. The maximum working temperature is 50° C.

BEGHELLI AUTO-TEST (AT)

The **VDR** auto-test feature automatically monitors the functional operation of the unit. Auto-test monitors the operation of the lamps, battery and circuitry and displays any alerts. Periodic emergency tests, up to ninety (90) minutes duration are simulated to ensure proper operation during an actual power failure. Operating status is visually indicated by multi-function LED indication.

MODEL RATING GUIDE

Model	Voltage	Wattage				Cabinet
		90min	120min	180min	240min	
VDR-6-12	6	12	8	NA	NA	A
VDR-6-22	6	22	12	8	NA	A
VDR-12-22	12	22	12	8	NA	A

DIMENSIONS (in.)

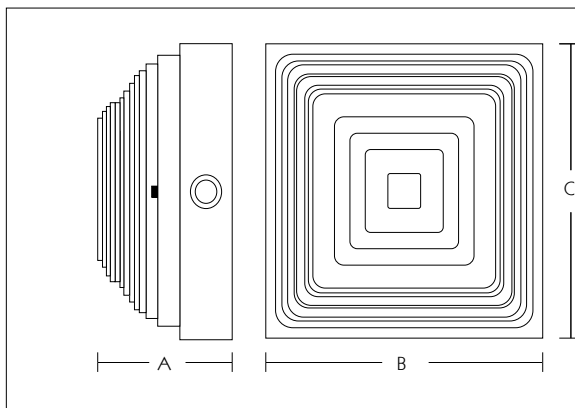

Wattage	A"	B"	C"
12W-22W	6"	9"	9"

WARRANTY

The **VDR** series comes with a 5-year factory warranty. Lamps are not covered under the warranty. Deliberate damage, misuse, improper installation effectively cancel the warranty.



PRODUCT OVERVIEW

The HDZ series offers emergency and exit illumination that is designed to perform in hazardous environments. The HDZ series is approved for installation in NEC Class I, Divisions 1 or 2, Groups C & D; or Class II, Divisions 1 or 2, Groups E, F and G areas. The HDZ series uses copper-free cast aluminum housings that offer trouble-free installation and durability.

EXTERNAL SPECIFICATIONS

The HDZ series housings are constructed from corrosion resistant, copper-free cast aluminum. The quick access thread on cover allows for trouble-free installation and reduces general maintenance time. A one-way stainless breather provides proper and effective unit ventilation. Internal test switch and monitor LED are standard. The HDZ series is capable of supporting remote emergency fixtures and exit signage.

INTERNAL SPECIFICATIONS

The HDZ series is configured with universal 120/277 VAC input with solid state charging circuitry. Standard features include low voltage disconnect, AC lockout and brownout protection.

INSTALLATION

The HDZ luminaire is suitable for surface wall or ceiling and pendant mounting. Suitable for installation and operation in NEC Class I, Div 1 or 2, Groups C & D; or Class II, Div 1 or 2, Groups E, F & G areas.

LAMP SELECTION

- 6V halogen: 8WH, 10WH, 12WH, 20WH
- 12V halogen: 8WH, 12WH, 20WH
- 24V halogen: 12WH, 20WH
- 120V compact: (CF) compact fluorescent: 2 x 13W

ORDERING INFORMATION

Series	Operation	Capacity	Class	Div.	Groups	Light/EXIT	#of Lamps	Mounting	Options
HDZ	6 (volt DC)	26 (120V CF)	C1 (i)	D1 (i)	B	0 (none)	1 (single lamp)	CM (ceiling mount)	AT (auto-test)
	12 (volt DC)	36 (6V, 12V)	C2 (ii)	D2 (ii)	C	L1 (single head)	2 (double lamp)	PM (pendant mount)	RF (reflector hood)
	24 (volt DC)	54 (6V, 12V)			D	L2 (double head)	Note: see lamp guide	WM (wall mount)	WG (wireguard)
	120 (volt DC)	100 (6V, 12V)			E	X1 (single face exit)			GL (green lens)
					F	X2 (double face exit)			TD (Time delay)
					G				NC (nicad battery)

HDZ BUILDER

Series	Operation	Capacity	Light/EXIT	#of Lamps	Mounting	Options

EXAMPLE: HDZ-6-36-C1-D1-CD-L1-X1-2-CM-TD(277)
 DESCRIPTION: HDZ emergency luminaire 6V36W class1, division1, groups C & D, single head, double lamp, single face exit, time delay (277V)

JOB:	TYPE:
-------------	--------------

MECHANICAL SPECIFICATIONS

The HDZ series is constructed from corrosion resistant, copper free aluminum. The quick access thread-on cover allows for trouble-free installation and maintenance. The HDZ series incorporates a one way stainless steel breather that provides proper unit ventilation. External test switch and monitor LED are standard.

CHARGER SPECIFICATIONS

The HDZ series utilizes a pulse switching charger that is up to 70% more efficient than traditional constant voltage chargers. The charger is a fully automatic current limited charger with solid state line-latched low voltage disconnect protection. All components used in the circuitry are temperature compensated. The charger also has brownout and short circuit protection. An external push button test switch allows maintenance personnel to quickly determine the operational status of the unit and lamp load.

CONFIGURATIONS

The HDZ series utilizes a pulse switching charger that is up to 70% more efficient than traditional constant voltage chargers. The charger is a fully automatic current limited charger with solid state line-latched low voltage disconnect protection. All components used in the circuitry are temperature compensated. The charger also has brownout and short circuit protection. An external push button test switch allows maintenance personnel to quickly determine the operational status of the unit and lamp load.

DIMENSIONS (in.)

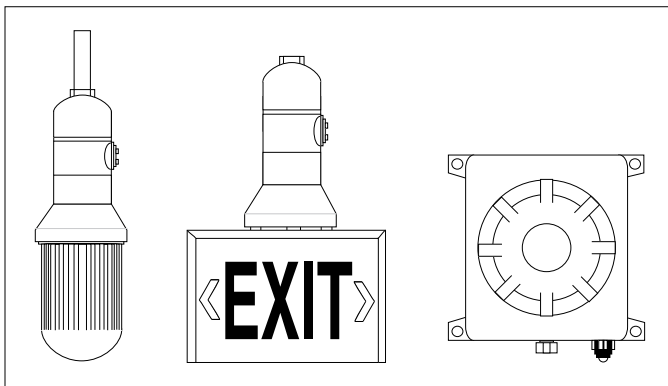

Wattage	A"	B"	C"
36W-100W	Please consult factory for dimensions		
2x13W	Please consult factory for dimensions		
L1, L2, L3	Please consult factory for dimensions		
X1, X2	Please consult factory for dimensions		

BATTERY TECHNOLOGY

The HDZ series is designed to be used with maintenance free, sealed valve regulated lead acid batteries that provide a minimum emergency duration of 90 minutes. Recharge time of the battery is twenty-four (24) hours. Other batteries including Nickel-Cadmium are available, please contact Beghelli Customer Service for additional information.

MODEL RATING GUIDE

Model	Voltage	Wattage				Cabinet
		90min	120min	180min	240min	
HDZ-6-36	6	36	24	18	12	A
HDZ-6-54	6	54	36	27	18	A
HDZ-6-100	6	100	72	54	36	A
HDZ-12-36	12	36	27	18	12	A
HDZ-12-54	12	56	36	24	18	A
HDZ-12-100	12	100	72	54	36	A
HDZ-120-26	120	26	20	12	NA	A

WARRANTY

The HDZ Series comes with a 5-year factory warranty. Lamps are not covered under the warranty. Deliberate damage, misuse, improper installation effectively cancel the warranty.



PRODUCT OVERVIEW

The HDZ series offers emergency and EXIT illumination that is designed to perform in hazardous environments. The HDZ series is approved for installation in NEC Class I, Divisions 1 or 2, Groups C & D; or Class II, Divisions 1 or 2, Groups E, F and G areas. The HDZ series uses copper-free cast aluminum housings that offer trouble-free installation and durability.

EXTERNAL SPECIFICATIONS

The HDZ series housings are constructed from corrosion resistant, copper-free cast aluminum. The quick access thread on cover allows for trouble-free installation and reduces general maintenance time. A one-way stainless breather provides proper and effective unit ventilation. External test switch and monitor LED are standard. The HDZ series is capable of supporting remote emergency fixtures and exit signage.

INTERNAL SPECIFICATIONS

The HDZ series is configured with universal 120/277 VAC input with solid state charging circuitry. Standard features include low voltage disconnect, AC lockout and brownout protection.

INSTALLATION

The HDZ luminaire is suitable for surface wall or ceiling and pendant mounting. Suitable for installation and operation in NEC Class I, Div 1 or 2, Groups C & D; or Class II, Div 1 or 2, Groups E, F & G areas.

LAMP SELECTION

- 6V halogen: 8WH, 10WH, 12WH, 20WH
- 12V halogen: 8WH, 12WH, 20WH
- 24V halogen: 12WH, 20WH
- 120V compact: (CF) compact fluorescent: 2 x 13W

ORDERING INFORMATION

Series	Operation	Class	Div.	Groups	Light/EXIT	#of Lamps	Mounting	Options
HDZ-RMT(remote version)	6 (volt DC)	C1 (i)	D1 (i)	B	L1 (single head)	1 (single lamp)	CM (ceiling mount)	LED (120VAC LED exit lamp)
HDZ-E (exit version)	12 (volt DC)	C2 (ii)	D2 (ii)	C	X1 (single face exit)	2 (double lamp)	PM (pendant mount)	SW (special wording)
	24 (volt DC)							D
	120 (volt DC)	E					GL (green lens)	
		F						
				G				

HDZ BUILDER

Series	Operation	Class	Div.	Groups	Light/EXIT	#of Lamps	Mounting	Options	Options

EXAMPLE: HDZ-RMT12-C1-D2-CD-L1-2-WM

DESCRIPTION: HDZ hazardous area remote fixture, rated for class1 division 2, groups C&D, single head, double lamp, 12V, 12WH wall mount

EXAMPLE: HDZ-E-120-C1-D2CD-X1-1

DESCRIPTION: HDZ Hazardous area exit sign, rated for class1 and division2, groups C&D, single face, ceiling mount, complete with one 120V incandescent lamp.

JOB:	TYPE:
-------------	--------------

MECHANICAL SPECIFICATIONS

The HDZ Series housing is constructed from corrosion resistant, heavy duty cast aluminum. Exit sign face plates and frame are constructed from durable 20 gauge steel, standard with a white baked powder coat finish. Fixture mounting can be specified as either ceiling mount, wall mount or pendant mount. All lamp wiring is supplied pre-pulled, sealed and ready for input circuit connection. Exact dimensions and mounting arrangements will vary depending on the mounting configuration.

LAMP HEAD / FIXTURE FEATURES

The HDZ series offer a variety of lamp and fixture combinations. Each emergency lighting head can be configured with one or two fully adjustable lamp and reflector assemblies contained within the globe enclosure. Supported DC voltages of 6VDC, 12VDC or 24VDC utilize a wedge or bi-pin based incandescent lamp. 120VAC utilize a medium base lamp. Exit sign faceplate(s) and frame are constructed from durable 20 gauge steel, standard with a white baked powder coat finish. Custom exit colors and signage/graphics are also available.

INSTALLATION

The HDZ series of emergency lighting and exit fixtures are suitable for surface wall, surface ceiling and pendant mounting as specified. Suitable for various Class, Division and Group ratings as specified

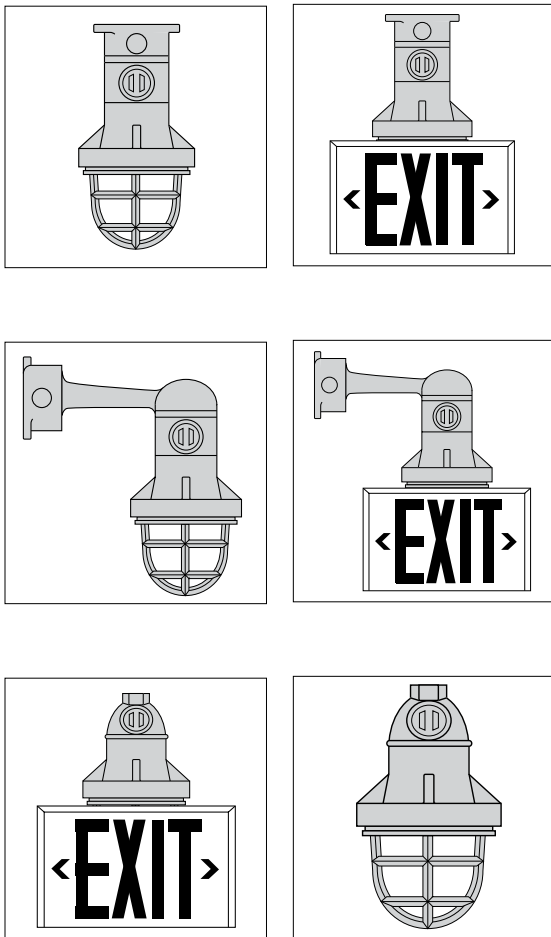

WARRANTY

The HDZ Series comes with a 5-year factory warranty. Lamps are not covered under the warranty. Deliberate damage, misuse, improper installation effectively cancel the warranty.















Joopu

Indoor Architectural Exits

SECTION FIVE



CONTENTS

	<p>VA4 Series</p> <p>Thermoplastic, LED Page</p> <p>Ceiling wall and end installed product specification. 76</p> <p>Technical Data 77</p>		<p>ATX Series</p> <p>Extruded Aluminum, LED Page</p> <p>Ceiling wall and end installed product specification. 90</p> <p>Technical Data 91</p>
	<p>VA5 Series</p> <p>Thermoplastic, LED, autotest Page</p> <p>Ceiling wall installed product specification. 78</p> <p>Technical Data 79</p>		<p>LC1 Series</p> <p>Di-Cast Aluminum, LED Page</p> <p>Ceiling wall and end installed product specification. 92</p> <p>Technical Data 93</p>
	<p>XCL Series</p> <p>Thermoplastic, LED Page</p> <p>Ceiling wall and end installed product specification. 80</p> <p>Technical Data 81</p>		<p>LC1-ECCO Series</p> <p>Di-Cast Aluminum, LED Page</p> <p>Ceiling wall and end installed product specification. (recessed or surface) 94</p> <p>Technical Data 95</p>
	<p>BBY-C Series</p> <p>Thermoplastic, LED Page</p> <p>Ceiling wall and end installed product specification. 82</p> <p>Technical Data 83</p>		<p>OL2 Series</p> <p>Steel construction, LED Page</p> <p>Ceiling wall and end installed product specification. 96</p> <p>Technical Data 97</p>
	<p>APE Series</p> <p>Thermoplastic, LED Page</p> <p>Ceiling wall installed product specification. 84</p> <p>Technical Data 85</p>		<p>OL2-TL Series</p> <p>Steel construction, LED Page</p> <p>Ceiling wall and end installed product specification. (recessed or surface) 98</p> <p>Technical Data 99</p>
	<p>STX Series</p> <p>Steel, LED Page</p> <p>Ceiling wall installed product specification. 86</p> <p>Technical Data 87</p>		<p>Cyclone Series</p> <p>Extruded Aluminum, LED Page</p> <p>Ceiling wall and end installed product specification. (surface only) 100</p> <p>Technical Data 101</p>
	<p>STX-C Series</p> <p>LED Page</p> <p>Ceiling wall and end installed product specification. 88</p> <p>Technical Data 89</p>		<p>Micra Series</p> <p>Extruded Aluminum, LED Page</p> <p>Ceiling wall and end installed product specification. 102</p> <p>Technical Data 103</p>



PRODUCT OVERVIEW

The VA4 series thermoplastic exit sign features an attractive low profile design. Ideal for commercial & institutional installations, the slim profile of this sign blends perfectly with current interior decors. The VA4 series uses high-output red or green LED technology. This truly “universal” exit sign, comes standard with two (2) stencils, one (1) backplate and a canopy. AC only and Self-Powered versions are available. The VA4 series meets Energy Star requirements.

INTERNAL SPECIFICATIONS

AC ONLY: standard 120/277VAC input

SELF-POWERED: standard 120/277VAC input, self-powered versions use sealed nickel-cadmium batteries to provide a minimum 90 minutes of emergency duration. Electronic cut-off circuit prevents overdischarge.

EXTERNAL SPECIFICATIONS

The VA4 series is constructed from durable corrosion and flame resistant thermoplastic. The VA4 series comes standard with a mounting canopy, two (2) stencils, one (1) backplate, removable chevrons and all mounting hardware. The VA4 series comes standard finished in white; optional black finish is available. A damp location rating is standard on all VA4 series products. An external LED status indicator and test switch is standard on all self-powered models.

INSTALLATION

The VA4 series exit is suitable for surface ceiling, wall and end mounting. Suitable for indoor and damp location installations.

ORDERING INFORMATION

Series	LED Color	Model	Options
VA4	R (red)	HT (AC only)	B (black housing)
	G (green)	SA (self powered)	

VA4 BUILDER

Series	LED Color	Model	Options

EXAMPLE: VA4-R-SA
 DESCRIPTION: VA4, thermoplastic exit, self-powered, red LED.

JOB:	TYPE:
-------------	--------------

MODERN DESIGN

The low profile design of the VA4 series exit provides a clean, attractive and affordable solution. The durable thermoplastic housing is corrosion and flame resistant. The VA4 series stencils include removeable chevrons that allow for easy “in the field” installation decisions. The modern and efficient design of the VA4 series allows for wall, ceiling or end mounting. Canopy and all installation hardware are included.

BATTERY TECHNOLOGY

The VA4 series is designed with a maintenance free, sealed Nickel-Cadmium battery providing a minimum emergency duration of 90 minutes. Recharge time of the battery is twenty-four (24) hours. The maximum battery working temperature is 50° C.

ELECTRICAL SPECIFICATIONS

The VA4 series is configured with high-output LED lamps. LED version is standard with 120/277VAC input.

- RED LED - 4 Watts
- GREEN LED - 2 Watts

MECHANICAL SPECIFICATIONS

The VA4 series is constructed of durable corrosion and flame resistant thermoplastic. Field removeable directional chevron arrows are standard. The VA4 series can be universally mounted single or double face. Canopy and mounting hardware are included. High-output LED technology provides energy savings, long life and even illumination levels. 120/277VAC input, maintenance free, sealed Nickel Cadmium batteries are protected by an electronic cut-off circuit that prevents overdischarge. External test switch and monitor LED are standard on SA versions.

SELF-POWERED VERSIONS

The VA4-SA self-powered series is designed to operate on battery power in the event of a regular / mains power failure. Both the battery and charger are completely contained within the standard enclosure. There are no external components and no alterations made to the external dimensions of the standard sign. The VA4-SA self-powered series utilize a solid state transformer technology that eliminates the possibility of relay failure due to particle build up on the relay. Status is easily determined via an LED that indicates AC-ON. A push button test switch allows maintenance personnel to quickly confirm the operational status of the exit on AC fail.

DIMENSIONS (in.)

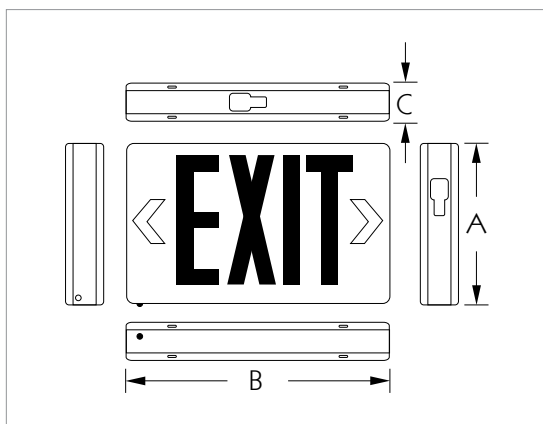

Series	A"	B"	C"
VA4	7.5"	12"	1.5"

WARRANTY

The VA4 series comes with a 5-year factory warranty. Deliberate damage, misuse, improper installation effectively cancel the warranty.



INTERNAL SPECIFICATIONS

AC ONLY: standard 120/277VAC input

SELF-POWERED: standard 120/277VAC input, self-powered versions use sealed nickel-cadmium batteries to provide a minimum 90 minutes of emergency duration. Electronic cut-off circuit prevents overdischarge.

EXTERNAL SPECIFICATIONS

The VA5 series is constructed from high-quality thermoplastic that is corrosion and flame resistant. The VA5 series includes as standard equipment, a mounting canopy, two (2) stencil faces, one (1) backplate, field adjustable chevrons and all mounting hardware. Available in a white finish only. Damp location is standard on all VA5 series products. An external LED status indicator and test switch are standard on all self-powered models.

PRODUCT OVERVIEW

The VA5 series is part of the ever growing family of innovative, yet economical thermoplastic exit signs. The slim profile, damp location rating and easy installation make the VA5 ideal for commercial, institutional & public projects.

An easy to specify universal sign, the VA5 includes two (2) stencils, one (1) backplate, field adjustable chevrons, canopy and all mounting hardware. Available in Self-powered and AC only configurations. High-output red or green LED's. The VA5 meets energy star requirements.

BATTERY TECHNOLOGY

The VA5-SA series uses an internal maintenance-free, sealed nickel-cadmium battery that provides a minimum emergency duration of ninety (90) minutes. Complete recharge time of the battery is twenty-four (24) hours. The maximum working temperature is 50°C.

INSTALLATION

The VA5 series exit is suitable for surface ceiling, wall and end mounting. Suitable for indoor & damp location installations.

ORDERING INFORMATION

Series	LED Color	Model	Diagnostics	Options
VA5	R (red)	HT (AC only)	ATX (Auto test)	IRT (infrared remote test)
	G (green)	SA (self powered)		B (black housing)
Note: SA version only				FAI (fire alarm interface)

VA5 BUILDER

Series	LED Color	Model	Diagnostics	Options

EXAMPLE: VA5R-SA-AT
 DESCRIPTION: VA5, thermoplastic exit, red LED, self-powered, white finish, auto-test

JOB:	TYPE:
-------------	--------------

AUTO-TEST DIAGNOSTICS

The VA5 series comes standard with the Beghelli AutotesT diagnostic system. Featuring continuous monitoring of the units main components (battery, charger, transformer, lamps & LED's) and providing instant visual verification of the status.

AUTO-TEST FEATURES:

- Monitor battery disconnection, charger failure, LED failure and transformer fault every 5 seconds without discharging the battery.
- Automatically indicates lamp, battery and charger status by dual-color LED lamp.
- Factory preset AutotesT does not need to be field adjusted or reset for proper operation

AUTO-TEST FUNCTIONS:

- Verifies battery disconnect, charger board failure, LED failure and transformer failure every 5 seconds.
- One (1) minute autotest every month.
- Thirty (30) minute autotest every six (6) months.
- Ninety (90) minute autotest every twelve (12) months.

AUTOTEST VISUAL ALERT

- (1) blink red LED = Battery not connected
- (2) blinks red LED = Battery shorted and/or Battery voltage drop
- (3) blinks red LED = Charger board fault
- (4) blinks red LED = Transformer fault
- (5) blinks red LED = N/A
- (6) blinks red LED = N/A
- (7) blinks red LED = LED lamp fault

AUTOTEST MANUAL FUNCTIONS:

- Press test button 1x (within 2 sec.) = 1 minute test
- Press test button 2x (within 2 sec.) = 5 minute test
- Press test button 3x (within 2 sec.) = 30 minute test
- Press test button 4x (within 2 sec.) = 90 minute test

MECHANICAL SPECIFICATIONS

The VA5 series is constructed from high-quality corrosion and flame resistant thermoplastic. Field adjustable chevrons are standard on all VA5 exits. The VA5 can be universally mounted configured for either single or double face installations. Canopy and mounting hardware is included. High-output red or green LED's provide energy savings, long life and create even illumination across the stencil face. 120/277VAC input is standard on all VA5 series exits. The (SA) version features maintenance-free nickel-cadmium batteries, electronic cut-off that prevents overdischarge and the Beghelli AutotesT diagnostic system.

SELF-POWERED (SA) VERSION

The VA5-SA has been designed to be an "always on" exit. Operating under normal AC until there is a power failure and then automatically switching to the DC emergency mode. Both the battery and charger are fully contained within the standard enclosure. There are no external components that add to the dimensions of the product. This results in a clean and simple design. The VA5-SA utilizes solid state transformer technology that eliminates the possibility of relay failure. Status of the VA5 is displayed via an LED that indicates AC-ON and all functions of the AutotesT diagnostic system. An external test switch allows inspectors & maintenance personnel to quickly confirm the operations status of the VA5 exit. Optional infrared testing (IRT) allows wireless testing of all functions.

INFRARED TESTING OPTION

The VA5 series offers an optional infrared testing (IRT) option. Using the compact remote, inspectors and maintenance personnel are able to access all functions of the VA5 series and perform the required tests. Not only is this convenient when testing hard to access exit signs, it is also a much safer way. Climbing and moving ladders from installation to installation is time consuming and can be dangerous. The infrared testing option performs all available tests with the press of a button.

DIMENSIONS (in.)

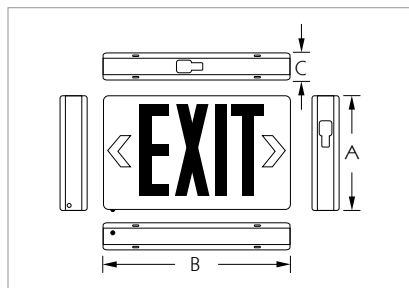

Series	A"	B"	C"
VA5	8.5"	12"	1.75"

WARRANTY

The VA5 series comes with a 5-year factory warranty. Deliberate damage, misuse, improper installation effectively cancel the warranty.



PRODUCT OVERVIEW

The XCL series combination exit & emergency unit features an attractive, contemporary thermoplastic housing design. Ideal for commercial and institutional installations, the XCL series combination unit blends perfectly with current interior decors. The XCL series uses high-output red or green LED technology. Universal mounting on the wall or ceiling allows installation versatility. Emergency lighting heads can be swiveled 360° providing effective and accurate emergency illumination.

INTERNAL SPECIFICATIONS

SELF-POWERED: standard 120/277VAC input, self-powered versions use a maintenance-free sealed lead acid battery that provides a minimum 90 minutes of emergency duration. Solid state charger and transfer.

EXTERNAL SPECIFICATIONS

The XCL series is constructed from durable corrosion and flame resistant thermoplastic. The XCL series comes standard with a mounting canopy, two (2) stencils, one (1) backplate, removeable chevrons and all mounting hardware. Side mounted emergency lighting heads rotate 360° providing a new level of adjustability. The XCL series comes standard finished in white; optional black finish is available. Removeable chevron arrows are standard on each fixture. External LED status indicator and test switch are standard.

INSTALLATION

The XCL series combination unit is suitable for surface ceiling, and wall mounting. Suitable for indoor and damp location installations

ORDERING INFORMATION

Series	LED	Face/Mounting	Housing	Options
XCL	R (red)	U (universal)	W (White)	R (remote capable)
	G (green)		B (black)	NH (no heads)
				NHR (no heads, remote)

XCL BUILDER

Series	LED	Face/Mounting	Housing	Options

EXAMPLE: XCL-RU-W
 DESCRIPTION: XCL, thermoplastic combination unit, red LED, universal face, universal mounting, white finish.

JOB:	TYPE:
-------------	--------------

MODERN DESIGN

The **XCL** series combination exit & emergency unit provides an attractive, versatile, space saving and affordable solution. The durable thermoplastic housing is corrosion and flame resistant. The **XCL** series stencils include removeable chevrons that allow for easy “in the field” installation decisions. The modern and efficient design of the **XCL** series allows for surface ceiling, and wall mounting. Canopy and all installation hardware is included.

ELECTRICAL SPECIFICATIONS

The **XCL** series is configured with high-output LED lamps. LED version is standard with 120/277VAC input. Emergency lighting heads come standard configured with 5.4 watt incandescent wedge base lamps.

- RED LED - 4 Watts
- GREEN LED - 2 Watts

BATTERY TECHNOLOGY

The **XCL** series is designed with a 6V 4.5Ah maintenance free, sealed lead acid battery that provides a minimum emergency duration of 90 minutes. Recharge time of the battery is twenty-four (24) hours. The maximum battery working temperature is 50° C. When the **XCL** is ordered with the “remote capable” option, a larger 6V 7Ah battery is used.

MECHANICAL SPECIFICATIONS

The **XCL** series is constructed of durable corrosion and flame resistant thermoplastic. Field removeable directional chevron arrows are standard. The **XCL** series can be universally mounted single or double face. Canopy and mounting hardware are included. High-output LED technology provides energy savings, long life and even illumination levels. Side mounted emergency heads rotate 360°, providing accurate emergency illumination. 120/277VAC input, maintenance free sealed lead acid battery is protected by an electronic cut-off circuit that prevents overdischarge. External test switch and monitor LED are standard.

SELF-POWERED VERSIONS

The **XCL** self-powered series is designed to operate on battery power in the event of a regular / mains power failure. Both the battery and charger are completely contained within the standard enclosure. There are no external components and no alterations made to the external dimensions of the standard sign. The **XCL** self-powered series utilize a solid state transformer technology that eliminates the possibility of relay failure due to particle build up on the relay. Status is easily determined via an LED that indicates AC-ON. A push button test switch allows maintenance personnel to quickly confirm the operational status of the exit on AC fail.

DIMENSIONS (in.)

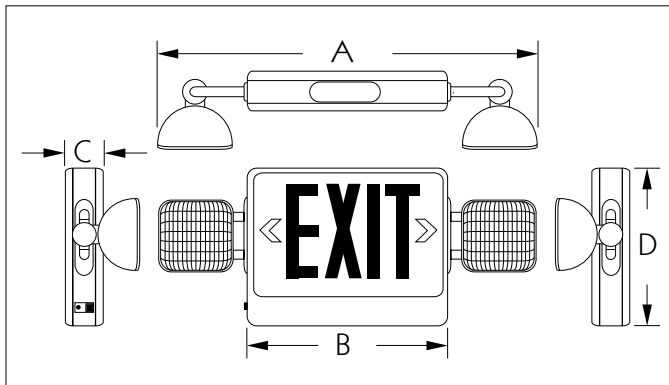

Series	A"	B"	C"	D"
XCL	22"	13"	2.8"	10"

WARRANTY

The **XCL** Series comes with a 5-year factory warranty. Lamps are not covered under the warranty. Deliberate damage, misuse, improper installation effectively cancel the warranty.



PRODUCT OVERVIEW

The BBY-C series combination exit & emergency unit is the newest evolution in affordable thermoplastic emergency luminaires. The BBY-C series offers a new level of design and technology. The injection molded thermoplastic housing is corrosion and flame resistant and features an innovative snap together design allowing fast and easy installation. The BBY-C features high-output LED's that evenly illuminate the exit. The top mounted emergency unit incorporates 5W halogen MR-16 lamps that are fully adjustable. The BBY-C comes standard finished in white.

INTERNAL SPECIFICATIONS

SELF-POWERED: standard 120/277VAC input, self-powered versions use a maintenance-free 6V 4.5Ah sealed lead acid battery that provides a minimum 90 minutes of emergency duration. Solid state charger and transfer.

EXTERNAL SPECIFICATIONS

The BBY-C series is constructed from high quality corrosion and flame resistant thermoplastic. White finish is standard. The BBY combination series features a low profile exit and a top mounted emergency light. The exit sign has field adjustable chevrons and snap together face panels. The top mounted emergency unit features semi-recessed MR-16 lighting heads that are positioned in 360 gimbal style assemblies. Universal mounting bracket for wall or ceiling installations. External test switch and monitor LED are standard.

INSTALLATION

The BBY-C series combination unit is suitable for surface ceiling, wall and end mounting. Suitable for indoor and damp location installations.

ORDERING INFORMATION

Series	LED	Face/Mounting	Housing
BBY-C	LR (red) LG (green)	U (universal)	W (White)

BBY-C BUILDER

Series	LED	Face/Mounting	Housing

EXAMPLE: BBY-C-LR-U-W
DESCRIPTION: BBY, thermoplastic combination unit, red LED, universal face, white finish.

JOB:	TYPE:
-------------	--------------

HOUSING

The **BBY-C** series utilizes a corrosion and flame resistant injection molded thermoplastic housing and mounting bracket. The innovative snap together design allows fast and effortless installation. The **BBY-C** series is ideal for use in areas where materials such as steel and aluminum may deteriorate. The universal mounting pattern allows wall, ceiling or end installations.

ELECTRICAL SPECIFICATIONS

The **BBY-C** series combination luminaires are configured for standard operation 120/277VAC dual voltage input with current limit protection. Minimum 90 minutes emergency duration. Twenty-four (24) hour recharge time.

BATTERY TECHNOLOGY

The **BBY-C** series is supplied with a sealed, maintenance-free, valve regulated 6V 4.5Ah lead calcium battery that provides a minimum emergency duration of 90 minutes. Recharge time of the battery is twenty-four (24) hours. The maximum working temperature is 50° C

MECHANICAL SPECIFICATIONS

The **BBY-C** series is constructed of durable corrosion and flame resistant thermoplastic. Field removeable directional chevron arrows are standard. The **BBY-C** series can be universally mounted single or double face. Canopy and mounting hardware are included. High-output LED technology provides energy savings, long life and even illumination levels. Top mounted emergency heads, provide accurate emergency illumination. 120/277VAC input, maintenance free sealed lead calcium battery is protected by an electronic cut-off circuit that prevents overdischarge. External test switch and monitor LED are standard

LAMP HEAD FEATURES

The **BBY-C** series is supplied with two (2) semi-recessed, front mounted 5W MR-16 lamps. Lamp heads are mounted within a gimbal style assembly, which allows correct and accurate beam positioning.

MR-16 TECHNOLOGY

The **BBY-C** series luminaire benefits from the use of MR-16 lamp technology. Offering superior light output, compact design, high efficiency and architectural appeal, the MR-16 lamps are an intelligent light choice. The **BBY-C** series comes standard with 2x5W halogen MR-16 lamps.

DIMENSIONS (in.)

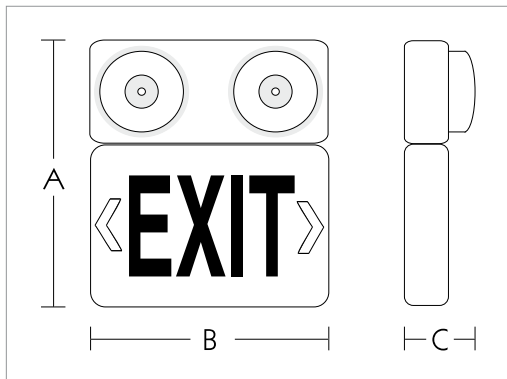

Series	A"	B"	C"	D"
BBY-C	14.2"	12.2"	4.2"	5.5"

WARRANTY

The **BBY-C** Series comes with a 5-year factory warranty. Lamps are not covered under the warranty. Deliberate damage, misuse, or improper installation effectively cancel the warranty.



PRODUCT OVERVIEW

The APE series combination exit & emergency unit offers the ultimate in flexibility. Emergency lighting heads can be rotated from a side-mount configuration to a top-mount configuration in one simple motion. Included as standard equipment is the Beghelli Autotest, which provides instant visual verification of the operating status. The APE series features a durable and contemporary thermoplastic housing. Red or green high efficiency, high-brightness LED's are standard. Universal mounting on the wall or ceiling allows installation versatility. The APE is ideal for commercial and institutional installations.

INTERNAL SPECIFICATIONS

SELF-POWERED: Standard 120/277VAC input, 6V 4.5Ah sealed lead calcium battery provides minimum 90 minutes emergency duration.

AUTOTEST: integrated diagnostics that monitor and indicate battery disconnect, charger failure, lamp failure & transformer fault.

EXTERNAL SPECIFICATIONS

The APE series is constructed from durable corrosion and flame resistant thermoplastic. Offered standard as a "universal" unit, the APE includes a mounting canopy, two (2) stencil faces and a backplate. Removeable chevrons and mounting hardware is included. Emergency heads can be rotated from side mount to top mount and are fully adjustable for accurate emergency illumination. The APE comes standard with a white finish. Removeable chevron arrows allow field adjustability. External test switch and monitor LED are standard

INFRARED TESTING OPTION

The APE series offers an optional infrared testing (IRT) option. Using the compact remote, inspectors and maintenance personnel are able to access all functions of the APE series and perform the required tests. Not only is this convenient when testing hard to access exit signs, it is also a much safer way. Climbing and moving ladders from installation to installation is time consuming and can be dangerous. The infrared testing option performs all available tests with the press of a button.

INSTALLATION

The APE series combination unit is suitable for surface ceiling, wall and pendant mounting. Suitable for indoor & damp location installations.

ORDERING INFORMATION

Series	LED	Face/Mounting	Housing	Diagnostics	Options
APE	R (red)	U (universal)	W (White)	AT (auto-test)	R (remote capable)
	G (green)		B (black)		IRT (infrared remote test)

Note (a): The Autotest diagnostic feature is standard on the APE series.

Note (b): IRT option includes handheld remote.

APE BUILDER

Series	LED	Face/Mounting	Housing	Diagnostics	Options

EXAMPLE: APE-GU-B-AT

DESCRIPTION: APE, thermoplastic combination unit, green LED, universal face, universal mounting, black finish, autotest diagnostics.

JOB:	TYPE:
-------------	--------------

AUTO-TEST DIAGNOSTICS

The APE series comes standard with the Beghelli AutotestT diagnostic system. Featuring continuous monitoring of the units main components (battery, charger, transformer, lamps & LED's) and providing instant visual verification of the status.

AUTO-TEST FEATURES:

- Monitor battery disconnection, charger failure, lamp failure, LED failure and transformer fault every 5 seconds without discharging the battery.
- Automatically indicates lamp, battery and charger status by dual-color LED lamp.
- Factory preset AutotestT does not need to be field adjusted or reset for proper operation.

AUTO-TEST FUNCTIONS:

- Verifies battery disconnect, charger board failure, lamp failure, LED failure and transformer failure every 5 seconds.
- One (1) minute autotest every month.
- Thirty (30) minute autotest every six (6) months.
- Ninety (90) minute autotest every twelve (12) months.

AUTOTEST VISUAL ALERT

- (1) blink red LED = Battery not connected
- (2) blinks red LED = Battery shorted and/or Battery voltage drop
- (3) blinks red LED = Charger board fault
- (4) blinks red LED = Transformer fault
- (5) blinks red LED = Emergency lamp fault
- (6) blinks red LED = Remote lamp fault
- (7) blinks red LED = LED lamp fault

AUTOTEST MANUAL FUNCTIONS:

- Press test button 1x (within 2 sec.) = 1 minute test
- Press test button 2x (within 2 sec.) = 5 minute test
- Press test button 3x (within 2 sec.) = 30 minute test
- Press test button 4x (within 2 sec.) = 90 minute test

DIMENSIONS (in.)

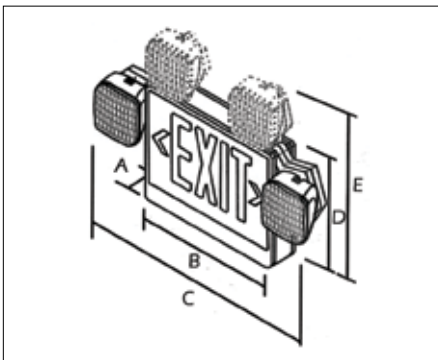

Series	A"	B"	C"	D"	E"
APE	2.5"	16"	21"	10"	15"

MODERN DESIGN / ADJUSTABLE HEADS

The APE series combination exit & emergency unit features the ultimate in adjustability. Universal mounting, field adjustable chevrons and emergency lighting heads that swivel from a side mount configuration to a top mount configuration make the APE the most flexible unit in the field. Canopy and mounting hardware is also included.

MECHANICAL SPECIFICATIONS

The APE series housing uses durable corrosion and flame resistant thermoplastic. The APE can be universally mounted single or double face. High-efficiency, high-brightness LED's provide energy savings, long life and even illumination. Emergency lighting heads can be swiveled from side-mount to top-mount and anywhere in between. 5.4W Tungstem lamps are standard and included. Lens material is a high-impact polystyrene.

BATTERY

The APE series features a maintenance-free sealed lead calcium battery (6V 4.5Ah) that provides the APE with a minimum emergency operating time of 90 minutes. The APE can be ordered with an additional 6V 4.5Ah battery for remote loads up to twelve (12) additional watts. The maximum operating temperature is 50° c.

SUITABLE FOR DAMP LOCATION

The APE series is rated for use in damp locations. The APE is ideal for use in exterior covered breezeways, warehouses, covered corridors, pool areas and high humidity regions.

INSTALLATION MADE EASY

The APE series can be wall mounted or canopy mounted (ceiling). The canopy securely snaps in place without the use of any tool. Supplied with all the required standard mounting hardware and easy field wiring, the APE series is a favorite among installers.

WARRANTY

The APE Series comes with a 5-year factory warranty. Lamps are not covered under the warranty. Deliberate damage, misuse, improper installation effectively cancel the warranty.



PRODUCT OVERVIEW

The **STX** series of commercial exit signs feature an attractive, contemporary steel housing design. Ideal for commercial and institutional installations, the slim profile of this sign blends perfectly with current interior decors. The **STX** comes standard configured with high-output LED technology. Available in both AC only and Self-powered versions.

INTERNAL SPECIFICATIONS

AC ONLY: standard 120/277VAC input

SELF-POWERED: standard self-powered versions use sealed nickel-cadmium batteries to provide a minimum 90 minutes of emergency duration. Optional 120 minute duration battery is available. Solid state charger and transfer.

EXTERNAL SPECIFICATIONS

The **STX** series is constructed from durable 20 gauge steel. The **STX** comes standard with a white baked powder coat finish. Available in custom epoxy-based powder coat finishes (please specify). Single, double or universal face versions must be specified. Universal mounting pattern and key hole slots are stamped into the back plate. Removeable chevron arrows are standard on each fixture. The self-powered version comes standard with an external LED status indicator and test switch

INSTALLATION

The **STX** exit is suitable for surface ceiling, wall and end mounting, Pendant mount is also available. Suitable for indoor installations.

ORDERING INFORMATION

Series	Model	LED	Face No.	Housing	Options
STX	HT (AC only)	LR (red)	1 (single)	W (white)	AT (auto-test)
	SA (self-powered)	LG (green)	2 (double)	B (black)	FL (visual alarm-specify voltage)
			U (universal)		BZ (audible alarm - specify)
					CC (custom color)
					FAI (fire alarm interface)

STX BUILDER

Series	Model	LED	Face No.	Housing	Options

EXAMPLE: STX-HT-LRU-W-AT
 DESCRIPTION: STX, steel exit, AC only, red LED, universal face, white housing, auto-test.

JOB:	TYPE:
-------------	--------------

MODERN DESIGN

The modern and thin design of the **STX** series exit provides a clean and attractive appearance. The 20 gauge steel frame contains no external holes or slots adding to the clean look while eliminating unwanted light leaks. The 20 gauge steel forms a rigid and durable frame that can be securely mounted in any application. The face and back plates are mounted into the frame using a channel system that permits simple and speedy removal during installation

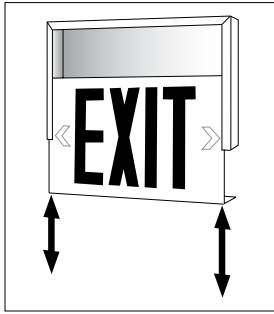

Faceplate slides out for quick and easy installation.

ELECTRICAL SPECIFICATIONS

The **STX** series is configured with high-output LED lamps. LED is standard with 120/277VAC input. All LED versions consume only 1.1W nominal power. Optional emergency illumination is provided by the LED light source at the following wattages:

- 6VDC - 0.5 Watts
- 12VDC - 1.5 Watts
- 24VDC - 3.5 Watts

MECHANICAL SPECIFICATIONS

The **STX** is constructed of durable 20 gauge steel. Universal mounting pattern and key hole slots are stamped on the back plate. Surface mount conduit entry knockouts are also provided. Field removeable directional chevron arrows are standard. The **STX** is supplied standard with an attractive and durable white, baked powder coat finish. Other colors are available, including custom color matching, please specify. The advanced design of the **STX** leaves it with no extraneous holes or slots, thereby eliminating unwanted light leaks. A simple and sturdy channel design securely holds the face and back plates into the frame providing quick and trouble-free field installations

SELF-POWERED VERSIONS

The **STX-SA** self-powered series is designed to operate on battery power in the event of a regular / mains power failure. Both the battery and charger are completely contained within the standard enclosure. There are no external components and no alterations made to the external dimensions of the standard sign. The **STX-SA** self-powered series utilize a solid state transformer technology that eliminates the possibility of relay failure due to particle build up on the relay. Status is easily determined via an LED that indicates AC-ON. A push button test switch allows maintenance personnel to quickly confirm the operational status of the exit on AC fail.

BATTERY TECHNOLOGY

The **STX-SA** is designed with a maintenance free, sealed Nickel-Cadmium battery providing a minimum emergency duration of 90 minutes. An optional 120 minute Nickel-Cadmium battery is available. Recharge time of the battery is twenty-four (24) hours. The maximum battery working temperature is 50° C.

DIMENSIONS (in.)

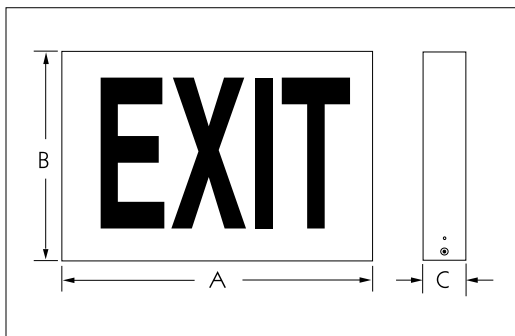

Series	A"	B"	C"
STX	12"	7.5"	2.25"

WARRANTY

The **STX** Series comes with a 5-year factory warranty. Lamps are not covered under the warranty. Deliberate damage, misuse, improper installation effectively cancel the warranty.

CHARGER SPECIFICATIONS

The **STX-C** (combination) series charger is a fully automatic current limited charger with solid state line latched low voltage disconnect protection. All components are temperature compensated. The charger also has brownout and short circuit protection. Charger status is determined via a dual diagnostic LED display that indicates AC ON and High Charge. A push button test switch allows maintenance personnel to quickly determine the status of the exit and lamp load on AC fail.

ELECTRICAL SPECIFICATIONS

The **STX** combination series is configured with high-output LED lamps. Standard with 120/277VAC input. All LED versions use only 1.1W nominal power. Emergency illumination is provided by the LED light source at the following wattages:

- 6VDC - 1.5 Watts
- 12VDC - 2.5 Watts
- 24VDC - 4.5 Watts

MECHANICAL SPECIFICATIONS

The **STX-C** series is constructed of durable 20 gauge steel. Universal mounting pattern and key hole slots are stamped on the back plate. Surface mount conduit entry knockouts are also provided. Field removable directional arrows are standard. This versatile fixture is supplied standard with an attractive and durable white, powder coat finish. Other colors are available, including custom color matching (please specify). The advanced design of the **STX-C** series contains no extraneous holes or slots, thereby eliminating unwanted light leaks. A simple and sturdy channel design securely holds the face and back plates into the frame providing quick and trouble free installation and maintenance.

MODEL RATING GUIDE

The **STX-C** series provides exceptional emergency lighting versatility by combining an exit sign with a lighting unit. The various voltage and wattage configurations of the **STX-C** series allows for the powering of remote emergency lighting fixtures, further enhancing the capabilities of this series. The clean looks and sturdy design work well in just about every application.

BATTERY TECHNOLOGY

The **STX-C** series is designed with a maintenance free, valve regulated sealed lead-acid battery providing emergency lighting duration as specified per unit. Recharge time of the battery is twenty-four (24) hours. The maximum battery operating temperature is 50° C.

HEAD FEATURES

The **STX-C** series is supplied with either (2) PAR18 small style heads or large style PAR36 heads. Both head styles are constructed of high impact thermoplastic in a color matching the finish of the cabinet. Both feature a unique twist locking collar that securely holds the lens and facilitates quick and easy re-lamping.

DIMENSIONS (in.)

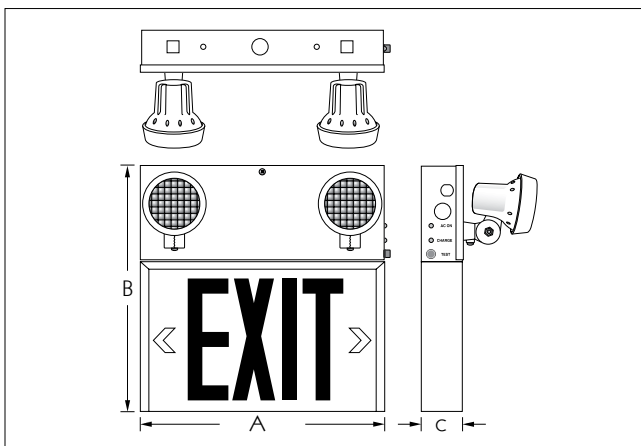

Series	A"	B"	C"	D"
STX-C	12"	12.5"	2.25"	4.7"

WARRANTY

The **STX-C** Series comes with a 5-year factory warranty. Lamps are not covered under the warranty. Deliberate damage, misuse, improper installation effectively cancel the warranty.



PRODUCT OVERVIEW

The **ATX** series of commercial extruded aluminum exit signs feature an attractive and slim housing design. Ideal for commercial and institutional installations, the slim profile of this extruded fixture blends perfectly with current interior decors. The **ATX** series is available configured with high-output LED's in AC only and Self-Powered operation versions.

INTERNAL SPECIFICATIONS

AC ONLY: comes standard configured with high-output LED technology, 120/277VAC input.

SELF-POWERED: comes standard configured with high-output LED technology, 120/277VAC input. Nickel-cadmium batteries provide a minimum 90 minutes of emergency duration. Optional 120 minute duration battery is available. Solid state charger & transfer.

EXTERNAL SPECIFICATIONS

The **ATX** series is constructed from durable extruded Aluminum. Standard with a white baked powder coat finish. The **ATX** is also available in custom epoxy-based powder coat finishes (please specify). Single, double or universal face version must be specified. Universal mounting pattern and key hole slots are stamped into the back plate. Removable chevron arrows are standard on each fixture. The self-powered version comes standard with an external LED status indicator and test switch.

INSTALLATION

The **ATX** is suitable for surface, ceiling, wall, end and pendant mounting. Suitable for indoor installations

ORDERING INFORMATION

Series	Model	LED	Face No.	Housing	Options
ATX	HT (AC only)	LR (red)	1 (single)	W (white)	AT (auto-test)
	SA (self-powered)	LG (green)	2 (double)	B (black)	FL (visual alarm - specify voltage)
			U (universal)		BZ (audible alarm - specify voltage)
					CC (custom color - specify)
					SW (special wording - specify)
					2CK (dual-circuit)
					PK (pendant kit - specify)
					120SA (120 minute emergency)
					FAI (fire alarm interface)
					BA (brushed aluminum)

ATX BUILDER

Series	Model	LED	Face No.	Housing	Options

EXAMPLE: ATX-SA-LRU-W
 DESCRIPTION: ATX extruded aluminum exit, self-powered unit, red LED, universal face, white housing.

JOB:	TYPE:
-------------	--------------

EXTRUDED DESIGN

The clean lines and thin design of the ATX series exit provides it with a modern and attractive appearance. The extruded aluminum frame contains no external holes or slots adding to the clean look while eliminating unwanted light leaks. The aluminum also forms a rigid and durable frame that can be securely mounted in any application. The face and back plates are mounted into the frame using a pin and channel system that permits simple and speedy removal during installation. This design also eliminates the need for any visible screws or fasteners.

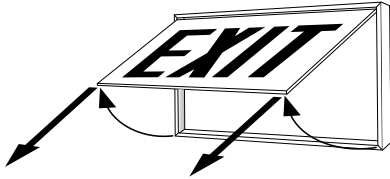

Faceplate slides up and outwards for quick and easy installation.

ELECTRICAL SPECIFICATIONS

The ATX series is configured with high-output LED lamps. Standard with 120/277VAC input. All LED versions consume only 1.1W nominal power. Optional emergency illumination is provided by the LED light source at the following wattages:

- 6VDC - 0.5 Watts
- 12VDC - 1.5 Watts
- 24VDC - 3.5 Watts

MECHANICAL SPECIFICATIONS

The ATX is constructed of sturdy extruded aluminum. Universal mounting pattern and key hole slots are stamped on the back plate. Surface mount conduit entry knockouts are also provided. Field removable directional chevron arrows are standard. The ATX is supplied standard with an attractive and durable white, baked powder coat finish. Other colors are available, including custom color matching, please specify. The face plate is held securely in place with a pin and channel system that allows the face plate to slide in the frame providing complete access to the interior of the sign. No visible screws, nuts or fasteners are used that would detract from the clean, modern design.

SELF-POWERED VERSIONS

The ATX-SA self-powered series is designed to operate on battery power in the event of a regular / mains power failure. Both the battery and charger are completely contained within the standard enclosure. There are no external components and no alterations made to the external dimensions of the standard sign. The ATX-SA self-powered series utilize a solid state transformer technology that eliminates the possibility of relay failure due to particle build up on the relay. Status is easily determined via an LED that indicates AC-ON. A push button test switch allows maintenance personnel to quickly confirm the operational status of the exit on AC fail

BATTERY TECHNOLOGY

The ATX-SA is designed with a maintenance free, Nickel-Cadmium battery providing a minimum emergency duration of 90 minutes. An operational 120 minute Ni-Cad battery is available. Recharge time of the battery is twenty-four (24) hours. The maximum battery working temperature is 50° C.

DIMENSIONS (in.)

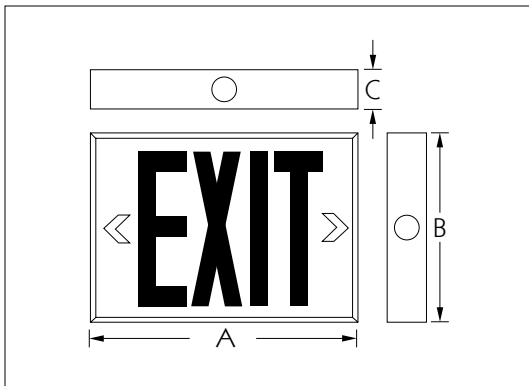

Wattage	A"	B"	C"
2x8W	17"	6 1/2"	4"

WARRANTY

The ATX Series comes with a 5-year factory warranty. Deliberate damage, misuse, improper installation effectively cancel the warranty.



PRODUCT OVERVIEW

The **LC1** series is designed to provide a durable, traditional and maintenance-free exit sign. The **LC1** is manufactured from sturdy die-cast aluminum and comes standard with a brushed aluminum face and black housing. A universal mounting canopy is also included for ceiling and end mount applications. The **LC1** series comes standard configured with high-output LED technology. AC only and Self-powered versions are available.

INTERNAL SPECIFICATIONS

AC ONLY: comes standard configured with high-output LED technology, 120/277VAC input.

SELF-POWERED: comes standard configured with high-output LED technology, 120/277VAC input. Nickel-cadmium batteries provide a minimum 90 minutes of emergency duration. Optional 120 minute duration battery is available. Solid state charger & transfer.

EXTERNAL SPECIFICATIONS

The **LC1** series is constructed from durable die-cast aluminum and comes standard with a brushed aluminum face plate(s) and a black housing. Single or double face versions must be specified. Available in custom epoxy-based powder coat finishes (please specify). Universal mounting pattern and key hole slots are stamped into the housing. Removable chevron arrows are standard on each unit. The self-powered LED version comes standard with an external LED status indicator and test switch.

INSTALLATION

The **LC1** series is suitable for ceiling, wall and end mounting. Suitable for indoor installations.

ORDERING INFORMATION

Series	Model	LED	Face No.	Housing	Options
LC1	HT (AC only)	LR (red)	1 (single)	W (white)	AT (auto-test)
	SA (self-powered)	LG (green)	2 (double)	B (black)	FL (visual alarm - specify voltage)
				AL (aluminum)	BZ (audible alarm - specify voltage)
					TPS (tamper proof shield & screws)
					SW (special wording - specify)
					2CK (dual-circuit)
					PK (pendant kit - specify)
					120SA (120 minute emergency)
					FAI (fire alarm interface)

LC1 BUILDER

Series	Model	LED	Face No.	Housing	Options

EXAMPLE: LC1-HT-LG1-B-AL
 DESCRIPTION: LC1 die-cast exit, AC only, green LED, single face, black housing, brushed aluminum stencil.

JOB:	TYPE:
-------------	--------------

DIE-CAST DESIGN

The excellent visual performance and architecturally pleasing design makes the LC1 series the premier choice for applications requiring the durability and the craftsmanship of die-cast aluminum exit signs. The standard brushed aluminum face blends well with any setting and provides a clean, modern look. The die-cast aluminum construction provides the LC1 series with exceptional strength and rigidity.

ELECTRICAL SPECIFICATIONS

The LC1 series is configured with high-output LED lamps. Standard with 120/277VAC input. All LED versions consume only 1.1W nominal power. Optional emergency illumination is provided by the LED light source at the following wattages:

- 6VDC - 0.5 Watts
- 12VDC - 1.5 Watts
- 24VDC - 3.5 Watts

MECHANICAL SPECIFICATIONS

The LC1 series is constructed from durable die-cast aluminum. Universal mounting pattern and key hole slots are stamped on the back. A surface mount conduit entry knockout is also provided. Field removable directional chevron arrows are standard. The LC1 is supplied standard with a brushed aluminum face(s) and a black baked powder coat finished housing. Other colors are available, including custom color matching, please specify. The face plate is held securely in place with four reinforcement clips, that allow for complete access to the interior of the sign. No visible screws, nuts or fasteners are used in the face plate design.

SELF POWERED VERSIONS

The LC1-SA series is designed to operate on battery power in the event of a regular / mains power failure. Both the battery and charger are completely contained within the standard enclosure. There are no external components and no alterations made to the external dimensions of the standard sign. The LC1-SA self-powered series utilize a solid state transformer technology that eliminates the possibility of relay failure due to particle build up on the relay. Status is easily determined via an LED that indicates AC-ON. A push button test switch allows maintenance personnel to quickly confirm the operational status of the exit on AC fail.

BATTERY TECHNOLOGY

The LC1-SA is designed with a maintenance free, Nickel-Cadmium battery providing a minimum emergency duration of 90 minutes. An operational 120 minute Ni-Cad battery is available. Recharge time of the battery is twenty-four (24) hours. The maximum battery working temperature is 50° C.

DIMENSIONS (in.)

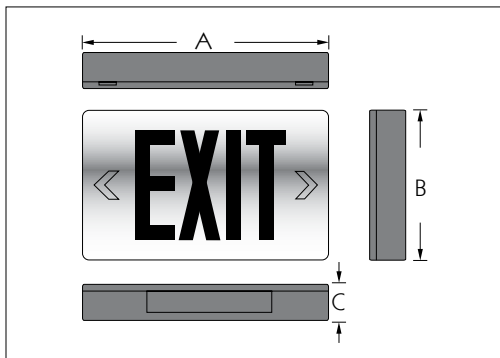

Wattage	A"	B"	C"
2x8W	17"	6 1/2"	4"

WARRANTY

The LC1 Series comes with a 5-year factory warranty. Deliberate damage, misuse, improper installation effectively cancels the warranty.



PRODUCT OVERVIEW

The LC1E series is designed to provide a durable, attractive and maintenance-free exit sign. The LC1E is manufactured from sturdy die-cast aluminum and comes standard with a brushed aluminum convex face and black housing. A universal mounting canopy is also included for ceiling and end mount applications. The LC1E series comes standard configured with high-output LED technology, available in red or green. AC only and Self-powered versions are available. The LC1E is damp location rated.

INTERNAL SPECIFICATIONS

AC ONLY: comes standard configured with high-output LED technology, 120/277VAC input.

SELF-POWERED: comes standard configured with high-output LED technology, 120/277VAC input. Nickel-Cadmium batteries provide a minimum 90 minutes of emergency duration. Solid state charger & transfer.

EXTERNAL SPECIFICATIONS

The LC1E series is constructed from durable die-cast aluminum and comes standard with a brushed aluminum face plate(s) and a black housing. Single, double and universal face versions must be specified. Available in custom epoxy-based powder coat finishes (please specify). Universal mounting knockouts are standard for ease of installation. Removable chevrons are standard on each face for field adjustability.

INSTALLATION

The LC1E series is suitable for ceiling, wall and end mounting. Suitable for damp location area installations.

ORDERING INFORMATION

Series	Model	LED	Face No.	Housing	Options
LC1E	HT (AC only)	LR (red)	1 (single)	W (white)	AT (auto-test)
	SA (self-powered)	LG (green)	2 (double)	B (black)	2CK (dual circuit)
			U (universal)	AL (aluminum)	

LC1E BUILDER

Series	Model	LED	Face No.	Housing	Options

EXAMPLE: LC1E-HT-LG1-B-AL
 DESCRIPTION: LC1E die cast exit, AC only, green LED, single face, black housing, brushed aluminum stencil.

JOB:	TYPE:
-------------	--------------

ELECTRICAL SPECIFICATIONS

The LC1E series is configured with high-output LED lamps. Standard with 120/277VAC input. All LED versions consume only 1.1W nominal power. Optional emergency illumination is provided by the LED light source at the following wattages

- 6VDC - 0.5 Watts
- 12VDC - 1.5 Watts
- 24VDC - 3.5 Watts

MECHANICAL SPECIFICATIONS

The LC1E series is constructed from durable die-cast aluminum. Universal mounting pattern and key hole slots are stamped on the back. A surface mount conduit entry knockout is also provided. Field removable directional chevron arrows are standard. The LC1E is supplied standard with a brushed aluminum face(s) and a black baked powder coat held securely in place with no visible screws, nuts or fasteners for a clean look.

DIE-CAST DESIGN

The excellent visual performance and architecturally pleasing design makes the LC1E series the premier choice for applications requiring the durability and the craftsmanship of die-cast aluminum exit signs. The standard brushed aluminum face blends well with any setting and provides a clean, contemporary look. The die-cast aluminum construction provides the LC1E series with exceptional rigidity and strength.

SELF-POWERED VERSION

The LC1E-SA series is designed to operate on battery power in the event of a regular/mains power failure. Both the battery and charger are completely contained within the standard enclosure. There are no external components and no alterations made to the external dimensions of the standard sign

BATTERY TECHNOLOGY

The LC1E-SA is designed with a maintenance free, Nickel-Cadmium battery providing a minimum emergent duration of 90 minutes. Recharge time is twenty-four (24) hours.

DIMENSIONS (in.)

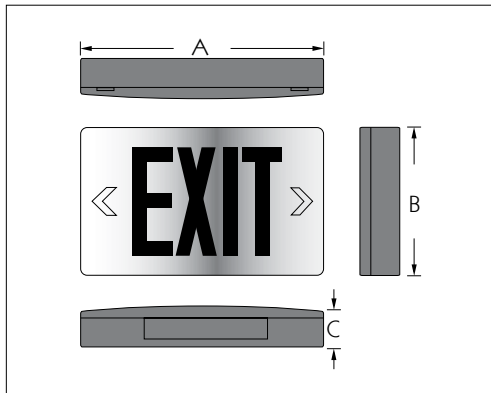

Series	A"	B"	C"
LC1-E	12.75"	8.5"	2"

WARRANTY

The LC1E Series comes with a 5-year factory warranty. Deliberate damage, misuse, improper installation effectively cancel the warranty.



PRODUCT OVERVIEW

The OL2 series has been developed with style, ease of installation and dependability in mind. Utilizing high-output indirect LED technology, the OL2 provides a recessed or surface mounted edge-lit EXIT sign with excellent light distribution. The OL2 series can be wall / ceiling recessed or surface mounted. End mount configurations are also available. The OL2 series can be configured for AC only and Self-Powered operation versions. The OL2 series features universal field adjustable chevrons.

INTERNAL SPECIFICATIONS

AC ONLY: comes standard configured with high-output LED technology, 120/277VAC input.

SELF-POWERED: comes standard configured with high-output LED technology, 120/277VAC input. Nickel-cadmium batteries provide a minimum 90 minutes of emergency duration. Optional 120 minute duration battery is available. Solid state charger & transfer.

EXTERNAL SPECIFICATIONS

The OL2 series housing backbox is constructed from durable 20 gauge steel. The acrylic face plate is available in both single face or double face versions, with a clear, white, mirrored or self-luminous background (please specify). Field adjustable chevrons are standard. Recessed versions are supplied standard with a white, baked powder coat steel trim plate. Available in custom epoxy-based powder coat finishes (please specify). External LED monitor light and test switch are standard on self-powered versions.

INSTALLATION

The OL2 series is suitable for recessed/surface ceiling or wall mounting. Suitable for indoor installations.

ORDERING INFORMATION

Series	Model	LED	Face No.	Panel Color	Mounting	Options
OL2	HT (AC only)	LR (red)	1 (single)	C (clear)	CR (ceiling recess)	AT (auto-test)
	SA (self-powered)	LG (green)	2 (double)	W (white)	WR (wall recess)	BA (brushed aluminum trim plate)
				M (mirror)	CS (ceiling surface)	PA (polished aluminum trim plate)
					WS (wall surface)	PB (polished aluminum brass plate)
					ES (end surface)	BR (bronze trim plate)
						SW (special wording-specify)
						SL (self-luminous face)
						IF (inverted face)
						PK (pendant kit - specify length)
						120SA (120 minute emergency)
						FAI (fire alarm interface)

012 BUILDER

Series	Model	LED	Face No.	Panel Color	Mounting	Options

EXAMPLE: OL2-SA-LR1-CCR
 DESCRIPTION: OL2 edge-lit exit, self-powered, red LED, single face, clear panel, ceiling recess.

JOB:	TYPE:
-------------	--------------

EDGE-LIT DESIGN

The **OL2** series of elegantly designed edge-lit exit signs feature a clean and contemporary look. The design brings style and flexibility to your next prestigious exit sign application. The indirect LED illumination evenly lights the acrylic face with crisp, even light. The ultra thin face plate virtually disappears once installed, yet the EXIT lettering boldly distinguishes the path of egress. The wide variety of finishes and mounting configurations available will ensure that the **OL2** series can be easily matched to your decor.

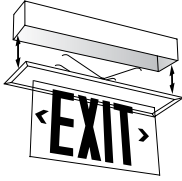

Trim and faceplate mount into backbox for quick and easy installation.

ELECTRICAL SPECIFICATIONS

The **OL2** series is configured with high-output LED lamps. Standard with 120/277VAC input. All LED versions consume only 1.1W nominal power. Optional emergency illumination is provided by the LED light source at the following wattages:

- 6VDC - 0.5 Watts
- 12VDC - 1.5 Watts
- 24VDC - 3.5 Watts

SELF LUMINOUS FACE

The **OL2** series can be ordered with an optional self-luminous face panel. The use of photoluminescent technology adds a new level of safety to current signage. The **OL2** series optional self-luminous panel automatically charges itself in one (1) hour using any available light source. The 80% phosphorus pigments create a white “glow” which allows the **OL2** edge-lit series to continually illuminate for up to 4 hours. The added element of safety that photoluminescent technology offers is ideal for use on every edge-lit installation.

SELF POWERED VERSIONS

The **OL2-SA** series is designed to operate on battery power in the event of a regular / mains power failure. Both the battery and charger are completely contained within the standard enclosure. There are no external components and no alterations made to the external dimensions of the standard sign. The **OL2-SA** self-powered series utilize a solid state transformer technology that eliminates the possibility of relay failure due to particle build up on the relay. Status is easily determined via an LED that indicates AC-ON. A push button test switch allows maintenance personnel to quickly confirm the operational status of the exit on AC fail.

BATTERY TECHNOLOGY

The **OL2-SA** is designed with a maintenance free, Nickel-Cadmium battery providing a minimum emergency duration of 90 minutes. An operational 120 minute Ni-Cad battery is available. Recharge time of the battery is twenty-four (24) hours. The maximum battery working temperature is 50° C.

MECHANICAL SPECIFICATIONS

The **OL2** series housing is constructed of sturdy 20 gauge steel. Universal mounting pattern and key hole slots are stamped into the housing providing various mounting options. Ceiling recessed versions are supplied standard with removable steel T-Bar ceiling tile mounting brackets. All trim plates are supplied standard with an attractive and durable white, baked powder coat finish. Other colors are available, including custom color matching, please specify. Face plates for the **OL2** series are constructed of clear, solid acrylic. Field removable directional chevron arrows are standard. Recessed version face plates are held securely in place with two (2) torsion spring clips that allows the face plate to accommodate uneven or angled ceilings and walls. This design leaves no visible screws, nuts or fasteners in the trim plate that would detract from the clean, modern design

WARRANTY

The **OL2** Series comes with a 5-year factory warranty. Deliberate damage, misuse, improper installation effectively cancel the warranty.

DIMENSIONS (in.)

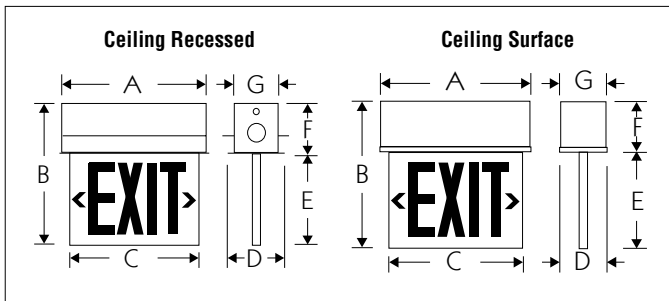

Series	A"	B"	C"	D"	E"	F"	G"
Ceiling Recessed	15"	12"	12"	5"	7"	4"	4"
Ceiling Surface	15"	12"	12"	4.25"	7"	4"	4"

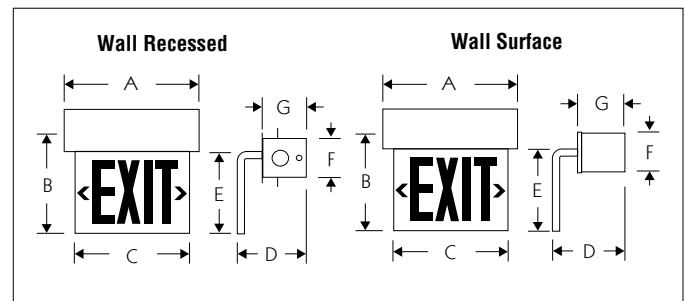

Series	A"	B"	C"	D"	E"	F"	G"
Wall Recessed	15"	10.5"	12"	4.5"	8"	5"	4"
Wall Surface	15"	10.5"	12"	4.5"	8"	4.25"	4"



PRODUCT OVERVIEW

The **OL2-TL** features a reduced size back box and trimplate; allowing for more flexibility during installation. High-output, high-efficiency LED's provide excellent and even light distribution across the edge-lit panel. The **OL2-TL** can be configured for surface or recess installations. The **OL2-TL** can be specified as AC only or self-powered. The **OL2-TL** features field adjustable chevrons

INTERNAL SPECIFICATIONS

AC ONLY: comes standard configured with high-output LED technology. 120/277VAC input.

SELF-POWERED: comes standard configured with high-output LED technology, 120/277VAC input. Nickel-Cadmium batteries provide a minimum 90 minutes of emergency duration. Optional 120 minutes duration battery is available. Solid state charger & transfer.

EXTERNAL SPECIFICATIONS

The **OL2-TL** series housing back-box is constructed from durable 20 gauge steel. The acrylic face plate is available in both single or double face configurations, with a clear, white, mirrored or self-luminous background (please specify). Field adjustable chevrons are standard. Custom wording is also available (please consult factory). Recess versions are supplied standard with a white, baked powder coat aluminum trim plate. Available in customer epoxy-based powder coat finishes (please specify). External LED monitor light and test switch are standard on self-powered versions.

INSTALLATION

The **OL2-TL** series is suitable for recessed/surface ceiling or wall mounting. Suitable for indoor installations

ORDERING INFORMATION

Series	Model	LED	Face No.	Panel Color	Mounting	Options
OL2-TL	HT (AC only)	LR (red)	1 (single)	C (clear)	CR (ceiling recess)	AT (auto-test)
	SA (self-powered)	LG (green)	2 (double)	W (white)	WR (wall recess)	BA (brushed aluminum trim plate)
M (mirror)					CS (ceiling surface)	PA (polished aluminum trim plate)
WS (wall surface)				PB (polished aluminum brass plate)		
ES (end surface)				BR (bronze trim plate)		
				SW (special wording-specify)		
	SL (self-luminous face)					
	IF (inverted face)					
	PK (pendant kit - specify length)					
	120SA (120 minute emergency)					

O12 BUILDER

Series	Model	LED	Face No.	Panel Color	Mounting	Options

EXAMPLE: OL2-TL-SA-LR1-CCR
 DESCRIPTION: OL2-TL edge-lit exit, self-powered, red LED, single face, clear panel, ceiling recess.

JOB:	TYPE:
-------------	--------------

EDGE-LIT DESIGN

The **OL2-TL** series of elegantly designed edge-lit exit signs feature a clean and contemporary look. The design brings style and flexibility to your next prestigious exit sign application. The indirect LED illumination evenly lights the acrylic face with crisp, even light. The ultra thin, clear face plate virtually disappears once installed, yet the EXIT lettering boldly distinguishes the path of egress. The wide variety of finishes and mounting configurations available will ensure that the **OL2-TL** series can be easily matched to your decor. Custom wording is also available.

ELECTRICAL SPECIFICATIONS

The **OL2-TL** series housing is constructed of sturdy 20 gauge steel. Universal mounting pattern and key hole slots are stamped into the housing providing various mounting options. Ceiling recessed versions are supplied standard with adjustable steel T-Bar ceiling tile mounting brackets. All trim plates are supplied standard with attractive and durable white, baked powder coat finish. Other colors are available, including custom color matching, please specify. Face plates for the **OL2-TL** series are constructed of clear, solid acrylic. Field removable directional chevrons are standard. Recessed version face plates are held securely in place with two (2) torsion spring clips that allow the face plate to accommodate uneven or angled ceilings and walls. This design leaves no visible screws, nuts or fasteners in the trim plate that would detract from the clean, modern design

BATTERY TECHNOLOGY

The **OL2-TL-SA** is designed with a maintenance free, Nickel-Cadmium battery providing a minimum emergency duration of 90 minutes. An operational 120 minute Nickel-Cadmium battery is available. Recharge time of the battery is twenty-four (24) hours. The minimum charging temperature is 0°C and the maximum charging temperature is 50°C.

SELF POWERED VERSIONS

The **OL2-TL-SA** series is designed to operate on battery power in the event of a regular/mains power failure. Both the battery and charger are completely contained within the standard enclosure. There are no external components and no alterations made to the external dimensions of the standard sign. The **OL2-TL-SA** self-powered series utilize a solid state transformer technology that eliminates the possibility of relay failure due to particle build up on the relay. Status is easily determined via an LED that indicates AC-ON. A push button test switch allows maintenance personnel to quickly confirm the operational status of the EXIT on AC fail.

SELF LUMINOUS FACE

The **OL2-TL** series can be ordered with an optional self-luminous face panel. The use of photoluminescent technology adds a new level of safety to current signage. The **OL2-TL** series optional self-luminous panel automatically charges itself in one (1) hour using any available light source. The 80% phosphorus pigments create a white “glow” which allows the **OL2-TL** edge-lit series to continually illuminate for up to 4 hours. The added element of safety that photoluminescent technology offers is ideal for use on every edge-lit installation.

WARRANTY

The **OL2-TL** Series comes with a 5-year factory warranty. Deliberate damage, misuse, improper installation effectively cancel the warranty.

DIMENSIONS (in.)

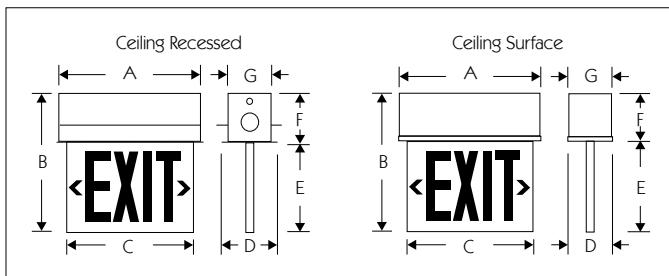

Series	A"	B"	C"	D"	E"	F"	G"
Ceiling Recessed	16.65"	12"	12"	2.75"	8"	4"	2"
Ceiling Surface	16.65"	12"	12"	2.4"	8"	4"	2"

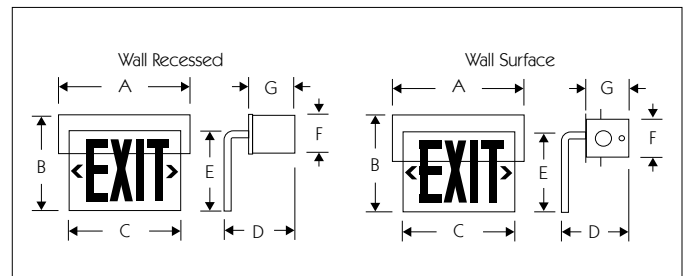

Series	A"	B"	C"	D"	E"	F"	G"
Wall Recessed	17.5"	10"	12"	5.5"	8"	2"	4"
Wall Surface	17"	10"	12"	5.5"	8"	2"	4"



PRODUCT OVERVIEW

The **CYCLONE** edge-lit Exit features a clean, cylindrical design. When paired with die-cast canopy, the **CYCLONE** provides a fresh approach to the traditional exit sign. The “quick slide” canopy allows in-field adjustment from wall mount to ceiling mount. Utilizing direct, high-output, high efficiency LED’s, the **CYCLONE** illuminates with a crisp and even light distribution. The **CYCLONE** can be wall, ceiling or end mounted. Wall and ceiling are field adjustable, end mount configuration must be specified. The **CYCLONE** is available in AC only and Self-powered variations. Field adjustable chevrons are standard.

ORDERING INFORMATION

Series	Model	LED	Face No.	Panel Color	Mounting	Options
CYC	HT (AC only)	LR (red)	1 (single)	C (clear)	WCS (wall/ceiling surface)	B (black housing)
	SA (self-powered)	LG (green)	2 (double)	W (white) M (mirror)	ES (end surface)	BA (brushed aluminum) PA (polished aluminum) AN (anodized finish - specify) BR (bronze) SW (special wording-specify) SL (self-luminous face) CC (custom color) PK (pendant kit - specify length)

CYCLONE BUILDER

Series	Model	LED	Face No.	Panel Color	Mounting	Options

EXAMPLE: CYC-SA-LR2-W-WCS-B
 TION: Cyclone edge-lit exit, self-powered, red LED, double face, white panel, ceiling surface, black housing.

DESCRIP-

JOB:	TYPE:
-------------	--------------

INTERNAL SPECIFICATIONS

AC ONLY: comes standard configured with high-output LED technology, 120/277VAC input.

SELF-POWERED: comes standard configured with high-output LED technology, 120/277VAC input. Nickel-cadmium batteries provide a minimum 90 minutes of emergency duration. Solid state charger & transfer.

EXTERNAL SPECIFICATIONS

The **CYCLONE** series cylindrical housing is constructed as a single piece from extruded aluminum. The canopy is made from durable die-cast aluminum and the end caps from machined aluminum. The high clarity acrylic face plate is available in both single face or double face versions, with a clear, white, mirrored or self-luminous background (please specify). Field adjustable chevrons are standard. White, baked powder coat finish is standard on all versions. Available in custom colors and finishes (please specify). External LED monitor light and test switch are standard on self-powered versions.

INSTALLATION

The **CYCLONE** is suitable for surface ceiling, wall and end mounting. Suitable for indoor installations.

MODERN DESIGN

The **CYCLONE** series of cylindrical designed edge-lit exit signs feature a radical, high-tech look. The design lends cutting edge technology and style to today's modern interior exit sign applications. The one-piece cylindrical body is extremely rigid and holds all of the LED circuitry in precision formed mounting channels. The indirect LED illumination provided by this design evenly lights the acrylic face with crisp, even light. The clear area of the ultra thin face plate virtually disappears once installed. The choice of clear, white, mirrored or self-luminous backgrounds allow the **CYCLONE** series to be best matched to the decor. A wide variety of finishes and mounting configurations available will ensure that the **CYCLONE** can be suited to your installation.

ELECTRICAL SPECIFICATIONS

The **CYCLONE** series is configured with high-output LED lamps. Standard with 120/277VAC input. All LED versions consume only 1.1W nominal power. Optional emergency illumination is provided by the LED light source at the following wattages:

6VDC	- 0.5 Watts
12VDC	- 1.5 Watts
24VDC	- 3.5 Watts

BATTERY TECHNOLOGY

The **CYCLONE-SA** is designed with a maintenance free, Nickel-Cadmium battery providing a minimum emergency duration of 90 minutes. Recharge time of the battery is twenty-four (24) hours. The maximum battery working temperature is 50° C.

SELF-POWERED VERSIONS

The **CYCLONE-SA** self-powered series is designed to operate on battery power in the event of a regular / mains power failure. Both the battery and charger are completely contained within the standard enclosure. There are no external components and no alterations made to the external dimensions of the standard sign. The **CYCLONE-SA** self-powered series utilize a solid state transformer technology that eliminates the possibility of relay failure due to particle build up on the relay. Status is easily determined via an LED that indicates AC-ON. A push button test switch allows maintenance personnel to quickly confirm the operational status of the exit on AC fail

SELF-LUMINOUS FACE

The **CYCLONE** series can be ordered with an optional self-luminous face panel. The use of photoluminescent technology adds a new level of safety to current signage. The **CYCLONE** series optional self-luminous panel automatically charges itself in one (1) hour using any available light source. The 80% phosphorus pigments create a white "glow" which allows the **CYCLONE** edge-lit series to continually illuminate for up to 4 hours. The added element of safety that photoluminescent technology offers is ideal for use on every edge-lit installation.

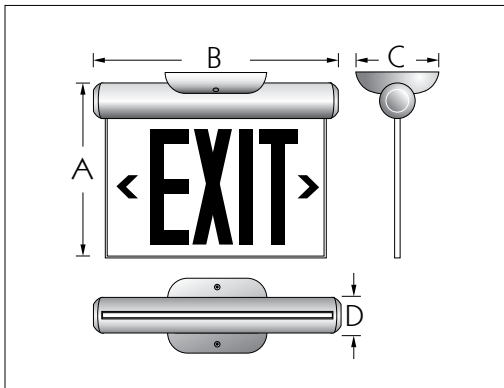
DIMENSIONS (in.)

Series	A"	B"	C"	D"
CYC	9"	12.5"	"	2"

WARRANTY

The **CYCLONE** Series comes with a 5-year factory warranty. Deliberate damage, misuse, improper installation effectively cancel the warranty.



INTERNAL SPECIFICATIONS

AC ONLY: comes standard configured with high-output LED technology, 120/277VAC input.

EXTERNAL SPECIFICATIONS

The **MICRA** series extruded “fusion” body is constructed as a single piece from extruded aluminum. The canopy is made from 16 gauge steel; the exit body end plates are constructed from machined aluminum. White, baked powder coat finish is standard on all versions. **MICRA** is also available in an all brushed aluminum finish. Single or double face versions must be specified. Universal mounting pattern and key hole slots are stamped into the back plate. Chevron arrows can be specified, otherwise universal chevron arrows are supplied.

INSTALLATION

The **MICRA** is suitable for ceiling, wall and end mounting. Suitable for indoor installations.

PRODUCT OVERVIEW

The **MICRA** series of exit signs feature an ultra thin extruded aluminum design. The one piece body is extruded to exacting standards producing an extremely rigid body that eliminates any light leaks. The ultra narrow profile provides a stylish and contemporary appearance, perfectly suited to modern business and commercial decors. The **MICRA** can be wall, ceiling or end mounted and configured with high-output LED’s for AC only and self-powered variations.

ORDERING INFORMATION

Series	Model	LED	Face No.	Mounting	Chevron (S version only)	Chevron Type	Options
MCA	HT (AC only)	LR (red)	1 (single)	W (wall - no canopy)	0 (no chevron)	S (specified)	BA (brushed aluminum trim plate)
	SA (self-powered)	LG (green)	2 (double)	C (ceiling - w/canopy)	L (left)	F (flush)	AN (anodized finish - specify)
				E (end - w/canopy)	R (right)	R (recessed)	SW (special wording-specify)
					D (double arrow)		CC (custom color)
							PK12 (12" pendant kit)

MICRA BUILDER

Series	Model	LED	Face No.	Mounting	Chevron (S version only)	Chevron Type	Options

EXAMPLE: MCA-HT-LG2-C-S-L

DESCRIPTION: Micra extruded aluminum exit, AC only, green LED, double face, ceiling mount, specified chevrons, left.

JOB:	TYPE:
-------------	--------------

ADVANCED DESIGN

The **MICRA** series of extruded aluminum signs feature an ultra thin “fusion” one-piece body. The design incorporates cutting edge technology, producing one of the slimmest aluminum exits ever manufactured. The one-piece body is extremely rigid and holds all of the LED circuitry in precision formed mounting channels. The LED illumination provided by this design evenly illuminates the exit face; while the ultra thin design “traps” light, further enhancing output. The canopy has been custom designed to complement the ultra thin appearance of the **MICRA**, as well as provide a stable and rigid mounting platform. A wide variety of finishes are available, ensuring that the **MICRA** can be suited to your installation

MECHANICAL SPECIFICATIONS

The **MICRA** “fusion” body is constructed from a single piece of extruded aluminum. All mounting channels are extruded with the housing at the time of manufacture, adding to the rigidity of the sign. The housing end plates are machined from solid aluminum and secured to the housing with two (2) screws. The **MICRA** canopy is made from 16 gauge steel and is attached to the housing at the factory to provide the most secure mounting possible. The **MICRA** is supplied standard with a durable white, baked powder coat finish. Other colors are available, including custom color matching, please specify. All exit face wording, mounting patterns and chevron arrows are cut during the manufacturing process. Single or double face versions must be specified. Custom wording / graphics are available, please specify.

DIMENSIONS (in.)

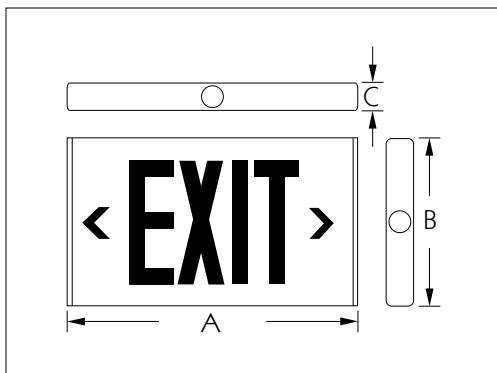

Series	A"	B"	C"
MCA	12"	9"	1.25"

CHEVRON ARROWS

The **MICRA** series chevron arrows can be specified at the time of order to exactly match specifications. Otherwise, universal chevrons are cut and field selectable chevron blanks may be arranged to suit installation specifications. The chevron options available for the **MICRA** series are:

S - Specified Chevrons

Chevrons are specified at the time of order (none, left, right or double) and only those chevrons are cut into the exit sign during manufacturing. Chevrons are not field adjustable.

F - Flush Chevrons

Both chevrons are cut into the exit. Color matched chevron blanks are fitted into the chevron holes. The blanks are designed to fit flush to the finished exit face, minimizing the appearance of the blanked out chevron. Chevrons are field adjustable by removing the blank(s).

R - Recessed Chevrons

Both chevrons are cut into the exit. Color matched chevron blanks are placed behind the chevron holes to cover the fiber. Chevrons are field adjustable by removing the blank(s).

ELECTRICAL SPECIFICATIONS

The **MICRA** series is configured with high-output LED lamps. Standard with 120/277VAC input. All LED versions consume only 2W nominal power.

SELF-POWERED VERSIONS

The **MICRA** self-powered series is designed to operate on battery power in the event of a regular / mains power failure. Both the battery and charger are completely contained within the standard enclosure. There are no external components and no alterations made to the external dimensions of the standard sign. The **MICRA** self-powered series utilize a solid state transformer technology that eliminates the possibility of relay failure due to particle build up on the relay. Status is easily determined via an LED that indicates AC-ON. A push button test switch allows maintenance personnel to quickly confirm the operational status of the exit on AC fail.

BATTERY TECHNOLOGY

The **MICRA** is designed with a maintenance free, sealed Nickel-Cadmium battery providing a minimum emergency duration of 90 minutes. An optional 120 minute Nickel-Cadmium battery is available. Recharge time of the battery is twenty-four (24) hours. The maximum battery working temperature is 50° C.

WARRANTY

The **MICRA** Series comes with a 5-year factory warranty. Deliberate damage, misuse, improper installation effectively cancel the warranty.

Industrial Application Exits

SECTION SIX



CONTENTS



Fortezza Series	
Die-Cast Aluminum, LED	Page
Ceiling, wall and end installed product specification. Wet Location / IP66	108
Technical Data	109



WLX Series	
Fiberglass, LED	Page
Ceiling, wall and end installed product specification. NEMA 4X	110
Technical Data	111



EVR Series	
14ga steel construction, LED	Page
Ceiling, wall and end installed product specification.	112
Technical Data	113



TSL Series	
Tritium	Page
Ceiling wall and end installed product specification.	114
Technical Data	115



DLX Series	
Photoluminescent	Page
Ceiling wall and end installed product specification.	116
Technical Data	117



PRODUCT OVERVIEW

The **FORTEZZA** series heavy duty exit sign is designed to stand up to high abuse areas such as correctional facilities, schools, apartment complexes, and public areas that may be subject to vandalism. The heavy gauge cast aluminum housing and high abuse polycarbonate faceplate offers extreme protection and superior performance with a contemporary look. Tamper resistant screws insure the integrity of the unit. Perforated chevrons allow for on-site selection. The **FORTEZZA** comes standard with a high reflective white powder coat inside the housing to maximize the LED distribution. The **FORTEZZA** is also available with high output LED's in AC only and self-powered operations

AC ONLY: standard 120/277/347 VAC input.

SELF-POWERED: standard self powered versions use sealed Nickel-Cadmium batteries to provide a minimum of 90 minutes of emergency duration. Optional 120 minutes duration battery is available. Solid state charger, auto-test, and transfer are standard on self powered units.

EXTERNAL SPECIFICATIONS

The **FORTEZZA** is wet location /IP 66 rated. The **FORTEZZA** utilizes a long-life neoprene gasket. An internal heater option with thermostat is available for low temperature installations. (See selection guide for ordering information and available options).

INTERNAL SPECIFICATIONS

The **FORTEZZA** series is constructed from .420" thick, heavy duty cast aluminum. The face plates are protected by high abuse clear polycarbonate, which is recessed into the housing. Tamper resistant screws are standard. The **FORTEZZA** series comes standard black, although color options are available upon request. Single, double or universal face plate configuration must be specified. The self powered version comes standard with an external LED status indicator and test switch.

INSTALLATION

The **FORTEZZA** series exit is supplied with a canopy and is suitable for surface ceiling, wall and end mount applications. Suitable for indoor, outdoor, damp or wet applications.

ORDERING INFORMATION

Series	Model	LED	Face No.	Mounting	Standard	Options
FTZ	HT (AC only)	LR (red)	1 (single)	W (wall - no canopy)	AT (auto-test)	WW (white/white)
	SA (self-powered)	LG (green)	2 (double)	C (ceiling - w/canopy)		BB (black/black)
			U (universal)	E (end - w/canopy)		PK (pendant kit - specify length)
				U (universal)		FL (flashing alarm)
						BZ (audible alarm)
						SW (special wording - specify)
						IH (internal - heater)
						IR (infrared remote test switch)
						120 SA (120 min emergency)

FORTEZZA BUILDER

Series	Model	LED	Face No.	Mounting	Standard	Options

EXAMPLE: FTZ-HT-LR1-W-BZ-AT-BZ
 DESCRIPTION: FORTEZZA exit AC only, red LED, single face, wall mount, audible alarm, autotest

JOB:	TYPE:
-------------	--------------

VANDAL RESISTANT DESIGN

The ultra heavy duty design and appearance of the FORTEZZA series exit warns potential vandals that this is no regular sign. The stencil is protected by a 1/8" thick, impact resistant polycarbonate shield that is recessed into the housing and fastened with 4 tamper resistant screws. The FORTEZZA offers a contemporary look and durability like no other.

MECHANICAL SPECIFICATIONS

The FORTEZZA series is constructed of extra heavy duty cast aluminum with a 1/8" thick polycarbonate protective shield. Tamper resistant screws are standard. Field adjustable chevrons are standard. The FORTEZZA is standard in an attractive matte black finish. Other colors are available, including custom color matching to meet the customer's needs. The polycarbonate face shield is recessed into the housing making the Fortezza series one of the most rigid, yet attractive high abuse signs on the market.

AUTOTEST DIAGNOSTIC

The self-powered FORTEZZA comes standard with Beghelli Autotest diagnostic system. Featuring continuous monitoring of the units main components (battery, charger, transformer, lamps & LED's) and providing instant visual verification of the status.

ELECTRICAL SPECIFICATIONS

The FORTEZZA series is configured with high output LED lamps. LED is standard with 120/277/347VDC input. All LED version consume < 5 watts nominal power

SELF-POWERED VERSIONS

The FORTEZZA-SA self powered series is designed to operate on battery power in the event of a regular/mains power failure. Both battery and charger are completely contained within the standard enclosure. The FORTEZZA-SA self-powered series utilize a solid state transformer technology that eliminates the possibility of relay failure due to particle build up on the relay. Status is easily determined via an LED that indicates AC-ON.

BATTERY TECHNOLOGY

The FORTEZZA-SA series is designed with a maintenance free, sealed Nickel-Cadmium battery providing a minimum emergency duration of 90 minutes. An optional 120 minutes Nickel-Cadmium battery is available. Recharge time of the battery is twenty-four (24) hours. The maximum battery operating temperature is +45°F and the minimum is +0°F without internal heater/thermostat option. The minimum operating temperature with internal heater/thermostat is -40°F/°C

DIMENSIONS (in.)

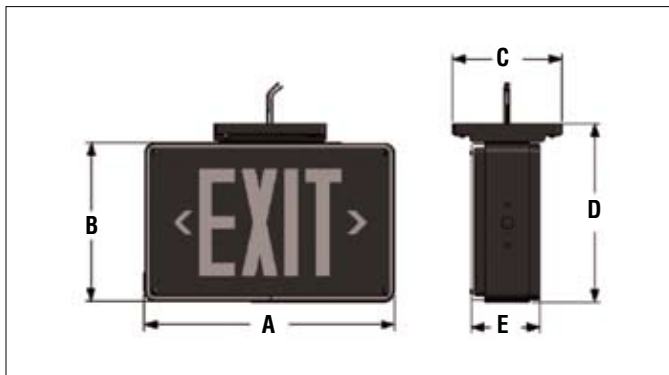

Series	A"	B"	C"	D"	E"
FTZ	14"	9"	6.2"	10"	4"

WARRANTY

The FORTEZZA Series comes with a 5-year factory warranty.. Deliberate damage, misuse, improper installation effectively cancel the warranty.



PRODUCT OVERVIEW

The **W^LX** series of exits are designed with the extremes of the environment in mind. The fully gasketed polycarbonate lens and fiberglass housing allows the **W^LX** series to be installed in locations that require NEMA 4X protection.

Optional weather-proof Par36 emergency lighting heads can also be installed on this unit. The **W^LX** series is available configured with high-output LED's in AC only and Self-Powered operation versions.

INTERNAL SPECIFICATIONS

AC ONLY: standard 120/277VAC input

SELF-POWERED: standard self-powered versions use sealed nickel-cadmium batteries to provide a minimum 90 minutes of emergency duration. Maintenance free sealed lead acid battery used when optional emergency heads are ordered. Optional 120 minute duration battery is available. Solid state charger and transfer.

EXTERNAL SPECIFICATIONS

The **W^LX** series housing is constructed from durable, corrosion resistant fiberglass. The housing is fully gasketed for wet location applications and is supplied standard in a gray finish. Four (4) polycarbonate pressure screws firmly hold the polycarbonate lens in place. Wall, ceiling or end mounting configurations are available. Single or double face versions must be specified. Removable chevron arrows are standard on each unit. The self-powered version comes standard with an external LED status indicator and test switch.

LAMP SELECTION

6V sealed beam: (SB) standard: 9w, 18w, 25w
 (SBH) halogen: 12w, 20w

ORDERING INFORMATION

Series	Model	LED	Face No.	Mounting	Heads (combination only)	Operation (combination only)	Options
W ^L X	HT (AC only)	LR (red)	1 (single)	W (wall - no canopy)	0 (none)	6-27 (6v 27w)	AT (auto-test)
	SA (self-powered)	LG (green)	2 (double)	C (ceiling - w/canopy)	1LR (one par36)	6-36 (6v 36w)	FP (food prep lens)
				E (end - w/canopy)	2LR (two par36)	6-54 (6v 54w)	PK (pendant kit - specify length)
							FL (flashing alarm)
							BZ (audible alarm)
							SW (special wording - specify)
							IH (internal - heater 120V or 277V)
							2CK (dual-circuit)
							120 SA (120 min emergency)
							FAI (fire alarm interface)

W^LX BUILDER

Series	Model	LED	Face No.	Mounting	Heads	Operation	Options

EXAMPLE: W^LX-SA-LR1-C-IH(120v)

DESCRIPTION: W^LX wet location exit, self-powered, red LED, single face, ceiling mount, internal heater 120V.

JOB:	TYPE:
-------------	--------------

ELECTRICAL SPECIFICATIONS

The **WLX** series is configured with high-output LED lamps. LED is standard with 120/277VAC input. All LED versions consume only 1.1W nominal power. Optional emergency illumination is provided by the LED light source at the following wattages:

- 6VDC - 0.5 Watts
- 12VDC - 1.5 Watts
- 24VDC - 3.5 Watts

CHARGER SPECIFICATIONS

The **WLX** series utilizes a solid state transfer technology that eliminates relay failure that can be caused by particle build up on the relay. All of the components used in the circuitry are temperature compensated. Status is easily determined via the LED display. A push button test switch allows maintenance personnel to quickly confirm the operational status of the exit on AC fail.

DOUBLE FACE DESIGN

Beghelli USA offers an innovative, compact designed double face version of the **WLX**.

MECHANICAL SPECIFICATIONS

The **WLX** series housing is constructed from durable, corrosion resistant fiberglass. The housing is fully gasketed for damp, wet and NEMA 4X locations with a hot-bonded silicone gasket. Exit face(s) are made from a high clarity, clear polycarbonate. Custom face colors and special wording / graphics are available, please specify. Field removable chevron arrows are standard on each face. Four (4) polycarbonate pressure screws firmly hold the face to the housing. Optional Par36 heads are constructed of high-impact, black thermoplastic that has been sealed against moisture infiltration.

DIMENSIONS (in.)

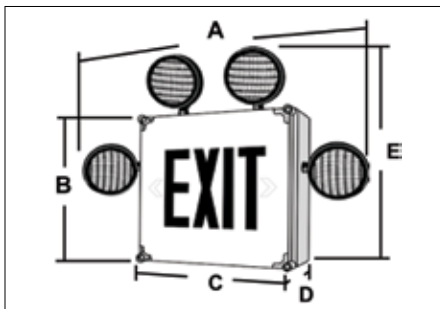

Series	A"	B"	C"	D"	E"
WLX	24"	12"	12"	5"	18"

EXTREME CLIMATE DESIGN

The **WLX** series has been designed to perform in applications where the climate would punish any standard sign. The entire internal cavity of the sign is protected from moisture invasion by an extremely resilient gasket. The gasketing is "hot-bonded" to the lens during the manufacturing process. This procedure eliminates any chance of the gasketing to become dry and pull away from the lens. The gasketing always holds its original form and has "memory retention" so that it effectively and consistently protects the **WLX** series from moisture. The **WLX** can also be equipped with an optional thermostatically controlled heater for cold environments. The fiberglass housing is highly corrosion resistant and will not rust or rot. The molded fiberglass finish cannot be scraped or scratched away exposing raw metals like standard steel signs.

BATTERY TECHNOLOGY

The **WLX-SA-6-27**, **6-36** and **6-54** are designed with an internal, maintenance free, valve regulated sealed lead-acid battery providing emergency lighting duration as per specified unit. The **WLX-SA** is designed with an internal maintenance free, sealed Nickel-Cadmium battery providing a minimum emergency duration of 90 minutes. An optional 120 minute Nickel-Cadmium battery is available. Recharge time of the battery is twenty-four (24) hours. The maximum battery operating temperature is 50° C.

MODEL RATING GUIDE

Model	Voltage	Wattage			
		90min	120min	180min	240min
WLX-SA-6-27	6	27	18	12	NA
WLX-SA-6-36	6	36	27	18	12
WLX-SA-6-54	6	54	36	27	18

NOTE: self-powered for up to 120 minutes w/ optional battery for external loads.

WARRANTY

The **WLX** Series comes with a 5-year factory warranty. Lamps are not covered under the warranty. Deliberate damage, misuse, improper installation effectively cancel the warranty.



PRODUCT OVERVIEW

The **EVR** series of vandal resistant exits are designed to stand up to abuse in applications such as schools, public areas, institutions and apartment complexes where vandalism may potentially occur. The 14 gauge steel and polycarbonate faceplate offers extreme protection and superior performance. Tamper resistant screws insure the integrity of the unit. The heavy gauge steel construction of the **EVR** housing requires that directional chevron arrows must be specified when ordering. The **EVR** series is available configured with high-output LED's in AC only and self-powered operation versions.

INTERNAL SPECIFICATIONS

AC ONLY: standard 120/277VAC input

SELF-POWERED: standard self-powered versions use sealed nickel-cadmium batteries to provide a minimum 90 minutes of emergency duration. Optional 120 minute duration battery is available. Solid state charger and transfer.

EXTERNAL SPECIFICATIONS

The **EVR** series is constructed from heavy duty steel. Exit face(s) are 14 gauge steel backed with impact resistant polycarbonate. Tamper resistant screws are standard. The **EVR** series comes standard with a white baked powder coat finish. Available in custom epoxy-based powder coat finishes (please specify). Single, double or universal face versions must be specified. The self-powered version comes standard with an external LED status indicator and test switch.

INSTALLATION

The **EVR** series exit is suitable for surface ceiling, wall and end mounting. Suitable for indoor installations.

ORDERING INFORMATION

Series	Model	LED	Face No.	Mounting	Options
EVR	HT (AC only)	LR (red)	1 (single)	W (wall - no canopy)	AT (auto-test)
	SA (self-powered)	LG (green)	2 (double)	C (ceiling - factory installed) E (end - factory installed)	FL (visual alarm - specify voltage) CC (custom color - specify) BZ (audible alarm) SW (special wording - specify) PK12 (12" pendant kit) 2CK (dual-circuit) 120 SA (120 min emergency) FAI (fire alarm interface)

EVR BUILDER

Series	Model	LED	Face No.	Mounting	Options

EXAMPLE: EVR-HT-LR1-W-AT
DESCRIPTION: EVR vandal exit, AC only, red LED, single face, wall mount, auto-test.

JOB:	TYPE:
-------------	--------------

VANDAL RESISTANT DESIGN

The ultra heavy duty design and appearance of the **EVR** series exit warns potential vandals that this is no regular sign. The face plate is constructed of durable 14 gauge steel that wraps around the frame for added protection. The exit is further protected by 1/8" thick, impact resistant polycarbonate that is sandwiched between the steel face plate and the stencil fiber. The form fitting face plate is attached to the frame with four (4) tamper resistant stainless steel screws. The all steel exit frame has been folded along the face and back plate edges in order to provide superior strength and durability. The steel back plate is also attached with four (4) stainless steel screws. Unlike incandescent light sources, the LED technology used in the **EVR** series does not contain any delicate filaments or films that can lead to failure due to impact related damage. For ceiling and end mount applications the **EVR** series is supplied with an extra heavy duty canopy (factory installed) that provides superior mounting strength.

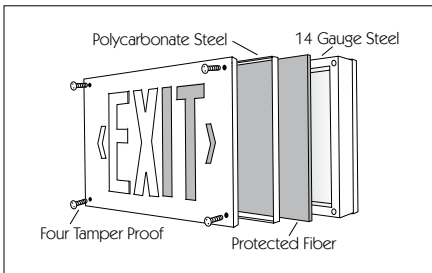

ELECTRICAL SPECIFICATIONS

The **EVR** series is configured with high-output LED lamps. LED is standard with 120/277VAC input. All LED versions consume only 1.1W nominal power. Optional emergency illumination is provided by the LED light source at the following wattages:

- 6VDC - 0.5 Watts
- 12VDC - 1.5 Watts
- 24VDC - 3.5 Watts

DIMENSIONS (in.)

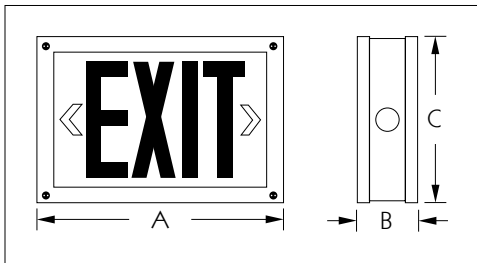

Series	A"	B"	C"
EVR	12.25"	3"	8.5"

MECHANICAL SPECIFICATIONS

The **EVR** series is constructed of extra heavy duty steel with a 14 gauge steel face plate. Tamper resistant screws are standard. Exit fiber(s) are covered with impact resistant polycarbonate. Due to the extreme gauge of steel, directional chevron arrows must be specified when ordering. The **EVR** series is supplied standard with an attractive and durable white, baked powder coat finish. Other colors are available, including custom color matching, please specify. The advanced design of the **EVR** leaves it with no extraneous holes or slots that could be utilized by vandals for gaining entry. The face plate securely holds the shield and fiber in place by wrapping around the exit frame, increasing the rigidity of the entire unit.

SELF-POWERED VERSIONS

The **EVR-SA** self-powered series is designed to operate on battery power in the event of a regular / mains power failure. Both the battery and charger are completely contained within the standard enclosure. There are no external components and no alterations made to the external dimensions of the standard sign. The **EVR-SA** self-powered series utilize a solid state transformer technology that eliminates the possibility of relay failure due to particle build up on the relay. Status is easily determined via an LED that indicates AC-ON. A push button test switch allows maintenance personnel to quickly confirm the operational status of the exit on AC fail.

BATTERY TECHNOLOGY

The **EVR-SA** series is designed with a maintenance free, sealed Nickel-Cadmium battery providing a minimum emergency duration of 90 minutes. An optional 120 minute Nickel-Cadmium battery is available. Recharge time of the battery is twenty-four (24) hours. The maximum battery operating temperature is 50° C.

WARRANTY

The **EVR** Series comes with a 5-year factory warranty. Deliberate damage, misuse, improper installation effectively cancel the warranty.



PRODUCT OVERVIEW

The TSL series of self-luminous exits are designed for easy installation. The use of internally sealed tritium gas as the illumination source reduces general maintenance issues and operational costs. The TSL series does not require electrical power, wiring or batteries. The TSL series is available in single or double face versions. Housings are available constructed from durable corrosion resistant thermoplastic or industrial grade aluminum, please specify when ordering. The TSL series is offered in 10 or 20 year versions.

INTERNAL SPECIFICATIONS

The TSL series housing is available constructed from durable, corrosion resistant ABS thermoplastic or optional industrial grade aluminum. The TSL housing is supplied standard with a red on white stencil and white or black frame finish. Wall, ceiling or end mounting configurations are available. Single or double face versions must be specified. Removable field adjustable chevron arrows are standard on each unit.

EXTERNAL SPECIFICATIONS

The TSL series exit is suitable for surface ceiling, wall and end mounting. Suitable for wet, cold and hazardous location installations.

INSTALLATION

The TSL series exit is suitable for surface ceiling, wall and end mounting. Suitable for wet, cold and hazardous location installations.

ORDERING INFORMATION

Series	Model	Duration	Face No.	Stencil	Frame	Mounting	Options
TSL	PT (Plastic frame)	10 (ten years)	1 (single)	R (red)	W (white)	W (wall)	CC (custom color - specify)
	AT (aluminum frame)	20 (twenty years)	2 (double)	G (green)	B (black)	C (ceiling)	SW (special wording - specify)
	IN (institutional frame)					E (end)	PK (pendant kit)

TSL BUILDER

Series	Model	Duration	Face No.	Stencil	Frame	Mounting	Options

EXAMPLE: TSL-IN-10-1-RB-W
 DESCRIPTION: TSL self-luminous exit, institutional frame, 10 years, single, red stencil, black frame, wall mount.

JOB:	TYPE:
-------------	--------------

PRACTICAL DESIGN

The TSL series has been designed to perform in just about any environment. Requiring no external power source, installation is effortless and efficient. The practical design of the TSL series allows installation and maintenance to be at a minimum. Since an external power source is not required, the installation of the TSL series is not restricted by location or the lack of an easily accessible power source

EFFICIENT PERFORMANCE

The TSL series is a completely self-powered, illuminated exit sign requiring no external power source of any kind. Barring destruction of the unit, the TSL series self-luminous sign must be accounted for as being totally reliable during its predicted life. The TSL series exit sign is always "ON" requiring no wiring or electrical installation, and as a practical and environmental matter, consumes no power of any kind. The TSL series average life expectancy is 10 - 20 years.

LIGHT SPECIFICATIONS

The TSL series uses self-luminous tritium as a light source. Although this source emits light, it cannot be considered or measured in the same sense as incandescent (point) sources, where light is emitted evenly from an area rather than a point surface. The conventional unit of measurement is the microlambert. For convenience, the following definitions are provided:

MECHANICAL SPECIFICATIONS

The TSL series is manufactured under stringent quality control procedures and meet all requirements of the Atomic Energy Control Board (AECB) and the Federal Nuclear Regulatory Commission. Illumination is achieved by using a permanent internal light source. Tritium emits relatively low energy beta particles that bombard the phosphorus coated glass tubes, this action generates light. Light emitting phosphors are designed and selected according to their color and light production efficiency. The TSL series features several glass envelopes (tubes) that are encased behind plastic housing light diffusers. To reduce chances of breakage, the TSL series features tritium tube shockproof mountings made of PVC.

PRODUCT REGISTRATION

The TSL series requires that the manufacturer register the actual installation location of every self-luminous tritium exit sold. When ordering the TSL series, Beghelli USA will require that included on the purchase order is the end users address, phone number and contact name. Beghelli USA will then register the installation with the Federal Nuclear Regulatory Commission as per required by law.

Lambert = The unit of brightness equal to 1/candles/cm
 Foot Lambert = The unit of brightness equal to 1/candles/ft = approximately 1000 microlamberts
 (the conversion factor is microlamberts = 1076 x foot lamberts, and foot lamberts = microlamberts /1076).

DIMENSIONS (in.)

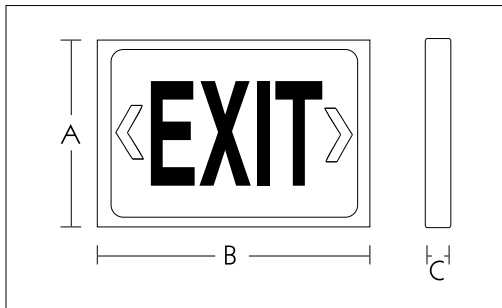

Series	A"	B"	C"
TSL	8"	12"	1.8"

WARRANTY

The TSL Series comes with a 10 to 20 year factory warranty. Deliberate damage, misuse, improper installation effectively cancel the warranty.



PRODUCT OVERVIEW

Unparalleled in reliability, the DLX series utilizes photoluminescent technology which absorbs and stores ambient light. In the event of a power failure, or a smoky environment, the DLX is a clearly recognizable egress sign. Since there is no electricity required, the DLX is a safer signage solution, which saves on maintenance and energy costs. The DLX is NON-TOXIC and NON-RADIOACTIVE which eliminates disposal fees.

EXTERNAL SPECIFICATIONS

The DLX series is constructed of durable .035 steel with integrated, high grade photo luminescent panel, or photoluminescent panel only with silk screened font. The steel housing is available in black (standard), white, green, and safety red. Silk screened lettering is available in both red and green.

INSTALLATION

Surface ceiling, wall or end mount applications

FEATURES

- Consumes no electricity
- 100% reliable, no internal parts to brownout
- Non-toxic, non-radioactive
- Low-cost, easy installation
- Configured for universal mounting
- Low profile
- Can be used for high and/or low level installations
- Field adjustable chevrons
- 25+ years life expectancy
- UL924 listed, meets NFPA Life Safety Code 101 & OSHA requirements
- Meets current building codes: IBC, ICBO, BOCA, & SBCCI, NFPA5000
- Ideal for wet or hazardous locations
- Visible at 50' during a blackout condition

ORDERING INFORMATION

Series	Face	Housing	Housing Color ("st" only)	Mounting
DLX	P1 (single face)	X (panel only)	W (white)	W (wall)
	P2 (double face)	ST (steel housing)	B (black)	C (ceiling - ST only)
			R (red)	E (end - ST only)

DLX BUILDER

Series	Face	Housing	Housing Color ("st" only)	Mounting

EXAMPLE: DLX-P1-ST-B-W
 DESCRIPTION: DLX series photo luminescent exit sign, single face, steel housing (black), wall mount

JOB:	TYPE:
-------------	--------------

DIMENSIONS (in.)

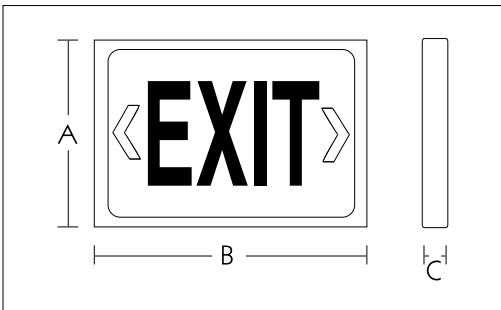

Series	A"	B"	C"
DLX	15.25"	8.25"	.25"

Remotes

Remotes, Power Packs & Inverters

SECTION SEVEN

EMERGENCY



CONTENTS



Remote Series

	Page
Single, Double and Triple head remotes	122



Luce Series

	Page
500-3000 lumen emergency ballasts	
Technical Data	126



Forza Inverter Series

	Page
Single and three phase	
Technical Data	127



SRP - PAR18 Small Style Emergency Remote

The **SRP** series of remotes are constructed of high impact thermoplastic and feature an innovative rotary locking collar design that securely locks the lens and reflector assembly into place. The locking collar allows maintenance personnel to quickly and easily complete relamping. A mechanically adjustable swivel locks the head in position once adjusted. The matching canopy fits nearly all standard electrical junction boxes. The **SRP** series is supplied standard in a white color, black color is optional.

LAMP SELECTION: See page 127 for complete lamp selection.
 NOTE: Sealed beam lamp type available only in LRP (Par36) style.

ORDERING INFORMATION

Series	Head #	Voltage/Wattage	Options
SRP	1 (single head)	See Lamp Selection Guide	LC (less canopy)
	2 (double head)		B (black housing)
	3 (triple head)		

SRP BUILDER

Series	Head #	Voltage/Wattage	Options



LRP - PAR36 Large Style Emergency Remote

The **LRP** series of remotes are constructed of high impact thermoplastic and feature an innovative rotary locking collar design that securely locks the lens and reflector assembly into place. The locking collar allows maintenance personnel to quickly and easily complete relamping. A mechanically adjustable swivel locks the head in position once adjusted. The matching canopy fits nearly all standard electrical junction boxes. The **LRP** is supplied standard in a white color, black color is optional.

LAMP SELECTION: See page 127 for complete lamp selection
 NOTE: Sealed beam lamp type available only in LRP (Par36) style.

ORDERING INFORMATION

Series	Head #	Voltage/Wattage	Options
LRP	1 (single head)	See Lamp Selection Guide	LC (less canopy)
	2 (double head)		B (black housing)
	3 (triple head)		WP (weather proof) TC (teflon coated lens)

SRP BUILDER

Series	Head #	Voltage/Wattage	Options



BLT - MR16 Emergency Remote

The **BLT** series of emergency remote offers a contemporary design with a look that is not only architecturally pleasing, but also suits today's retro industrial designs. The **BLT** uses MR16 technology that is designed for premium light output. The **BLT** series is constructed of high grade steel with an attractive white, durable, powder coat finish as standard, and is available in single or double head configurations. Other colors are available, including color matching, please specify. The **BLT** is fully adjustable and the matching custom canopy fits nearly all standard electrical junction boxes.

ORDERING INFORMATION

Series	Head #	Voltage/Wattage	Options
BLT	1 (single head)	See Lamp Selection Guide	LC (less canopy)
	2 (double head)		CC (custom color)

BLT BUILDER

Series	Head #	Voltage/Wattage	Options



SRA - PAR36 Aluminum Emergency Remote

The **SRA** series of spun aluminum remotes are supplied standard in an attractive brushed aluminum finish with a black thermoplastic canopy. Custom colors available, please specify. The **SRA** series is ideal for industrial environments and installations where the fixture will be exposed to constant excessive temperatures or UV exposure.

LAMP SELECTION: (No sealed beam - only in LR PAR36 style heads) See page 127.

ORDERING INFORMATION

Series	Head #	Voltage/Wattage	Options
SRA	1 (single head)	See Lamp Selection Guide	LC (less canopy)
	2 (double head)		CC (custom color)
	3 (triple head)		TC (teflon coated lens)

SRA BUILDER

Series	Head #	Voltage/Wattage	Options



See lamp chart for more options.

NFR - Waeterh Proof Emergency Remote

The **NFR** series of NEMA 4X weather proof remotes are constructed of durable polycarbonate and designed to perform in harsh environments. The **NFR** series is fully gasketed and designed with several surface conduit knockout points.

LAMP SELECTION: See page 127

ORDERING INFORMATION

Series	Head #	Voltage/Wattage
NFR	1 (single head)	See Lamp Selection Guide
	2 (double head)	

NFR BUILDER

Series	Head #	Voltage/Wattage



See lamp chart for more options.

SRV Vandal Resistant Emergency Remote

The **SRV** series of remotes are constructed of high impact lexan that fully encloses and protects the lamp and reflector assembly from tampering or damage. The **SRV** series of remotes are ideally suited for high abuse areas.

LAMP SELECTION: See page 127 for complete lamp selection.

ORDERING INFORMATION

Series	Head #	Voltage/Wattage
SRV	1 (single head)	See Lamp Selection Guide
	2 (double head)	

SRV BUILDER

Series	Head #	Voltage/Wattage



SRE - PAR36 Recessed Emergency Remote

The **SRE** series of remotes are designed to be recess mounted into ceilings; providing a clean, unobtrusive lighting solution. A surface mounted version, complete with a steel mounting box is also available. The gimbal mounting allows the lamp aiming to be adjusted in any direction. The **SRE** is supplied standard in a white finish. Custom color finishes are available, please specify.

ORDERING INFORMATION

Series	Mount	Voltage/Wattage	Options
SRE	R (recessed)	See Lamp Selection Guide	CC (custom color)
	S (surface)		TC (teflon coated lens)

SRA BUILDER

Series	Head #	Voltage/Wattage	Options



RMR - MR16 Recessed Emergency Remote

The **RMR** series of remotes feature MR16 lamp technology that are designed for superior light output. The compact, recessed design has a modern look that blends perfectly in today's retail and commercial environments. The steel gimbal lamp mounting assembly and trim plate makes lamp positioning quick and easy. The **RMR** is supplied standard in white finish.

LAMP SELECTION:

6 VOLT	12 VOLT	24 VOLT	MR16:
5, 6, 10 W	10, 12, 20, 35, 50, 70, W20, 50W	LED	3, 5 W

ORDERING INFORMATION

Series	Voltage/Wattage
RMR	See Lamp Selection Guide

RMR BUILDER

Series	Voltage/Wattage

LUCE Ballast



LUCE - Emergency ballast

The **LUCE** series of emergency ballasts are designed to provide emergency illumination capability to existing or new fluorescent fixtures. **LUCE** series products consist of an internal nickel cadmium battery, charger and electronic circuit. A durable steel housing contains all components of the **LUCE** series. The **LUCE** series is available from 500 - 3000 lumens. The **LUCE** series is available for indoor, cold temperature, and damp location installations. Please consult Beghelli USA Customer Service for accurate installation specifications when ordering.

OPTIONS

Ballast Covers	-BC (contact factory)
Flex Conduit	-FX (please specific length)
Auto Test	- AT -luce-3, luce-4, luce-7

LUCE PLUS

If you are unable to locate the specific **LUCE** model to meet your requirements; please contact Beghelli USA Customer Service at 1-800-723-4316. Additional **LUCE** series products are available upon request. Proper specifications are required.

INSTALLATION

The **LUCE** series is suitable for new build and retrofit installations. Indoor, cold temperature and damp location models are available to be configured for installation on normally inflammable surfaces.

DIMENSIONS

Series	A	B	C
LUCE-1	9.4"	2.4"	1.5"
LUCE-2	9.4"	2.4"	1.5"
LUCE-3	13.3"	2.4"	1.5"
LUCE-4	16.3"	5.5"	1.7"
LUCE-5	9.5"	2.375"	1.5"
LUCE-6	9.5"	2.375"	1.5"
LUCE-7	9.5"	2.375"	1.5"
LUCE-8	17.5"	1.18"	1.15"
LUCE-9	21.5"	1.18"	1.15"

DIMENSIONS

Model	Lumens	# Lamps	Description
LUCE-1	500	1	2'-4' single, bi-pin T8-T12 linear fluorescent
LUCE-2	700	1, 2	2'-8' single, bi-pin T8-T12 linear fluorescent 2'-4' double, bi-pin T8-T12 linear fluorescent
LUCE-3	1400	1, 2	2'-8' single, bi-pin T8-T12 linear fluorescent 2'-4' double, bi-pin T8-T12 linear fluorescent
LUCE-4	3000	1, 2	2'-8' single, bi-pin T8-T12 linear fluorescent 2'-4' double, bi-pin T8-T12 linear fluorescent
LUCE-5	650	1, 2	7, 9, 12w twin tube, 2 pin CF 9-13w quad tube, 2 pin CF
LUCE-6	650	1	18-26w quad tube, 2 pin CF
LUCE-7	650	1	10-42w 4 pin rapid start CF
LUCE-8	825	1	2'-4' T5-T5HO linear, 40-55w 4 pin CF
LUCE-9	1300	1	2'-4' T5-T5HO linear, 40-55w 4 pin CF

EXAMPLE: LUCE-3

DESCRIPTION: LUCE emergency ballast, 1400 lumens.

WARRANTY

The **LUCE** Series comes with a 5-year factory warranty. Deliberate damage, misuse, improper installation effectively cancel the warranty.

PRODUCT OVERVIEW

The **FORZA1** series is a compact, modular emergency lighting inverter designed to supply emergency back-up for HID fixtures, quartz restrike, fluorescent, incandescent, and low voltage Life Safety products. The **FORZA1** is suitable for outdoor emergency egress lighting, medium size offices, and warehouses. The modular design and low MTTR ensure easy maintenance and field upgradeability.

STANDARD FEATURES

- PWM/MOSFET Inverter Technology for high efficiency and low THD
- UL924 listed and meets or exceeds the requirements of OSHA for emergency lighting and power. NFPA70, NFPA101, NFPA110, UBC, and SBCCI and New York City approved
- 97% efficient in standby mode means no fan for cooling
- Compatible with HID, fluorescent, incandescent, and electronic low voltage lighting
- Maintenance-free, sealed lead calcium valve regulated lead acid batteries
- Field upgradeable from 500VA to 2000VA by additional battery modules
- Microprocessor controlled, 2x20 character display with touch pad controls front panel interface
- Programmable set points are password controlled with user and service levels.

MECHANICAL SPECIFICATIONS

- Small footprint. Each unit measures 26"Wx10"Hx10"D
- Floor or wall mountable
- 16AWG steel constructed with powder coat surface
- Modular design allows separation of inverter and battery modules
- Electric knockouts for easy installation
- Breaker and Fuse access panel for easy routine maintenance

STANDARD ALARMS

- | | |
|--------------------|---------------------|
| - Output | - Inverter |
| - Charger | - Low Battery |
| - High Temp | - Load Reduction |
| - Overload | - Overload Shutdown |
| - Near Low Battery | - Low Voltage |
| - High Voltage | |

OPTIONS

- Circuit Breaker Trip Alarm
- Normal Off Output
- RS-232
- Summary Alarm Dry Contact
- Extended Runtime
- Remote Meter Panel
- Remote Summary Alarm Panel
- Multiple Voltages

*Additional enclosures may be required when ordering certain options.

DIAGNOSTIC FEATURES

- User programmable with password protection for alarms and diagnostics
- Self testing and diagnostic with event, test and alarm logs
- Standard Logs: Alarm log (75), Event log (75), Test log (50)

ELECTRICAL SPECIFICATIONS

Rating: 500-2000VA

Input: 120 or 277VAC, 2 wire plus ground, +10/-15%
60Hz, +/-3 Hz
1 Hz per second
Input circuit breaker

Output: 120 or 277VAC, 2 wire plus ground
2.8 = peak/rms current crest factor
<3% THD for linear load
60Hz +/- 25% load step change voltage regulation
Output circuit breaker

Battery: Sealed Lead Calcium VRLA
Battery circuit breaker protection
String voltage-48VDC for all models

Environmental: <10,000 feet without derating
20 to 30 degrees Celsius
-20 to 70 degrees Celsius (electronics only)
<95% (non-condensing)

Physical: Electronic Enclosure Dimensions=26"Wx10"Hx10"D
Weight=77LBS (35kg)
Battery Enclosure Dimensions=26"Wx10"Hx10"D
Weight=22LBS (10kg) per module w/o batteries

PRODUCT OVERVIEW

The **FORZA2** is a central inverter system designed to supply emergency back-up for HID fixtures, with quartz restrike, fluorescent, incandescent and low voltage Life Safety Products. It will support these loads at cold starts for all normally off circuits or regular normally on circuits. With self-diagnostics and over 120 parameters stored for test, event, and data logs, you are assured all NFPA codes are met. The **FORZA2** is also designed to function with the latest T5 & T5HO electronic ballasts. The **FORZA2** eliminates unit equipment in architecturally sensitive applications and reduces maintenance costs of individual testing. All tests and diagnostics are performed and recorded automatically.

STANDARD FEATURES

- Less than 15 minute MTTR.
- Pure PWM sine wave, less than 3% THD with 0.5 lead and 0.5 lag load capabilities. Microprocessor and crystal controlled.
- UL924 listed and meets or exceeds the requirements of OSHA for emergency lighting and power. NFPA70, NFPA101, NFPA110, UBC, and SBCCI and New York City approved.
- Compatible with HID, fluorescent, incandescent, and electronic low voltage lighting.
- Maintenance-free, sealed lead calcium valve regulated lead acid batteries.
- Selective models are upgradeable. Upgrades must be performed and programmed by authorized factory personnel.
- Self-testing per NFPA & UL standards. Memory logs of over 120 parameters contained in test, event and fault logs.
- Bonded fin heat sink for maximum thermal performance. Fan energized during inverter mode increases reliability and reduces preventative maintenance. No air filters required.

MECHANICAL SPECIFICATIONS

- System module is housed in a freestanding NEMA 1 enclosure.
- Small footprint (electronics) - up to 4.8kVA 25”(depth) x 30” (width). Dimensions will vary depending on configurations required.
- 14AWG steel constructed with powder coat surface.
- Hinged doors with security locks for easy maintenance.
- Standard battery cabinets are designed to allow stacking to minimize the overall footprint.
- Front access only shall be required for installation, adjustments and expedient servicing
- Maintenance Bypass permits maintenance personnel to easily bypass the inverter and connect to AC power, allowing routine maintenance.

SYSTEM DISPLAY FUNCTIONS

Meter Functions	Program Functions	Control Functions
AC Voltage Input	Set Date	Test and Event Log (75 logs)
AC Voltage Output	Set Time	Date, Time, Duration
AC current output	Set Month Test Date/Set Month Test Time	Output volt/Current
Battery voltage	Set Yearly Test Date/set Yearly Test Time	Ambient Temp
Battery current	Set Load Fault Reduction Setting	Alarm Log (50 logs)
VA output	Set Low Battery Alarm	Buzzer On/Off
Inverter Watts	Set Near Low Battery Alarm	
Ambient Temperature	Set Low AC Voltage Alarm	
System Days	Set High AC Voltage Alarm	
Inverter Minutes	Set Ambient Temperature Alarm	

MAINTENANCE CONTRACTS:

A complete offering of preventive and full-service maintenance contracts for both the inverter system and batteries shall be available. An extended warranty and preventive maintenance package shall be available. Factory-trained service personnel shall perform warranty and preventive maintenance service. A five-year maintenance contract option will include a unit start-up and site training.

SYSTEM OPTIONS

Output Circuit Breaker: Maximum output breakers available is 12 unsupervised (1-pole), 8 supervised (1-pole).

Output Trip Alarm: An audible and visual alarm activates when an output distribution circuit breaker is open or has tripped.

Fast Charge: This is a battery charger upgrade which decreases the time to recharge a fully discharged battery bank to a full charge. The recharge time is decreased from the standard 24hr period to a 12hr period.

Summary Form C Contacts: Form "C" contacts rated at 5 amps maximum at 250VAC/30VDC. Dry contacts will change state when any system alarm activates. Contacts change states with the following alarms: High/low battery charger fault, near low battery, low battery, load reduction fault, output overload, high/low AC input volts, high ambient temperature, inverter fault, and with optional output trip alarm.

Auto-Dialer: Automatically dials up to 4 user-programmable phone numbers upon any alarm conditions. Capable of leaving a user-programmable digital or audible message. A dedicated phone line is required.

BATTERY OPTIONS

S-Battery (Sealed Lead-Calcium) (Standard): A maintenance-free, valve regulated lead calcium battery. Constructed with a rugged polypropylene case. No special room ventilation required. 10-year designed life expectancy.

G-Battery (Sealed Lead-Calcium): A maintenance-free, long life, valve regulated lead calcium battery. Constructed with a polypropylene jar, which is installed in a modular steel tray to create its own enclosure. Does not require any special room ventilation. 20-year designed life expectancy.

N-Battery (Nickel-Cadmium): A minimum maintenance wet cell requiring addition of distilled water periodically. This battery type provides a wider operating range. Constructed with a translucent, heavy-duty polypropylene case. This case is marked with a high/low line to check electrolyte level. 25-year designed life expectancy.

ELECTRICAL SPECIFICATIONS

INPUT: Voltage - 120 or 277VAC 1-phase 2-wire +10% - 15%. Contact factory for all other voltages.

Input Power Walk-in - Limiting inrush current to less than 125%. 10 times for 1 line cycle.

Input Frequency - 60Hz, +/- 3%, 50Hz available upon request.

Synchronizing Slew Rate - 1Hz per second nominal.

Protection - Input Circuit Breaker.

Harmonic Distortion - <10%.

Power Factor - 0.5 lag/lead.

OUTPUT: Voltage - 120 or 277VAC 1-phase 2-wire. Contact factory for all other voltages.

Static Voltage - Load current change +/-2%, battery discharge +/-12.5%.

Dynamic Voltage - +/-2% for +/-25% load step change, +/-3% for a 50% load step change, recovery within 3 cycles.

Harmonic Distortion - <3% THD for linear load.

Output Frequency - 60Hz +/- 0.05Hz during emergency mode.

Load Power Factor - 0.5 lag to 0.5 load.

Inverter Overload -125% for 5 minutes.

Protection - Output Circuit Breakers (optional).

BATTERY: Type - Valve-regulated sealed lead-calcium.

Charger - Microprocessor controlled for various battery types and temperature compensating (recharge per UL924 spec).

Protection - Automatic low-battery disconnect, automatic restart upon utility return.

Disconnect - Fuse

Optional Runtimes - Extended runtimes available. See product selection guide.

*Battery module may be contained in external cabinet(s) depending on the system VA required.

CHARGER: The temp compensated battery charger supplies constant voltage & constant current to batteries.

- Charges batteries within 24hrs maximum with constant trickle charge to maintain batteries at maximum level.
- Provided with an AC input current limiting circuit whereby the maximum input current shall not exceed 125% of full output rating.
- Upon restoration of AC power, the system will automatically restart, performing the normal central system start up.
- Charger shall have an output filter to minimize AC ripple voltage into the battery. Ripple will not exceed 2% RMS.
- Charger is equipped with a DC over voltage protection circuit so that if the DC voltage rises above the pre-set limit, the charger is to shut down automatically and initiate an alarm condition.

ENVIRONMENTAL: Altitude - <10,000 feet (above sea level) without de-rating.

Operating Temperature - System operates safely from 0° to 40°C (32° to 104°F) up to 95% humidity. UL rating, 20° to 30°C (68° to 86°F), includes battery performance which can be affected by temperature.

Contact factory for details

Storage Temperature - (- 20° to 70°C electronics only).

Relative Humidity - <95% (non-condensing).

GENERAL: Design - Stand-by no break. PWM inverter type utilizing IGBT technology with 2Ms transfer time

Generator Input - Compatible with generators.

Control Panel - Microprocessor controlled 2x20 character display with touch pad controls & functions, 5 LED indicators & alarm.

Metering - Input & Output Voltage, Battery & Output Current, Output VA, Temperature, Inverter Wattage.

Alarms - High/Low Battery Charger Fault, Near Low Battery, Low Battery, Load Reduction Fault, Output Overload, High/Low AC Input Volts, High Ambient Temperature, Inverter Fault, Output Fault, Optional Circuit Breaker Trip.

Communications - RS-232 port (DB9) Programmable monthly and yearly testing (meets NFPA 101, Life Safety Code requirements).

Manual Maintenance Bypass - Optional internal or optional external without internal distribution breakers.

Alarm Contacts - Optional Summary Form "C" contacts.

Warranty - 1 year standard warranty includes all parts, labor, & travel expenses within 48 contiguous states. 10 years prorated warranty on batteries. Extended warranties, preventative maintenance and customized service plans are available.

Factory Start-Up - Purchase factory start-up & receive 1 additional year of electronics warranty.

5 Year Maintenance Plan - Purchase 5 year maintenance plan & receive free factory start-up.

5 Year Electronic Warranty - Purchase 5 year electronic warranty & receive free factory start-up.

PHYSICAL: Cabinet - Free-standing NEMA 1.

Cooling - Forced air, during emergency mode. Convection cooled during normal operation. No filters required.

Cable Entry - Top and side.

Access - Front only.

PRODCUT OVERVIEW

The **FORZA3** is a central inverter system designed to supply emergency back-up for HID fixtures, with quartz restrike, fluorescent, incandescent and low voltage Life Safety Products. It will support these loads at cold starts for all normally off circuits or regular normally on circuits. With self-diagnostics and over 120 parameters stored for test, event, and data logs, you are assured all NFPA codes are met. The **FORZA3** is also designed to function with the latest T5 & T5HO electronic ballasts. The **FORZA3** eliminates unit equipment in architecturally sensitive applications and reduces maintenance costs of individual testing. All tests and diagnostics are performed and recorded automatically.

STANDARD FEATURES

- Less than 15 minute MTTR.
- Pure PWM sine wave, less than 3% THD with 0.5 lead and 0.5 lag load capabilities. Microprocessor and crystal controlled.
- UL924 listed and meets or exceeds the requirements of OSHA for emergency lighting and power. NFPA70, NFPA101, NFPA110, UBC, and SBCCI and New York City approved.
- Compatible with HID, fluorescent, incandescent, and electronic low voltage lighting.
- Maintenance-free, sealed lead calcium valve regulated lead acid batteries.
- Selective models are upgradeable. Upgrades must be performed and programmed by authorized factory personnel
- Self-testing per NFPA & UL standards. Memory logs of over 120 parameters contained in test, event and fault logs.
- Bonded fin heat sink for maximum thermal performance. Fan energized during inverter mode increases reliability and reduces preventative maintenance. No air filters required.

MECHANICAL SPECIFICATIONS

- System module is housed in a freestanding NEMA 1 enclosure.
- Small footprint (electronics) - 4.8kVA-16.7kVA:25" (depth) x 30" (width) 24kVA-50kVA: 31" (depth) x 44" (width).
- 14AWG steel constructed with powder coat surface.
- Hinged doors with security locks for easy maintenance.
- Battery cabinets are designed to allow stacking to minimize the overall footprint.
- Front access only shall be required for installation, adjustments and expedient servicing.
- All components shall have a modular design and quick disconnect means to facilitate field service.
- Maintenance Bypass permits maintenance personnel to easily bypass the inverter and connect to AC power, allowing routine maintenance.

SYSTEM DISPLAY FUNCTIONS

Meter Functions	Program Functions	Control Functions
AC Voltage Input	Set Date	Test and Event Log (75 logs)
AC Voltage Output	Set Time	Date, Time, Duration
AC current output	Set Month Test Date/Set Month Test Time	Output volt/Current
Battery voltage	Set Yearly Test Date/set Yearly Test Time	Ambient Temp
Battery current	Set Load Fault Reduction Setting	Alarm Log (50 logs)
VA output	Set Low Battery Alarm	Buzzer On/Off
Inverter Watts	Set Near Low Battery Alarm	
Ambient Temperature	Set Low AC Voltage Alarm	
System Days	Set High AC Voltage Alarm	
Inverter Minutes	Set Ambient Temperature Alarm	

SYSTEM OPTIONS

Output Circuit Breaker: Maximum output breakers available: 4.8k up to 16.7k systems - 12 unsupervised (1-pole), 9 supervised (1-pole). 24k up to 50k systems - 24 unsupervised (1-pole), 16 supervised (1-pole). Combinations of 1, 2 and 3 pole breakers available (consult factory).

Output Trip Alarm: An audible and visual alarm activates when an output distribution circuit breaker is open or has tripped.

Fast Charge: This is a battery charger upgrade which decreases the time to recharge a fully discharged battery bank to a full charge. The recharge time is decreased from the standard 24hr period to a 12hr period.

Summary Form C Contacts: Form "C" contacts rated at 5 amps maximum at 250VAC/30VDC. Dry contacts will change state when any system alarm activates. Contacts change states with the following alarms: High/low battery charger fault, near low battery, low battery, load reduction fault, output overload, high/low AC input volts, high ambient temperature, inverter fault, and with optional output trip alarm.

Auto-Dialer: Automatically dials up to 4 user-programmable phone numbers upon any alarm conditions. Capable of leaving a user-programmable digital or audible message. A dedicated phone line is required

BATTERY OPTIONS

S-Battery (Sealed Lead-Calcium) (Standard): A maintenance-free, valve regulated lead calcium battery. Constructed with a rugged polypropylene case. No special room ventilation required. 10-year designed life expectancy.

G-Battery (Sealed Lead-Calcium): A maintenance-free, long life, valve regulated lead calcium battery. Constructed with a polypropylene jar, which is installed in a modular steel tray to create its own enclosure. Does not require any special room ventilation. 20-year designed life expectancy.

N-Battery (Nickel-Cadmium): A minimum maintenance wet cell requiring addition of distilled water periodically. This battery type provides a wider operating range. Constructed with a translucent, heavy-duty polypropylene case. This case is marked with a high/low line to check electrolyte level. 25-year designed life expectancy.

ELECTRICAL SPECIFICATIONS

INPUT: Voltage - 120/208 or 277/480VAC 3-phase 4-wire +10%-15% (Wye configuration).

Input Power Walk-in - Limiting inrush current to less than 125%. 10 times for 1 line cycle.

Input Frequency - 60Hz, +/- 3%.

Synchronizing Slew Rate - 1Hz per second nominal.

Protection - Input Circuit Breaker.

Harmonic Distortion - <10%.

Power Factor - 0.5 lag/lead.

OUTPUT: Voltage - 120/208 or 277/480VAC 3-phase 4 wire. (Wye or Delta configuration).

Static Voltage - Load current change +/-4%, battery discharge +/-4%.

Dynamic Voltage - +/-3% for +/-25% load step change, +/-6% for a 50% load step change, recovery within 3 cycles.

Harmonic Distortion - <3% THD for linear load.

Output Frequency - 60Hz +/- 0.05Hz during emergency mode.

Load Power Factor - 0.5 lag to 0.5 lead.

Inverter Overload - 115% for 5 minutes, 125% for 12 line cycles.

Protection - Output Circuit Breaker (optional).

BATTERY: Type - Valve-regulated sealed lead-calcium..

Charger - Microprocessor controlled for various battery types and temperature compensating (recharge per UL924 spec).

Protection - Automatic low-battery disconnect, automatic restart upon utility return.

Disconnect - Fuse (4.8 - 16.7kVA) and fuse/circuit breaker 24kVA and above.

Optional Runtimes - Extended runtimes available.

*Battery module may be contained in external cabinet(s) depending on the system VA required.

CHARGER: The temp compensated battery charger supplies constant voltage & constant current to batteries.

- Charges batteries within 24hrs maximum with constant trickle charge to maintain batteries at maximum level.
- Provided with an AC input current limiting circuit whereby the maximum input current shall not exceed 125% of full output rating.
- Upon restoration of AC power, the system will automatically restart, performing the normal central system start up.
- Charger shall have an output filter to minimize AC ripple voltage into the battery. Ripple will not exceed 2% RMS.
- Charger is equipped with a DC over voltage protection circuit so that if the DC voltage rises above the pre-set limit, the charger is to shut down automatically and initiate an alarm condition.

ENVIRONMENTAL: Altitude - <10,000 feet (above sea level) without de-rating.

Operating Temperature - 20° to 30°C.

Storage Temperature - (- 20° to 70°C electronics only).

Relative Humidity - <95% (non-condensing).

GENERAL: Design - Stand-by UPS, PWM inverter type utilizing IGBT technology with 2Ms transfer time.

Generator Input - Compatible with generators.

Control Panel - Microprocessor controlled 2x20 character display with touch pad controls & functions, 5 LED indicators & alarm.

Metering - Input & Output Voltage, Battery & Output Current, Output VA, Temperature, Inverter Wattage.

Alarms - High/Low Battery Charger Fault, Near Low Battery, Low Battery, Load Reduction Fault, Output Overload, High/Low AC Input Volts, High Ambient Temperature, Inverter Fault, Output Fault, Optional Circuit Breaker Trip.

Communications - RS-232 port (DB9) Programmable monthly and yearly testing (meets NFPA 101, Life Safety Code requirements).

Manual Maintenance Bypass - Standard (Internal).

Alarm Contacts - Optional Summary Form "C" contacts.

Warranty - 1 year standard warranty includes all parts, labor, & travel expenses within 48 contiguous states. 10 years pro-rated warranty on batteries. Extended warranties, preventative maintenance and customized service plans are available.

Factory Start-Up - Purchase factory start-up & receive 1 additional year of electronics warranty.

5 Year Maintenance Plan - Purchase 5 year maintenance plan & receive free factory start-up.

5 Year Electronic Warranty - Purchase 5 year electronic warranty & receive free factory start-up.

PHYSICAL: Cabinet - Free-standing NEMA 1.

Cooling - Forced air, during emergency mode. Convection cooled during normal operation. No filters required.

Cable Entry - Top and side on 4.8kVA - 16.7kVA; side only on 24kVA - 50kVA.

Access - Front only.

DIMENSIONS

STANDARD SYSTEM CONFIGURATIONS FOR 90 MINUTE BATTERIES

Series	Model Size	System Dimensions (standard)	Qty	Total System Weight (LBS)
FORZA-1	500W/VA	26"W x 10"H x 10"D	1	206
	1000W/VA	26"W x 10"H x 10"D	2	335
	1500W/VA	26"W x 10"H x 10"D	3	464
	2000W/VA	26"W x 10"H x 10"D	4	592
FORZA-2	1500W/VA	30"W x 47"H x 25"D	1	511
	2250W/VA	30"W x 47"H x 25"D	1	674
	3000W/VA	30"W x 47"H x 25"D	1	827
	3750W/VA	30"W x 47"H x 25"D	1	980
	4800W/VA	30"W x 47"H x 25"D	1	1168
	6000W/VA	60"W x 47"H x 25"D	2	1560
	8000W/VA	60"W x 47"H x 25"D	2	1965
	10000W/VA	60"W x 94"H x 25"D	3	2516
	12500W/VA	60"W x 94"H x 25"D	3	2980
	16700W/VA	60"W x 94"H x 25"D	3	3790
FORZA-3	4800W/VA	60"W x 47"H x 25"D	2	1633
	6000W/VA	60"W x 47"H x 25"D	2	1855
	8000W/VA	60"W x 47"H x 25"D	2	2247
	10000W/VA	60"W x 94"H x 25"D	3	2835
	12500W/VA	60"W x 94"H x 25"D	3	3279
	16700W/VA	60"W x 94"H x 25"D	3	4063
	24000W/VA	92"W x 72"H x 31"D	2	6390
	33000W/VA	140"W x 72"H x 31"D	3	8630
	40000W/VA	140"W x 72"H x 31"D	3	10,150
	50000W/VA	140"W x 72"H x 31"D	3	11,980

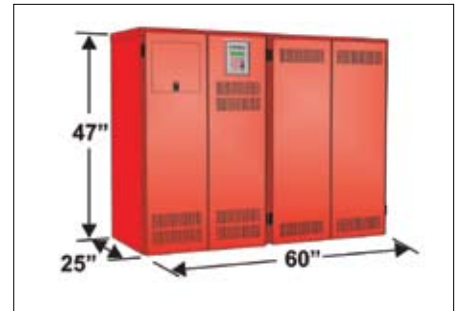

EXAMPLE - F21-C-6-S-BA0720-F-M-N-2YW

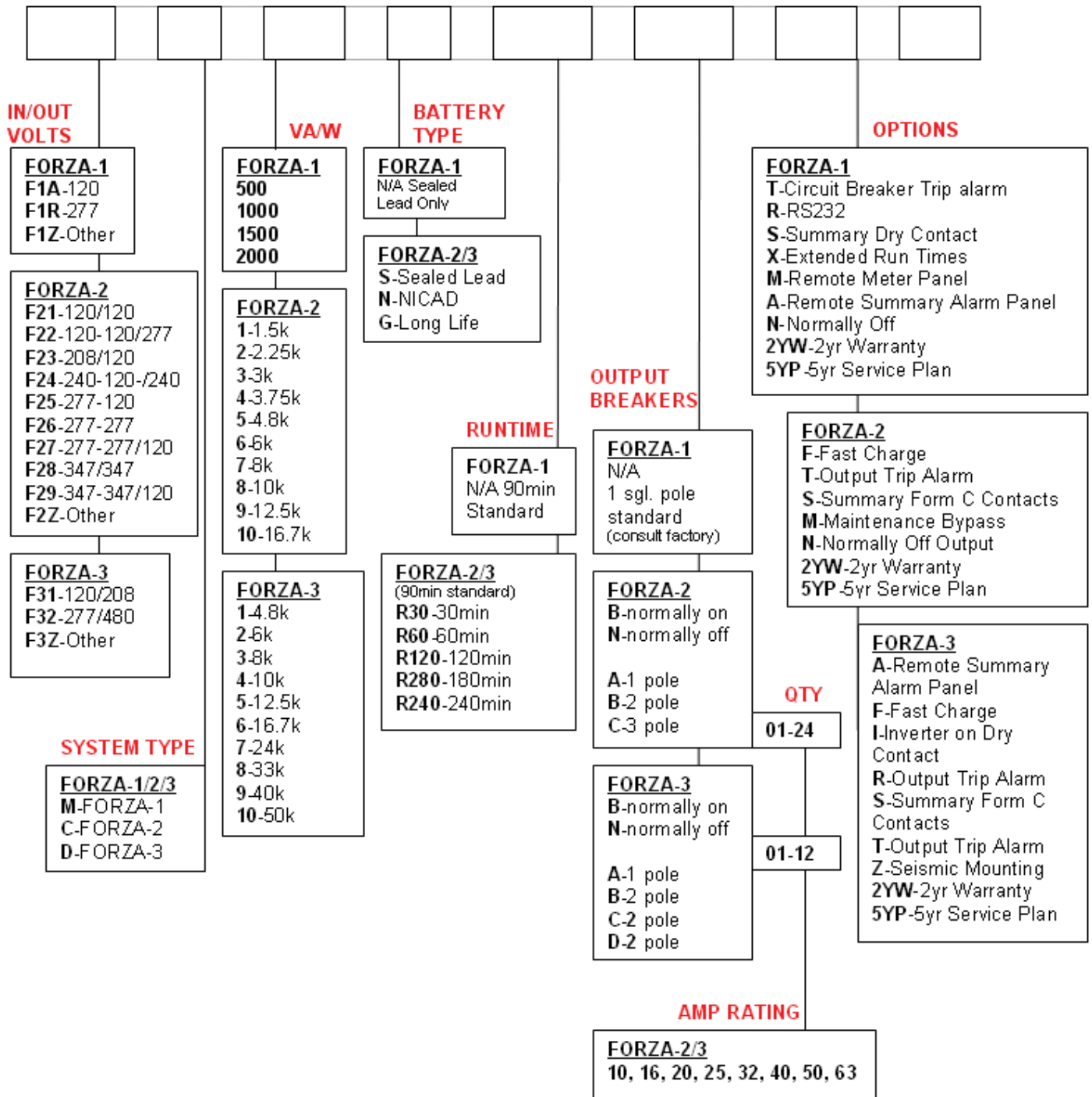

Please consult factory for more information

Accessories

SECTION EIGHT

MEMBERG



CONTENTS

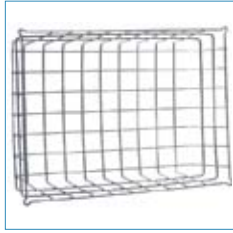

Wireguard & Mounting Shelves

Unit protection & mounting shelves	Page
Protective wire guards & mounting shelves for emergency & exit units	140



Custom Wording

Factory special wording	Page
Custom Wording and Graphics	141



Lamps

3W - 75W	Page
	142



Batteries

Replacement Batteries	Page
Batteries Specifically for Beghelli Products	143



Handheld

LED Torch Handheld	Page
High Performance LED Torch	144

WIREGUARDS & MOUNTING SHELVES

WIREGUARDS

Beghelli USA wireguards provide enhanced protection for emergency lighting equipment from physical damage. All are made from 18 gauge cold rolled steel and finished with a durable white (standard) baked powder coat finish for corrosion resistance. Color options are available upon request. Ideal for use in gymnasiums, outdoor installations, loading docks, warehouses, schools and apartment complexes.

ORDERING INFORMATION

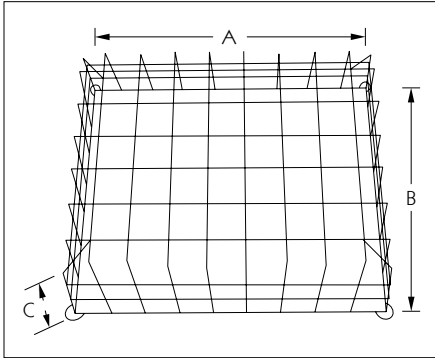

Model #	Application	Dimensions		
		A	B	C
BPG-1	combination exit & battery unit	17"	17"	17"
BGP-2	wall mount exit	14"	10"	4.5"
BPG-3	ceiling mount exits	14.5"	6"	10.5"
BPG-4	SRP1 and SPR2 remotes	6"	8"	6"
BPG-5	small cabinet battery units	15"	14"	6"
BPG-6	medium cabinet battery units	20"	17"	9"
BPG-7	large cabinet battery units	28.5"	24.75"	10"
BPG-8	SRP1 and LRP1 remotes	8"	6"	8"
BPG-9	SPR2 and LRP2 remotes	12"	9"	9"
BPG-10	ceiling mounted combination exit battery unit	13.5"	12"	16.5"
BPG-11	special wording custom size signs	29"	8"	10"
BPG-12	illumina 4' vapor tight	52"	9.25"	4.5"

MOUNTING SHELVES

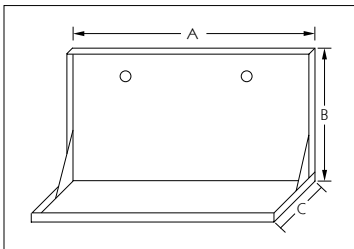

Model #	Application	Dimensions			
		A	B	C	
BMS-1	very small units	12W - 36 W	12"	10.5"	3.5"
BMS-2	small units:	54W - 72W	17"	10.5"	4.5"
BMS-4	medium units:	100W-200W	15"	13"	8.5"
BMS-5	large units:	300W-400W	19.5"	13"	8.5"

JOB:

TYPE:

CUSTOM WORDING

CUSTOM WORDING

The following wording and/or symbols are available for use in place of standard exit legends. Please consult factory for availability as well as other legends or symbols not shown. Most standard universal symbols are available, but due to space limitations are not able to be shown. For all custom wording or symbols, please specify letter color Red (R), Green (G) or White (W) on background color Red (R), Green (G) or White (W). All LED signs are available with Red (R) or Green (G) letters on White (W) background. For the BLACK OUT feature specify (BO) after the special wording (SW) option.

AUDIO HEARING
AREA OF REFUGE
AREA OF RESUE ASSISTANCE + Handicap Symbol
AREA FOR EVACUATION ASSISTANCE
BEAM ON
CAUTION RADIATION
CLOSED
CONTACT ROOM IN USE
DANGER
DANGER - DO NOT ENTER
DARK ROOM IN USE
DO NOT ENTER
DO NOT ENTER PIT WHEN LIT
DOWN ESCALATOR
EMERGENCY EXIT
EMERGENCY EXIT ONLY
EMERGENCY USE STAIRS
ENTRANCE
EXIT
EXIT - Arabic
EXIT - with arrow down
EXIT - with arrow up
FIRE DO NOT ENTER
FIRST AID
IN SESSION
IN USE
LASER IN USE
LASER RADIATION
LOBBY
MAGNET ON
MEN
NARCOTICS LOCKER OPEN
NO ENTRY
NO EXIT
NO SMOKING

NOT AN EXIT
OCCUPIED
ON AIR
ON THE AIR
OPEN
PLATING ROOM IN USE
PLEASE CLOSE DOOR
PROCEDURE IN PROGRESS
QUIET PLEASE
READIATION IN USE
RADITIAON ON
READY
RECORDING
RECORDING IN PROGRESS
RECORDING - NO ENTRY
REST ROOMS
ROOM IN SERVICE
SALIDA
SALIDA / EXIT
SIMULATOR IN USE
SORTIE
SORTIE / EXIT
STAIRS
STANDBY
STANDBY POWER
TELEPHON
TO EXIT
UP ESCALTOR
UV IN USE
UV RADIATION
WARNING - DO NOT ENTER - X-RAY IN USE
WARNING - DO NOT ENTER - EXAM IN PROGRESS
WOMEN
X-RAY IN USE
X-RAY IN USE - DO NOT ENTER
X-RAY ON

6V Lamps		12 V Lamps		24V Lamps	
LP-120	6V 3W (wedge base)	LP-106	12V 3.6W (wedge base)	LP-123	24V 9W (wedge base)
LP-101	6V 3.6W (wedge base)	LP-107	12V 5.4W (wedge base)	LP-323	24V 12W (bi-pin halogen)
LP-102	6V 5.4W (wedge base)	LP-108	12V 9W (wedge base)	LP-124	24V 18W (wedge base)
LP-103	6V 7.2W (wedge base)	LP-109	12V 12W (wedge base)	LP-310	24V 20W (bi pin halogen)
LP-104	6V 9W (wedge base)	LP-110	12V 18W (wedge base)	LP-421	24V 70W (H3 halogen)
LP-105	6V 12W (wedge base)	LP-112	12V 3W (wedge base)		
LP-201	6V 6W (sealed beam halogen)	LP-113	12V 14.4W (wedge base)		
LP-201-TC	6V 6W (sealed beam halogen teflon coated)	LP-211	12V 8W (sealed beam halogen)		
LP-202	6V 7.2W (sealed beam)	LP-212	12V 12W (sealed beam halogen)		
LP-203	6V 8W (sealed beam halogen)	LP-212-TC	12V 12W (sealed beam halogen teflon coated)		
LP-203-TC	6V 8W (sealed beam halogen teflon coated)	LP-213	12V 25W (sealed beam)		
LP-204	6V 9W (sealed beam)	LP-213-TC	12V 25W (sealed beam teflon coated)		
LP-204-TC	6V 9W (sealed beam teflon coated)	LP-214	12V 18W (sealed beam)		
LP-205	6V 10W (sealed beam halogen)	LP-215	12V 12W (sealed beam)		
LP-206	6V 12W (sealed beam)	LP-215-TC	12V 12W (sealed beam teflon coated)		
LP-206-TC	6V 12W (sealed beam halogen teflon coated)	LP-218	12V 30W (sealed beam)		
LP-207	6V 12W (sealed beam halogen)	LP-219	12V 35W (sealed beam)		
LP-207-TC	6V 12W (sealed beam teflon coated)	LP-220	12V 30W (sealed beam halogen)		
LP-208	6V 18W (sealed beam)	LP-306	12V 8W (bi-pin halogen)		
LP-208-TC	6V 18W (sealed beam teflon coated)	LP-300	12V 10W (bi-pin halogen)		
LP-209	6V 20W (sealed beam halogen)	LP-307	12V 12W (bi-pin halogen)		
LP-209-TC	6V 20W (sealed beam halogen teflon coated)	LP-308	12V 20W (bi-pin halogen)		
LP-210	6V 25W (sealed beam)	LP-309	12V 14W (bi-pin halogen)		
LP-210-TC	6V 25W (sealed beam teflon coated)	LP-151	12V 35W (bi-pin halogen)		
LP-216	6V 30W (sealed beam)	LP-224	12V 50W (sealed beam - wide flood)		
LP-221	6V 25W (sealed beam)	LP-350	12V 50W (bi-pin/T3 GY6.35)		
LP-222	6V 22W (sealed beam)	LP-355	12V 75W (bi-pin/T4 GY6.35)		
LP-301	6V 6W (bi-pin halogen)	LP-311	12V 55W (H3 halogen)		
LP-302	6V 8W (bi-pin halogen)	LP-410	12V 9W (DCB)		
LP-303	6V 10W (bi-pin halogen)	LP-411	12V 18W (DCB)		
LP-304	6V 12W (bi-pin halogen)	LP-412	12V 22W (DCB)		
LP-305	6V 20W (bi-pin halogen)	LP-413	12V 36W (DCB)		
LP-403	6V 9W (DCB)	LP-414	12V 16W (DCB)		
LP-405	6V 12W (DCB)	LP-415	12V 23W (DCB)		
LP-406	6V 18W (DCB)	LP-416	12V 8W (DCB)		
LP-407	6V 22W (DCB)	LP-432	12V 12W (DCB)		
LP-408	6V 6W (DCB)	LP-450	12V 2W (DCB)		
LP-409	6V 5W (DCB)				

Reference for replacement of emergency lighting batteries

Article No:	Operates Units	No of batteries:	Dimensions (of each single battery)
BP4.5-6 T1	6V 12W	1	2.76"L x 1.9"W x 4.21"H
BP7-6 T1	6V 18W	1	5.94"L x 1.34"W x 3.94"H
BP12-6 T1	6V 27W	1	5.94"L x 1.97"W x 3.94"H
BP7-6 T1	6V 36W	2	5.94"L x 1.34"W x 3.94"H
BP7-12 T1	12V 36W	1	5.57"L x 2.50"W x 3.75"H
BP12-6 T1	6V 54W	2	5.94"L x 1.97"W x 3.94"H
BP12-6 T1	12V 54W	2	5.94"L x 1.97"W x 3.94"H
BP12-6 T1	6V 72W	2	5.57"L x 2.50"W x 3.75"H
BP7-12 T1	12V 72W	2	5.94"L x 1.97"W x 3.94"H
BP12-6 T1	6V 100W	3	5.94"L x 1.97"W x 3.94"H
BP12-6 T1	12V 100W	4	5.94"L x 1.97"W x 3.94"H
BP12-6 T1	6V 125W	4	5.94"L x 1.97"W x 3.94"H
BP12-6 T1	12V 125W	4	7.68"L x 5.08"W x 7.05"H
BP33-12 T1	12V 150W	1	5.94"L x 1.34"W x 3.94"H
BP33-12 T1	12V 200W	1	5.94"L x 1.34"W x 3.94"H
BP33-12 T1	12V 300W	2	5.94"L x 1.34"W x 3.94"H
BP33-12 T1	12V 400W	2	5.94"L x 1.34"W x 3.94"H
BP33-12 T1	24V 200W	2	5.94"L x 1.34"W x 3.94"H
BP33-12 T1	24V 300W	2	5.94"L x 1.34"W x 3.94"H
BP33-12 T1	24V 400W	2	5.94"L x 1.34"W x 3.94"H

In order to choose the right replacement battery, just find the voltage and wattage of the emergency unit on the table above, the left column will tell you the battery number and the right column will tell you how many batteries you need for that specific fixture, plus their THD (total height dimensions).

Example: For a 6volt 36watt unit, you would need to order two (2) BP7-6 T1 batteries with the dimension 5.94"L x 1.34"W x 3.94"H each.



PRODUCT OVERVIEW

The **TORCH** by Beghelli is an aluminum compact flashlight, designed with an innovative, single high-output white LED, that provides intense light output and focus. Powered by 2xAA batteries, the **TORCH** has a constant run time of 25 hours and an LED life of 11 years. Incredibly durable and waterproof, the **TORCH** is a great partner to have.

ORDERING INFORMATION

Series	Description
8919	red, high intensity 1w LED
8915	blue, high intensity 1 w LED
8921	green, high intensity 1w LED
8917	gold, high intensity 1w LED

Technical

Technical Data

SECTION NINE

MEMBERGENT

CONTENTS

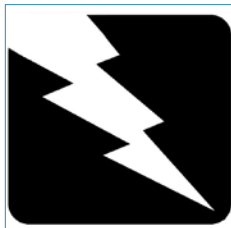

Voltage Drop Table

6v, 12v, 24v, 32v maximum voltage drop	Page
Voltage drop for most common emergency lighting voltages.	151

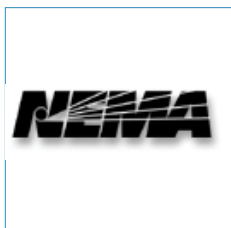

IEC Enclosure IP/NEMA

IP/NEMA	Page
International Standard for enclosure protection ratings	152

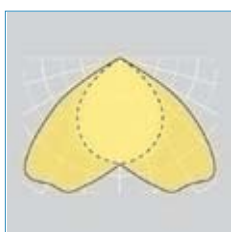

Photometric Data

Beghelli Photometric Calculations	Page
Photometric calculation files for Beghelli products & lamps.	154

VOLTAGE DROP TABLES

6 volts maximum voltage drop 5% per National Electric Code - wiring distance in feet

Wire Size	Watts	4	6	8	10	12	13	16	18	20	24	25	28	35	44	50	75	100	150	200	250	
#12		111	89	67	53	45	41	33	30	27	22	21	19	15	12	11	8	6	4			
#10		177	141	106	85	71	65	53	47	42	35	32	30	24	19	17	11	9	6			
#8		281	225	106	135	113	110	84	75	68	56	54	48	39	31	27	18	14	9	7		
#6		447	358	268	215	179	165	134	120	107	89	86	77	62	49	43	29	22	15	11	9	

12 volts maximum voltage drop 5% per National Electric Code - wiring distance in feet

Wire Size	Watts	4	8	12	13	16	18	24	25	28	35	44	50	75	100	150	200	250	300
#12		534	267	178	165	134	110	89	85	76	61	49	42	29	21	14	10	8	4
#10		849	425	283	260	212	190	142	136	121	97	77	68	45	34	23	17	14	11
#8		1351	675	450	415	338	300	225	215	193	154	123	108	72	54	36	27	21	18
#6		2148	1073	716	660	537	485	358	340	307	245	195	170	114	86	57	43	34	28

24 volts maximum voltage drop 5% per National Electric Code - wiring distance in feet

Wire Size	Watts	13	18	25	28	35	44	50	75	100	150	200	250	300	400
#12		660	440	340	305	244	194	168	116	84	56	40	32	26	21
#10		1040	760	544	485	388	309	272	180	136	92	68	52	44	34
#8		1668	1200	860	772	616	491	432	288	216	144	108	84	72	54
#6		2640	1900	1360	1227	980	781	650	456	344	228	172	136	112	85

32 volts maximum voltage drop 5% per National Electric Code - wiring distance in feet

Wire Size	Watts	13	18	25	28	35	44	50	75	100	150	200	250	300	400
#12		1170	840	600	543	435	345	300	200	150	100	75	60	50	42
#10		-	1340	960	863	690	549	480	320	240	160	120	86	80	63
#8		-	-	1540	1372	1100	873	770	510	385	255	192	154	128	100
#6		-	-	-	2180	1740	1388	1220	815	610	405	305	240	200	163

Formulas:

$$CM = \frac{22 \times W \times L}{.05 \times E^2}$$

$$L = \frac{CM \times .05 \times E^2}{22 \times W}$$

- CM = Wire size in circular mills
- W = Emergency loads in watts
- AWG = AMP Capacity C/M
- L = Length of circuit in feet
- E = Line voltage
- 22 = Constant
- .05 = Factor for maximum allowable voltage drop

Circular Mill Chart

AWG	AMP Capacity	C/M
12	20	6530
10	25	10,380
8	30	16,510
6	50	26,250

IEC 60529-10 & NEMA STANDARDS

ENCLOSURE PROTECTION RATING SYSTEM

The International Electrotechnical Commission (IEC) has established an enclosure grading system that produces an IP rating. Many Beghelli products are rated in accordance with the IEC standards and display the IP rating they have achieved. The IP rating is quickly becoming a critical element for emergency lighting fixtures. Since emergency lighting fixtures are typically mounted in close proximity to sprinkler heads (for example wall mounted battery units along a corridor), the potential of water related damage arising from activated or damaged sprinkler heads is an important consideration.

Provided below are IP / NEMA rating charts. These are designed to show the correlation of the IP and NEMA rating systems. **IMPORTANT:** NEMA claims that because IEC 60529-1 does not specify protection against corrosion, rust, oil or coolants, a direct correlation between the standards cannot be made. Because the NEMA rating meets or exceeds the corresponding IP rating, you can only translate NEMA to IP, not IP to NEMA.

The following table outlines the IP system of enclosure ratings.

First IP Numeral	
0	No Protection
1	Protection against solid objects up to 50mm, (accidental touch by hands)
2	Protection against solid objects up to 12mm, (fingers)
3	Protection against solid objects over 2.5mm, (tools & wires)
4	Protected against solid objects over 1mm.
5	Protection against dust, (limited ingress, no harmful deposit).
6	Protection against live or moving parts, including dust

Second IP Numeral	
0	No Protection
1	Protection against vertically falling drops of water, (condensation)
2	Protection against direct sprays of water up to 15 degrees from vertical
3	Protection against sprays up to 60 degrees from vertical.
4	Protection against water sprayed from all directions, (limited ingress permitted)
5	Protection against low pressure jets of water from all directions, (limited ingress permitted)
6	Protection against strong jets of water from all directions.
7	Protection against the effects of immersion between 15cm and 1m.
8	Protection against long periods of immersion under pressure.

**COMPARISON OF SPECIAL APPLICATIONS OF ENCLOSURES
FOR NON-HAZARDOUS LOCATIONS**

**Provides a degree of Protection Against the
Following Environmental Conditions**

Types of Enclosures

	1*	2*	4	4x	5	6	6P	12	12K	13
Incidental contact with the enclosed equipment	X	X	X	X	X	X	X	X	X	X
Falling Dust	X	X	X	X	X	X	X	X	X	X
Falling Liquid and light splashing	-	X	X	-	X	X	X	X	X	X
Circulating dust, lint, fibers and flyings**	-	-	X	X						X
Settling airbourne dust, line, fibers and flyings**	-	-	X	X						X
Hosedown and splashing water	-	-	-	X						X
Oil and coolant seepage	-	-	-	-						X
Oil or coolant spraying and splashing	-	-	-	-						X
Corrosive agents	-	-	-	-						X
Occasional temporary submersion	-	-	-	X						X
Occasional prolonged submersion	-	-	-	-						-

**Provides a degree of Protection Against the
Following Environmental Conditions**

Types of Enclosures

	3	3R+	3S	4	4X	6	6P
Incidental contact with the enclosed equipment	X	X	X	X	X	X	X
Rain, snow, sleet*	X	X	X	X	X	X	X
Sleet**	-	-	X	-	-	-	-
Windblown dust	X	-	X	X	X	X	X
Hosedown	-	-	-	X	X	X	X
Corrosive agents	-	-	-	-	X	-	X
Occasional temporary submersion	-	-	-	-	-	X	X
Occasional prolonged submersion	-	-	-	-	-	-	X

LAMP PHOTOMETRICS

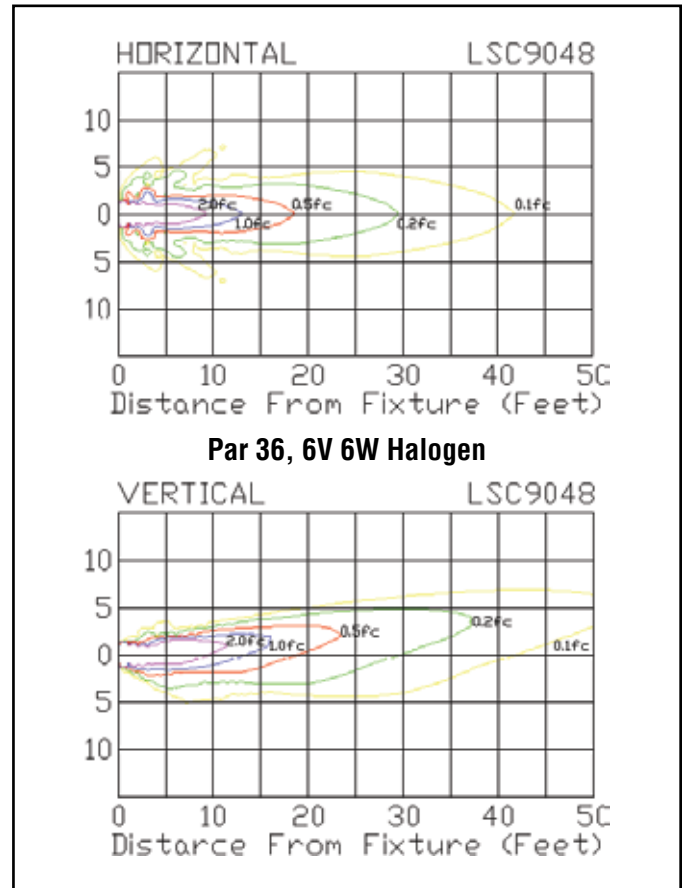
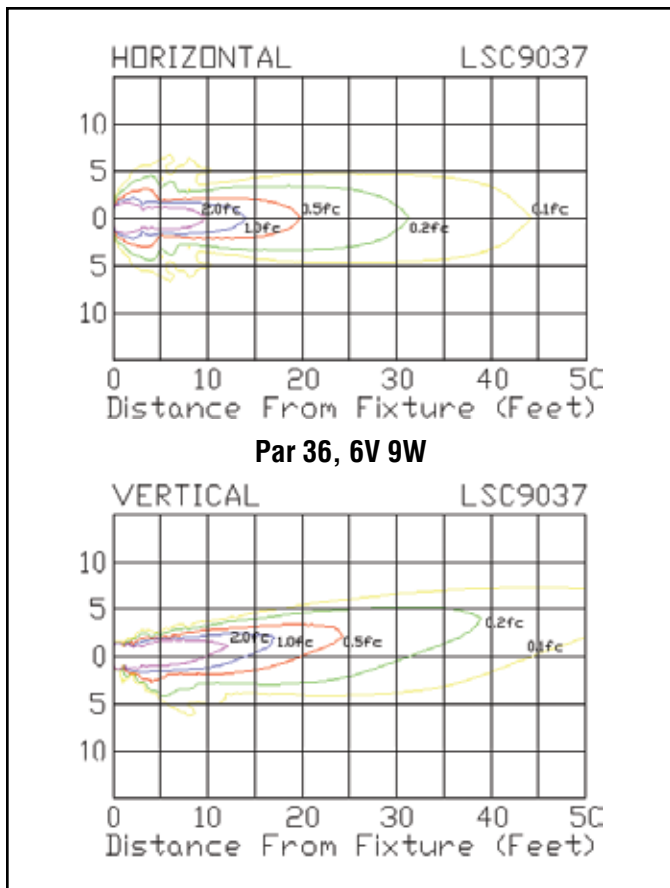
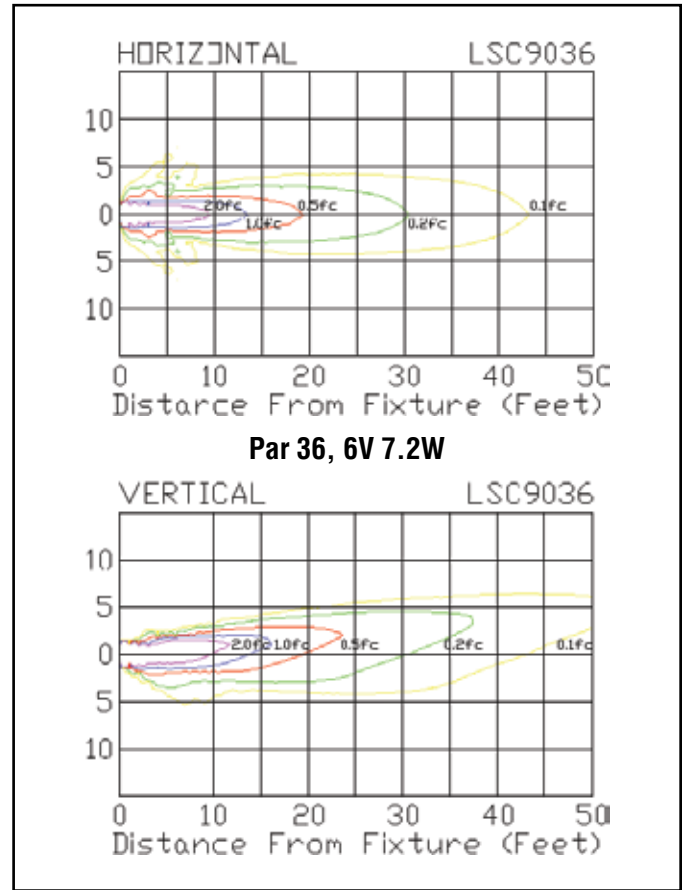
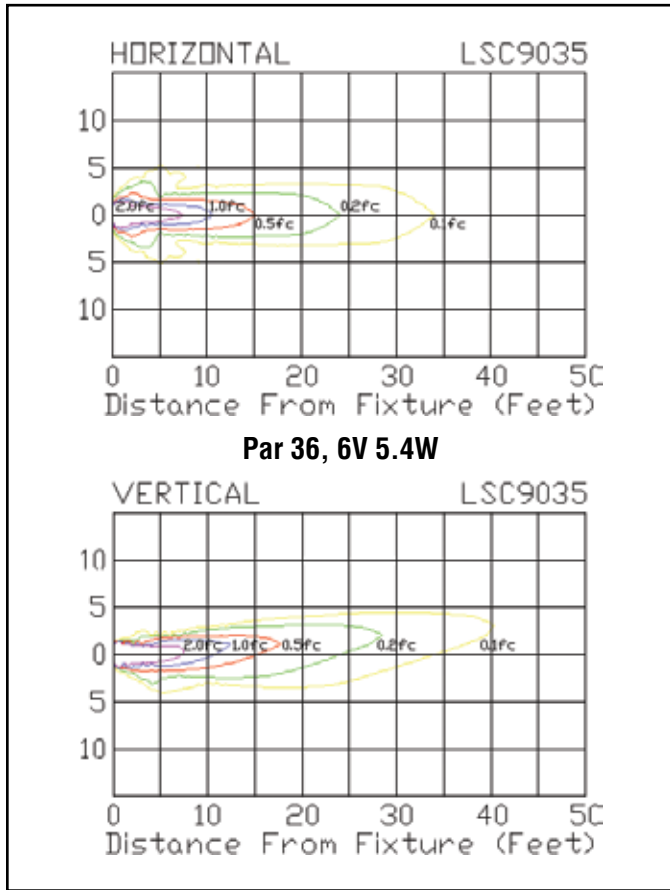

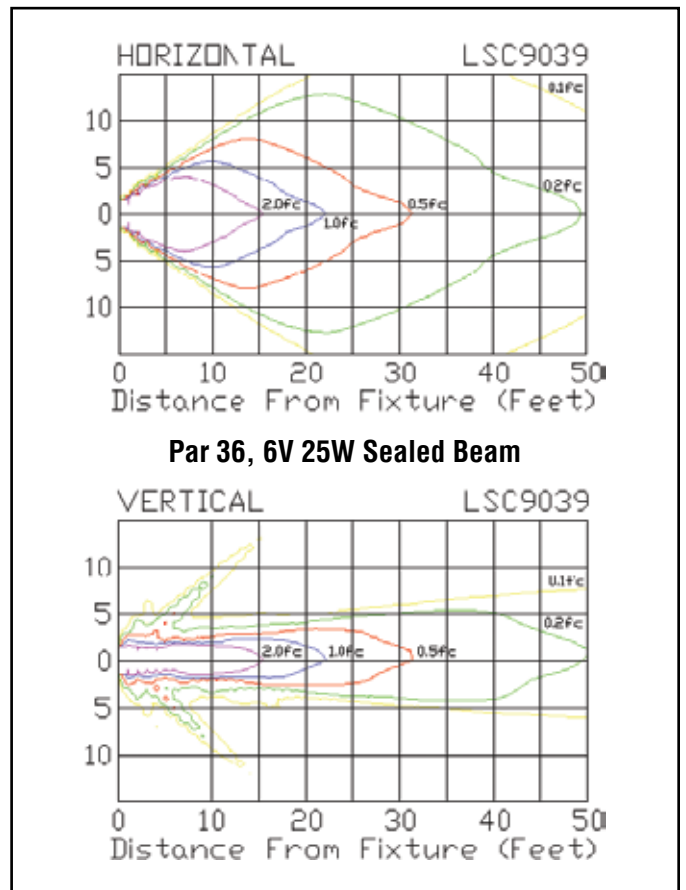
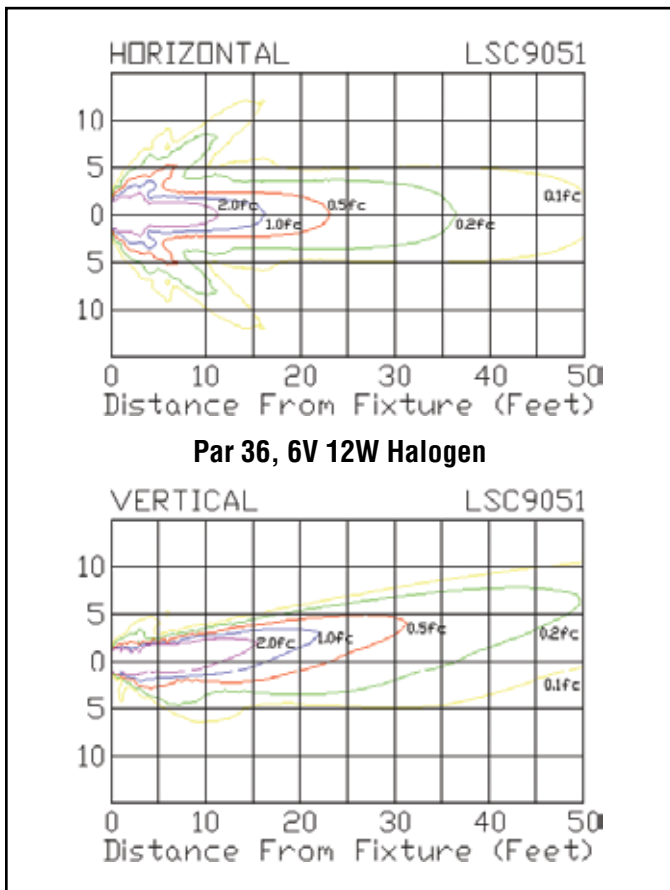
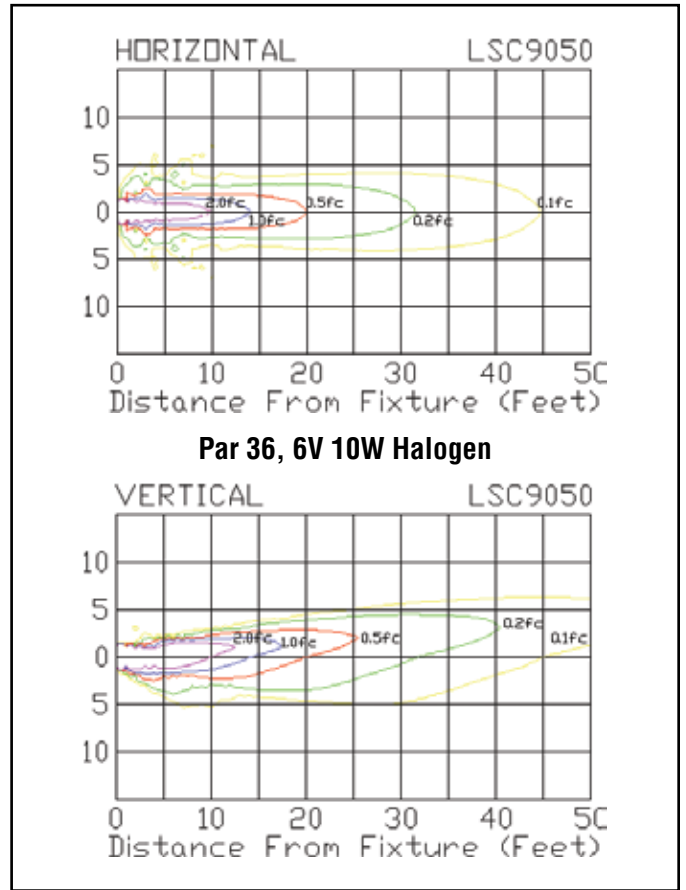
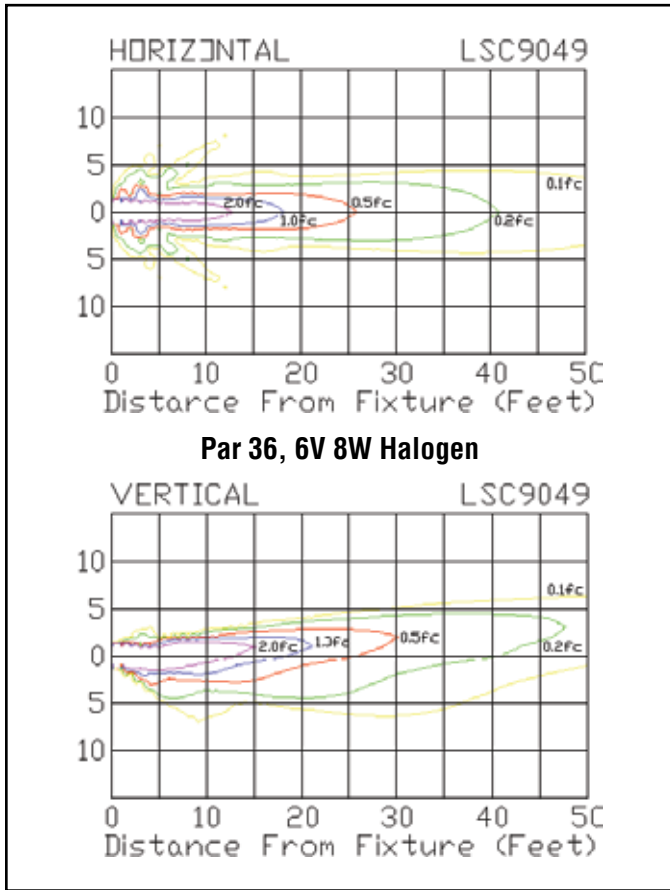

LAMP PHOTOMETRICS

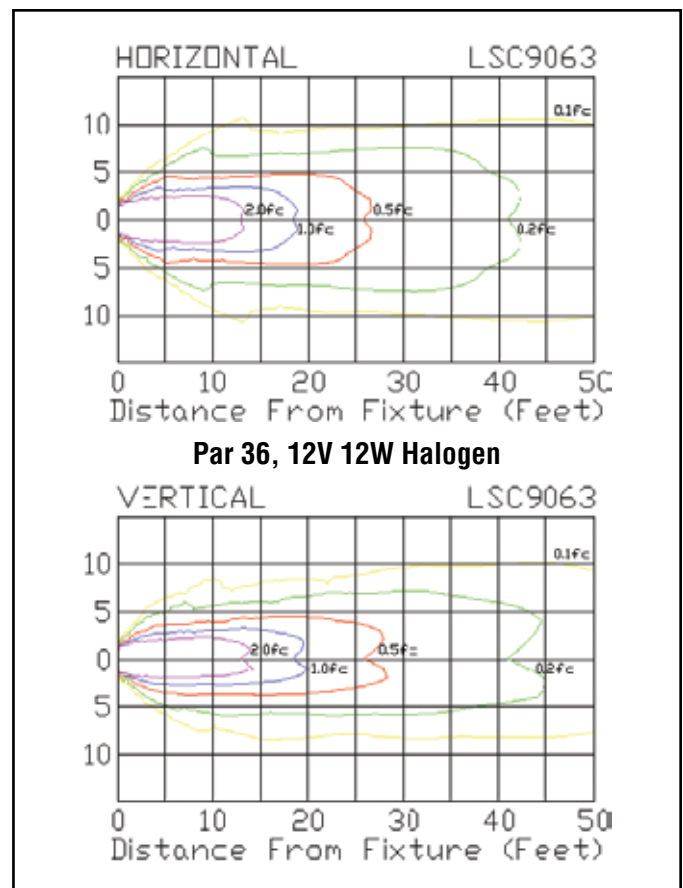
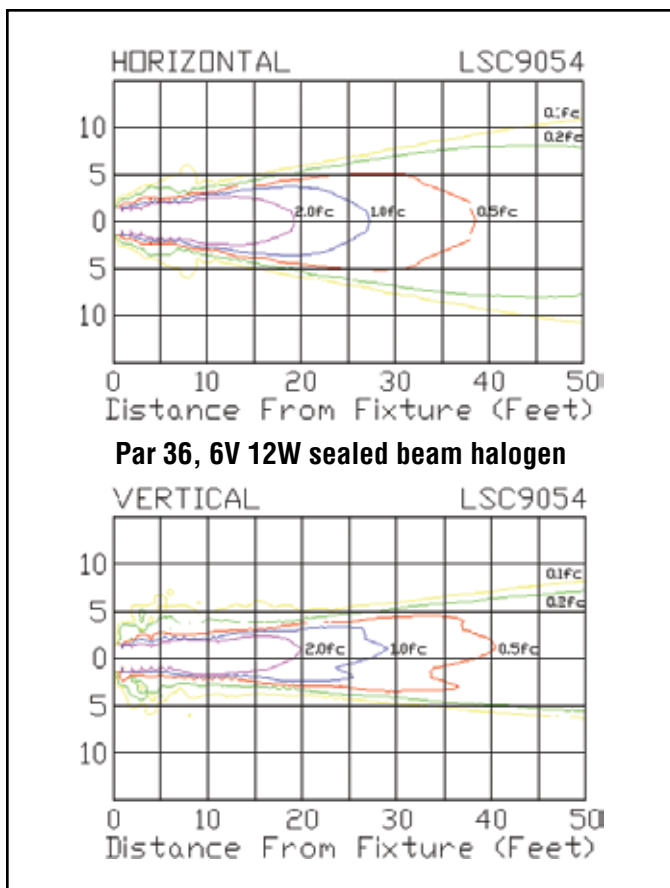
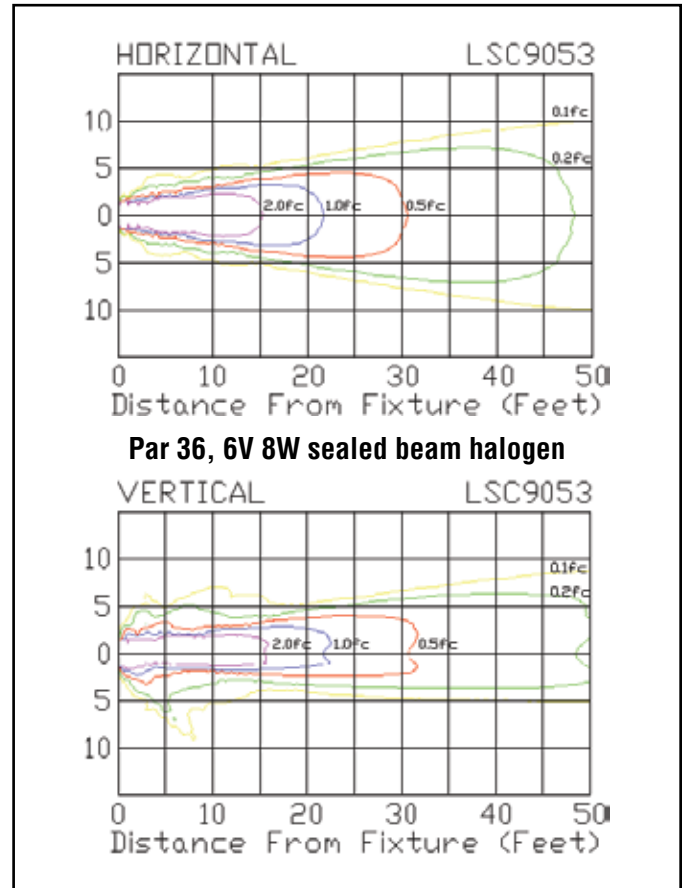
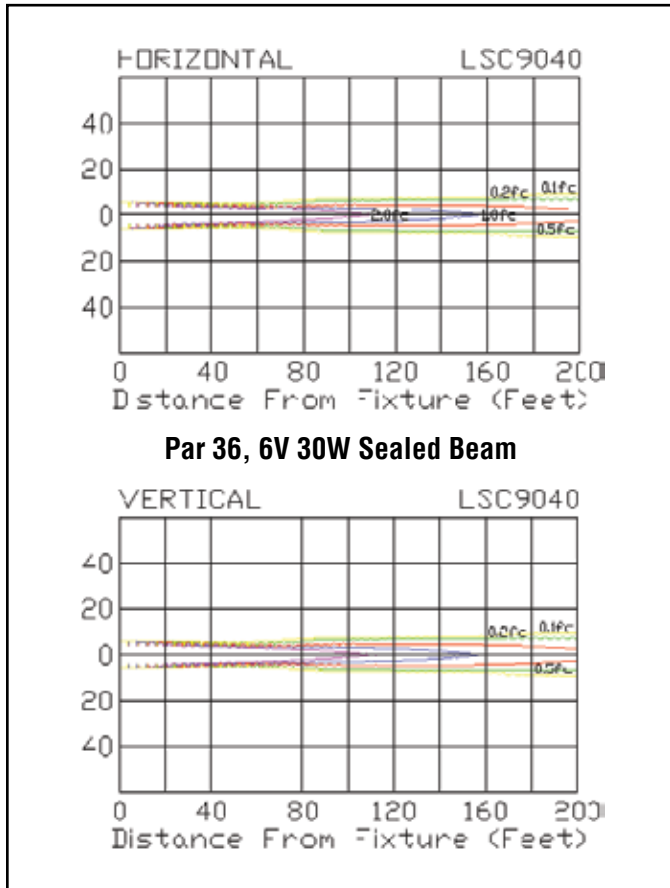

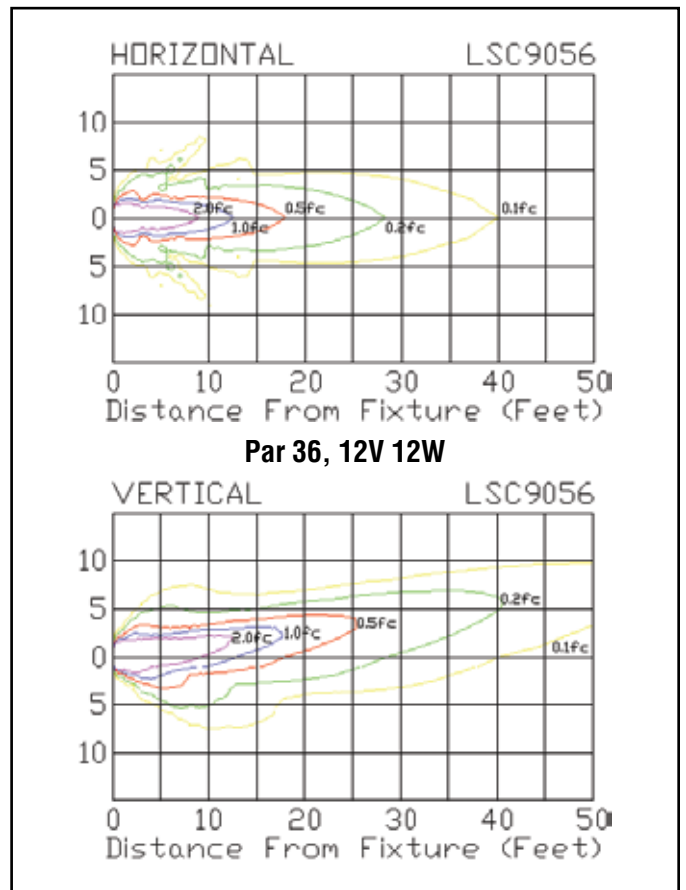
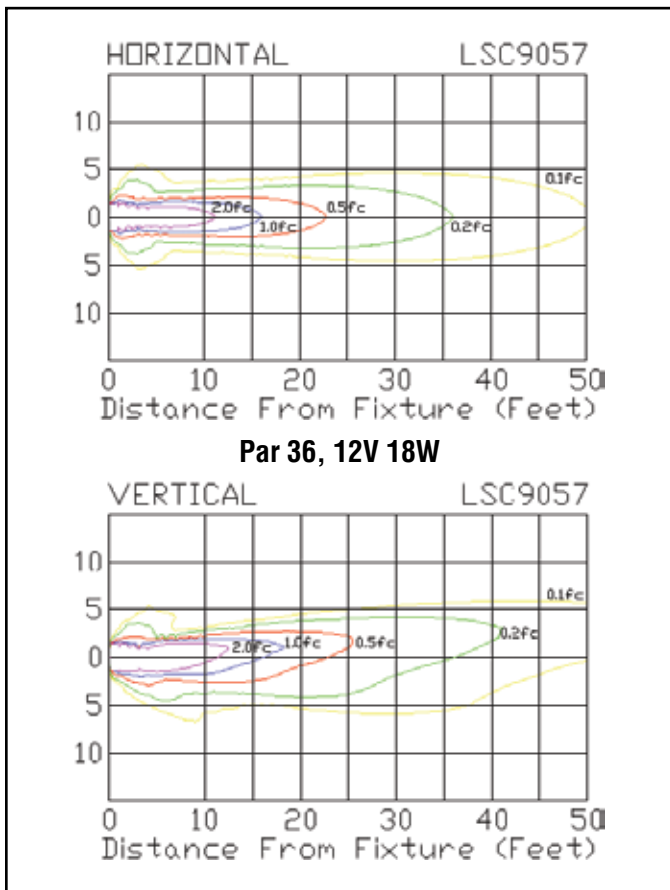
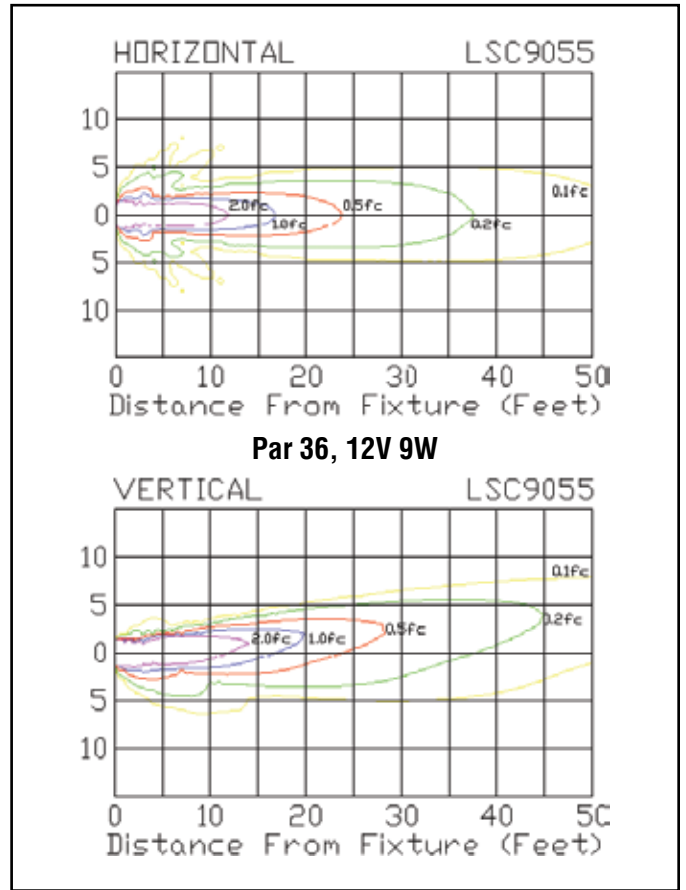
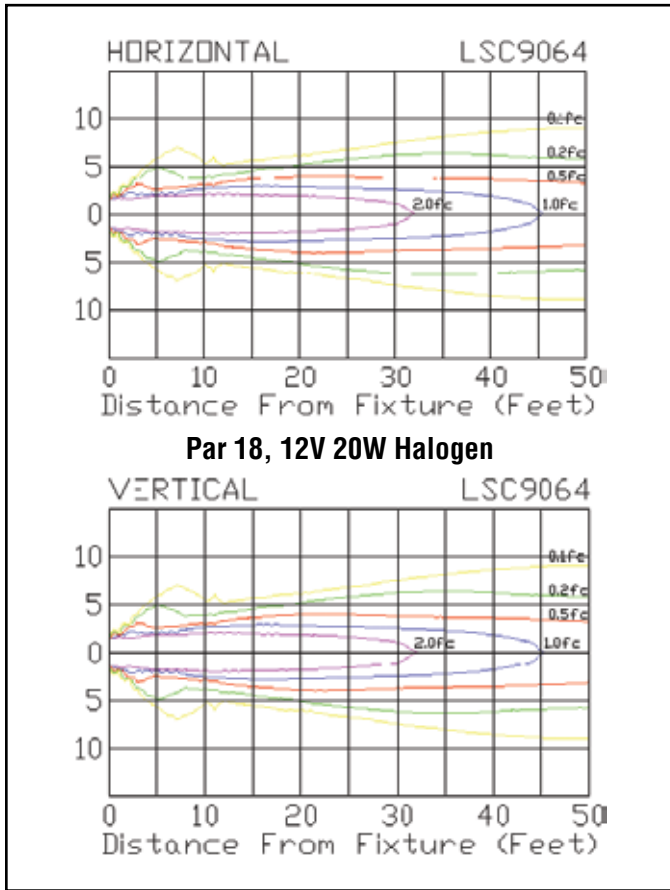

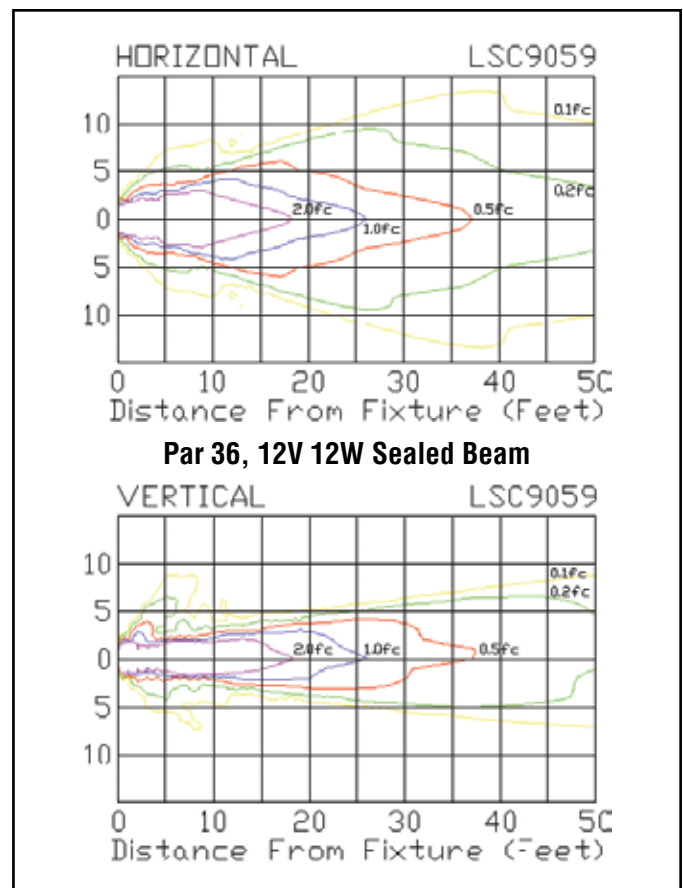
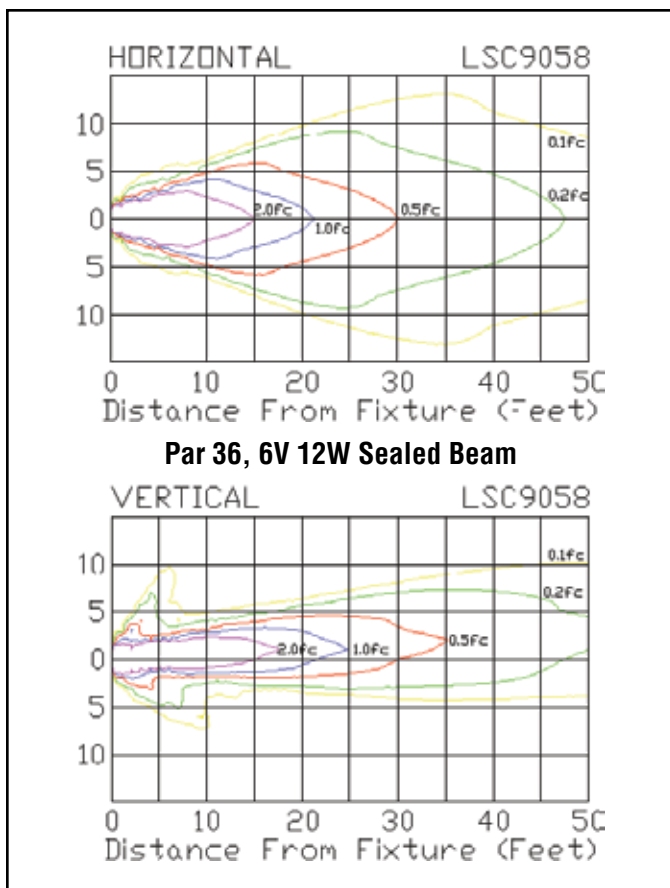
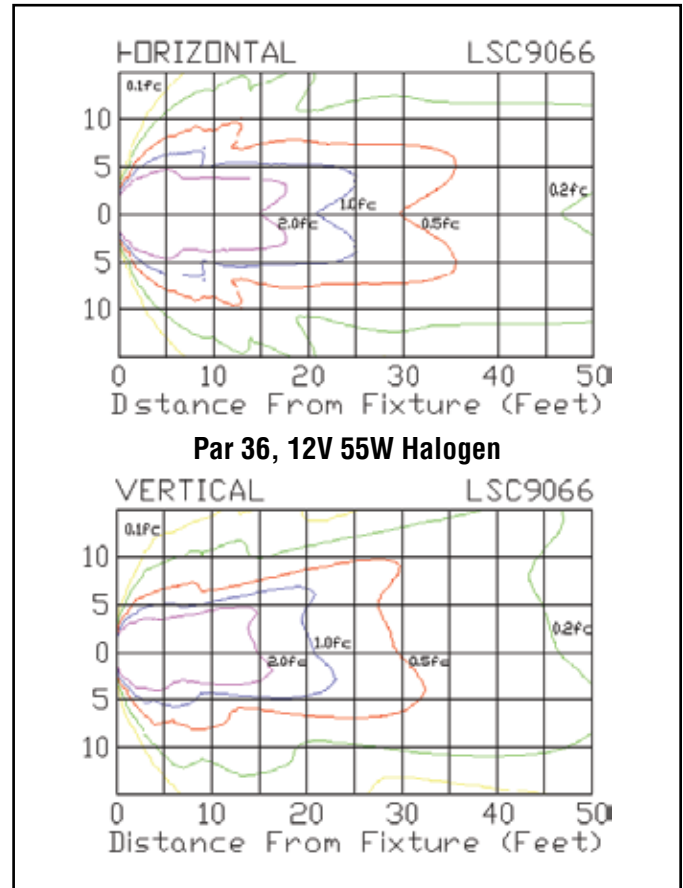
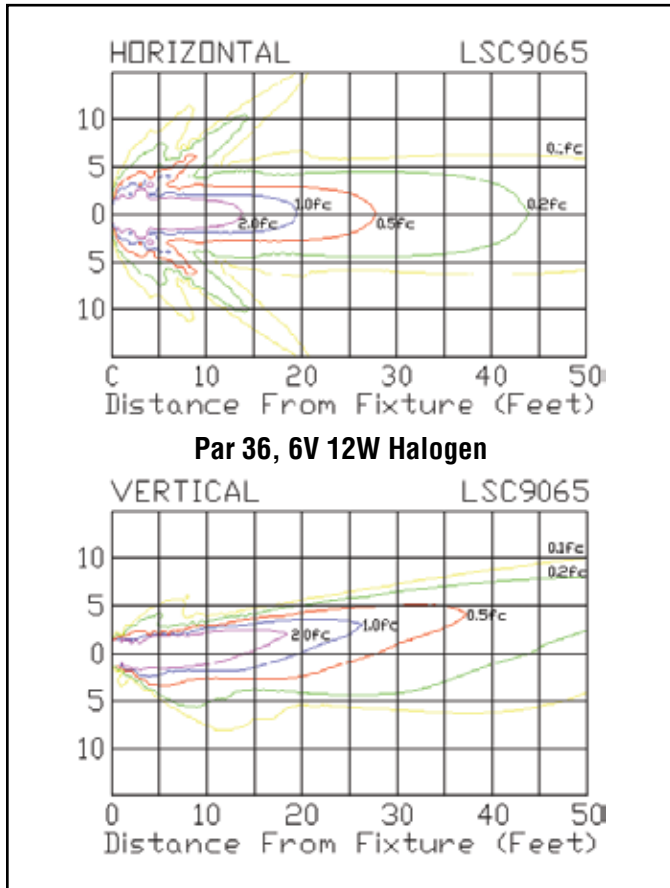

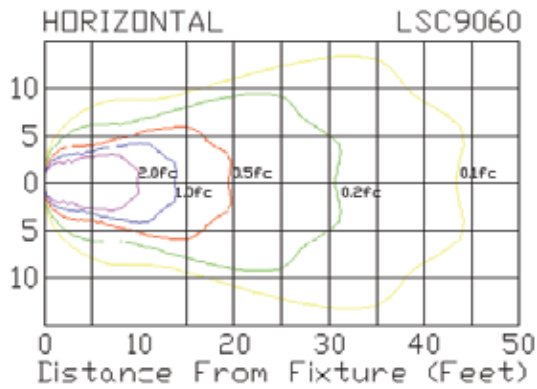

Par 36, 12V 25W Sealed Beam

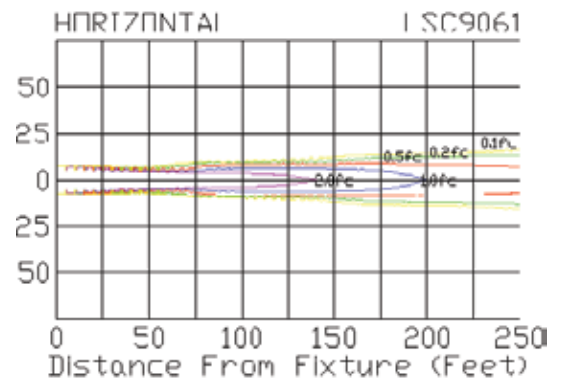
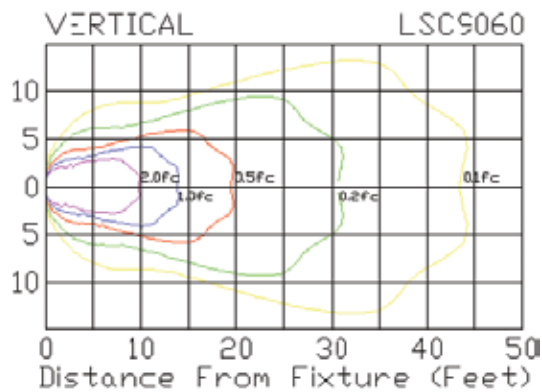

Par 36, 12V 30W Sealed Beam

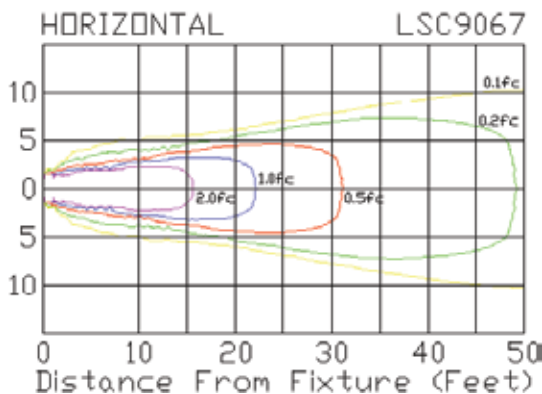
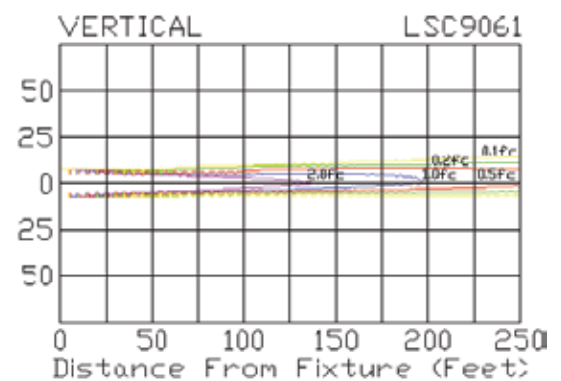

Par 36, 12V 8W Sealed Beam Halogen

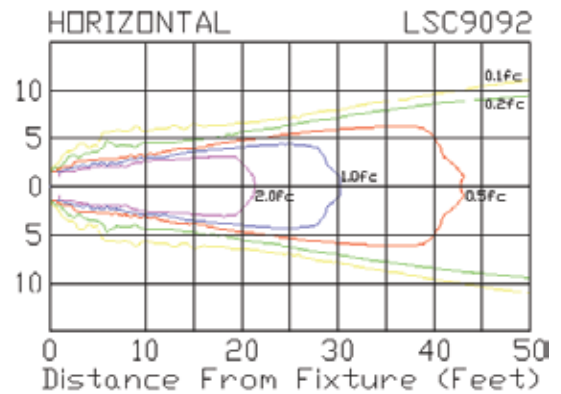
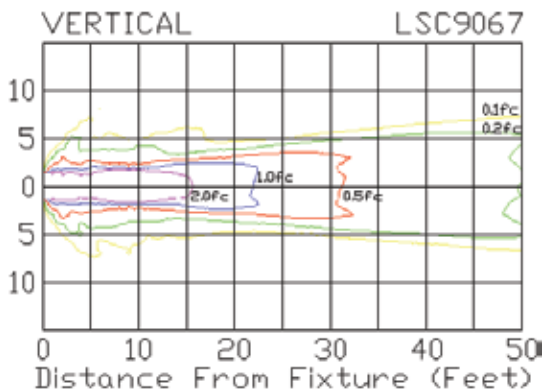

Par 36, 12V 12W Sealed Beam Halogen

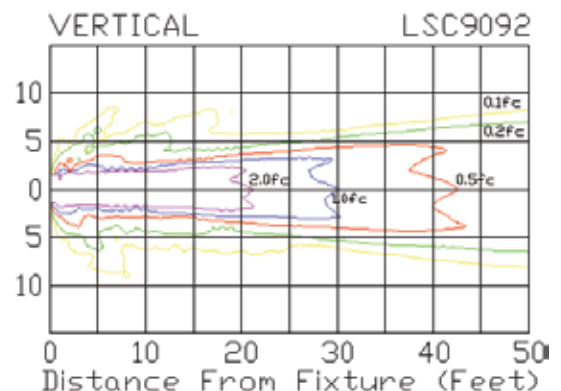

LAMP PHOTOMETRICS

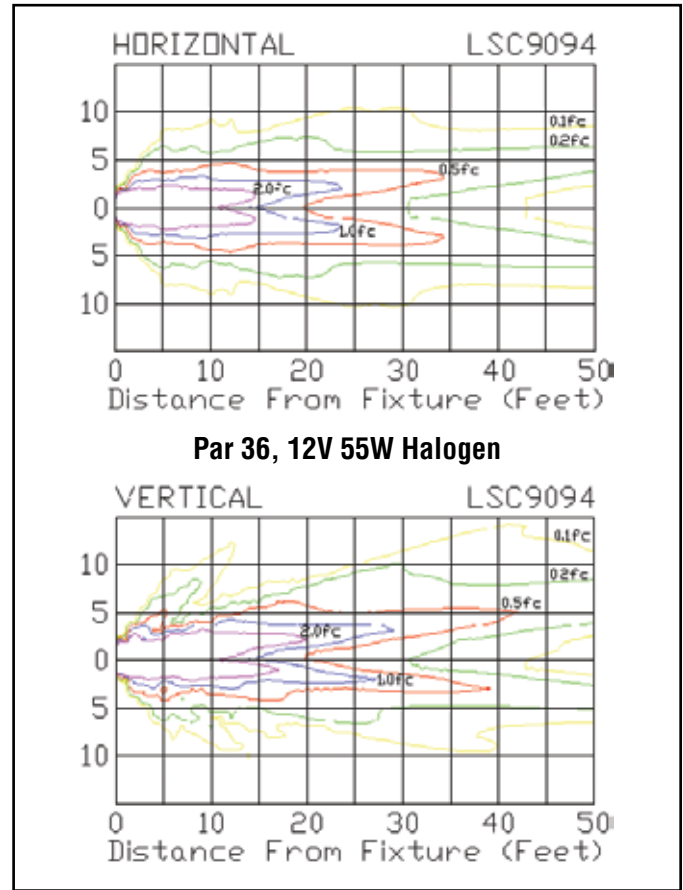
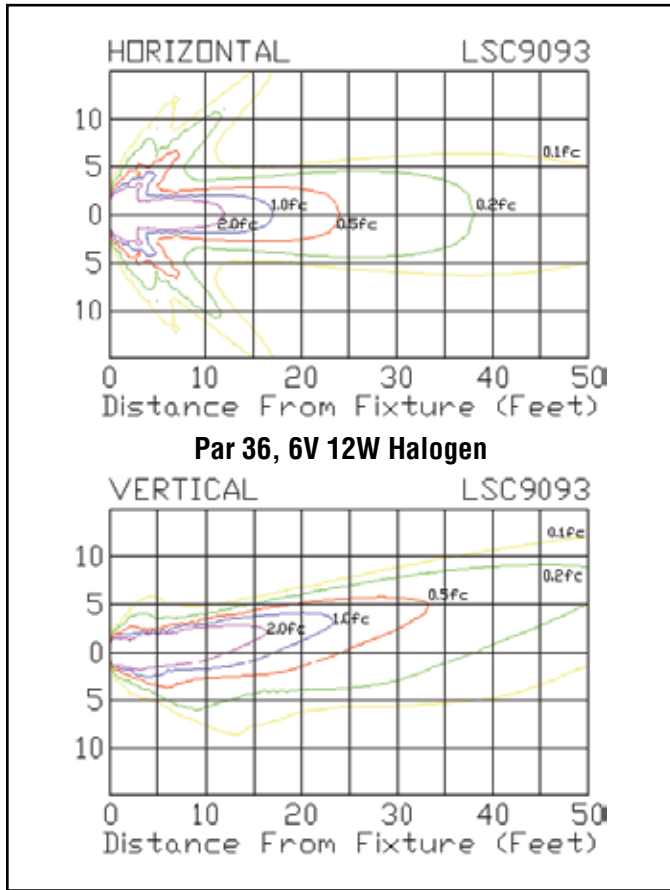

Ceiling mounted fixture

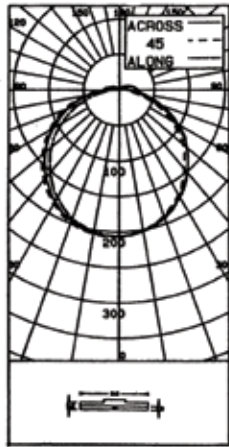

CANDLEPOWER SUMMARY		OUTPUT LUMENS			
ANGLE	ALONG	22.5	45	67.5	ACROSS
0	206	206	206	206	206
5	205	206	205	205	205
10	202	203	203	203	203
15	197	199	199	199	199
20	192	193	193	193	193
25	184	186	186	186	186
30	174	177	177	177	177
35	164	166	167	167	166
40	152	154	155	156	155
45	139	141	143	144	144
50	125	127	130	130	129
55	111	113	116	118	115
60	94	98	100	104	100
65	78	81	85	88	84
70	61	65	68	72	68
75	44	48	52	56	57
80	30	32	37	41	42
85	18	20	26	31	25
90	12	14	19	23	25
95	10	12	16	21	22
100	9	11	14	18	20
105	6	9	11	16	17
110	0	2	8	11	12
115	0	1	6	9	10
120	0	1	4	7	8
125	0	1	4	6	7
130	0	0	3	5	6
135	0	0	2	4	5
140	0	0	2	3	4
145	0	0	2	3	4
150	0	0	2	3	4
155	0	0	1	2	3
160	0	0	1	2	3
165	0	0	1	2	3
170	0	0	0	1	2
175	0	0	0	0	1
180	0	0	0	0	0

ZONE	LUMENS	% LAMP	ALUMINAIRE
0-30	161	13.93	23.39
0-40	265	21.27	38.49
0-60	478	38.32	69.33
0-90	645	51.66	93.67
40-90	379	30.38	54.98
60-90	166	13.34	24.14
90-180	45	3.61	6.53
0-180	690	55.27	100.00

** EFFICIENCY = 55.3% **

LUMINANCE SUMMARY - CD. / SQ. M.

ANGLE	ALONG	45	ACROSS
45	3288	3272	3427
55	3096	3080	3144
65	2764	2806	3150
75	2239	2367	2910
85	1685	1982	2954

CERTIFIED BY:

PREPARED FOR:

BEHELLI INC.
JACKSONVILLE, FLORIDA

S/MH = 1.3

SC = 1.3

DATE:

MAR 9, 1990

TESTED ACCORDING TO IES PROCEDURES. TEST DISTANCE = 7.9 METERS (26.0 FT.)

COEFFICIENTS OF UTILIZATION

ZONAL CAVITY METHOD

EFFECTIVE FLOOR CAVITY REFLECTANCE = .20

CC WALL	80		70		50		30		100						
	70	50	30	10	70	50	30	10	50	30	10	50	30	10	0
0	.65	.65	.65	.65	.63	.63	.63	.63	.59	.59	.59	.56	.56	.56	.53
1	.59	.56	.54	.52	.57	.55	.53	.51	.52	.50	.48	.49	.48	.46	.47
2	.56	.49	.46	.43	.52	.48	.45	.42	.45	.43	.40	.43	.41	.39	.41
3	.49	.43	.39	.35	.47	.42	.38	.35	.40	.37	.34	.38	.35	.33	.36
4	.45	.39	.34	.30	.44	.38	.33	.30	.36	.32	.29	.34	.31	.28	.33
5	.42	.35	.30	.26	.40	.34	.29	.26	.32	.28	.25	.31	.27	.24	.29
6	.38	.31	.26	.23	.37	.30	.26	.22	.29	.25	.22	.27	.24	.21	.26
7	.35	.28	.23	.20	.34	.27	.22	.19	.26	.22	.19	.25	.21	.18	.24
8	.32	.25	.20	.17	.31	.24	.20	.17	.23	.19	.17	.22	.19	.16	.22
9	.30	.23	.18	.15	.29	.22	.18	.15	.21	.17	.15	.20	.17	.14	.20
10	.28	.21	.16	.13	.27	.20	.16	.13	.19	.16	.13	.19	.15	.13	.18

DETERMINED IN ACCORDANCE WITH CURRENT IES PUBLISHED PROCEDURES

CANDLEPOWER DATA

ANGLE	FLAME					AVERAGE	OUTPUT LUMENS
	ALONG	22.5	45	67.5	ACROSS		
0	206	206	206	206	206	206	206
5	205	206	205	205	205	205	20
10	202	203	203	203	203	203	57
15	197	199	199	199	198	199	86
20	192	193	193	194	193	193	105
25	184	186	186	186	186	186	111
30	174	177	177	177	177	177	163
35	164	166	167	167	167	166	184
40	152	154	155	156	156	155	209
45	139	141	143	144	144	142	229
50	125	127	130	130	129	129	259
55	111	113	116	117	118	115	299
60	94	98	100	103	104	100	349
65	78	81	85	88	88	84	409
70	61	65	68	72	72	68	469
75	44	48	52	56	57	52	529
80	30	32	37	41	42	36	589
85	18	20	26	29	31	25	609
90	12	14	19	23	25	19	629
95	10	12	16	21	22	16	649
100	9	11	14	18	20	14	669
105	6	9	11	16	17	12	689
110	0	5	9	13	14	9	709
115	0	2	8	11	12	7	729
120	0	1	6	9	10	5	749
125	0	1	4	7	8	4	769
130	0	1	4	6	7	4	789
135	0	0	3	5	6	3	809
140	0	0	3	5	5	2	829
145	0	0	2	4	4	2	849
150	0	0	2	3	4	2	869
155	0	0	1	2	3	1	889
160	0	0	1	2	2	1	909
165	0	0	1	2	2	1	929
170	0	0	0	1	1	0	949
175	0	0	0	0	0	0	969
180	0	0	0	0	0	0	989

AVERAGE LUMINANCE DATA

ANGLE	CD. / SQ. M. (FOOTLAMBERTS)				
	ALONG	22.5	45	67.5	ACROSS
0	3836(1119)	3836(1119)	3836(1119)	3836(1119)	3836(1119)
30	3519(1027)	3516(1026)	3507(1023)	3533(1031)	3573(1043)
40	3379(986)	3348(977)	3334(973)	3397(991)	3476(1014)
45	3288(959)	3249(948)	3272(955)	3326(970)	3427(1000)
50	3200(934)	3148(919)	3181(928)	3239(945)	3343(975)
55	3096(903)	3049(889)	3080(899)	3177(927)	3344(976)
60	2926(854)	2917(851)	2943(858)	3095(903)	3247(947)
65	2764(806)	2729(796)	2806(819)	2975(868)	3150(919)
70	2552(745)	2521(736)	2613(762)	2838(828)	3027(883)
75	2239(653)	2234(652)	2367(690)	2642(771)	2910(849)
80	1945(567)	1889(551)	2110(616)	2420(706)	2792(815)
85	1685(491)	1599(466)	1982(578)	2345(684)	2954(862)

DETERMINED IN ACCORDANCE WITH CURRENT IES PUBLISHED PROCEDURES

Wall mounted fixture

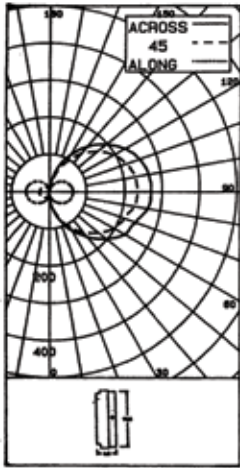

CANDLEPOWER SUMMARY		BEAM SIDE				OUTPUT LUMENS			
ANGLE	ALONG	22.5	45	67.5	ACROSS	0	11	11	11
0	11	11	11	11	11	11	11	11	11
5	12	13	25	16	27	1			
15	19	30	59	51	63	6			
25	28	51	95	92	104	18			
35	35	72	127	135	140	33			
45	43	92	157	174	179	52			
55	51	110	185	210	215	71			
65	57	124	204	238	235	88			
75	61	133	217	259	253	102			
85	63	137	232	284	270	111			
90	63	141	234	286	270				
95	63	142	232	283	270	112			
105	60	133	224	268	262	104			
115	54	119	208	242	244	89			
125	48	101	184	207	215	70			
135	39	78	151	167	179	49			
145	30	55	114	122	137	29			
155	21	32	75	76	96	14			
165	13	13	40	31	53	4			
175	6	4	10	4	13	0			
180	4	4	4	4	4	0			

ZONE	LUMENS	% LAMP	% LUMINAIRE
0-30	31	1.72	2.83
0-40	70	3.92	6.42
0-60	214	11.90	19.52
0-90	559	31.09	50.99
40-90	489	27.17	44.57
60-90	345	19.19	31.47
90-180	537	29.88	49.01
0-180	1097	60.97	100.00

** EFFICIENCY = 61.0% **

LUMINAIRE SUMMARY - CD. / SQ. M.

ANGLE	ALONG	45	ACROSS
45	994	4735	28833
55	1037	5004	38851
65	1089	5180	49840
75	1130	5329	47185
85	1133	5487	100379

S/ME = 6.8
SC (ALONG) = 3.8, SC (ACROSS) = 6.8

CERTIFIED BY: *[Signature]* DATE: MAR 6, 1990
PREPARED FOR: BREGHELLI INC.
JACKSONVILLE, FLORIDA

TESTED ACCORDING TO IES PROCEDURES. TEST DISTANCE = 7.9 METERS (26.0 FT.)

COEFFICIENTS OF UTILIZATION

ZONAL CAVITY METHOD
EFFECTIVE FLOOR CAVITY REFLECTANCE = .20

CC MALL	80				70				50				30				100				
	70	50	30	10	70	50	30	10	50	30	10	50	30	10	50	30	10	50	30	10	0
0	.65	.65	.65	.65	.60	.60	.60	.60	.51	.51	.51	.43	.43	.43	.35	.35	.35	.31			
1	.57	.53	.49	.46	.52	.48	.45	.42	.40	.38	.35	.33	.31	.29	.26	.24	.23	.20			
2	.50	.44	.39	.34	.46	.40	.35	.32	.33	.29	.26	.27	.24	.21	.21	.18	.17	.14			
3	.45	.37	.32	.27	.41	.34	.29	.25	.28	.24	.21	.22	.19	.17	.17	.15	.13	.10			
4	.41	.32	.27	.22	.37	.30	.24	.20	.24	.20	.17	.19	.16	.13	.15	.12	.10	.08			
5	.37	.28	.22	.18	.33	.26	.20	.17	.21	.17	.14	.17	.13	.11	.13	.10	.08	.06			
6	.34	.25	.19	.15	.30	.23	.17	.14	.19	.14	.11	.15	.11	.09	.11	.08	.06	.05			
7	.31	.22	.16	.13	.28	.20	.15	.11	.16	.12	.09	.13	.10	.07	.10	.07	.05	.03			
8	.28	.20	.14	.11	.26	.18	.13	.10	.15	.11	.08	.12	.08	.06	.09	.06	.04	.03			
9	.26	.18	.13	.09	.24	.16	.12	.08	.13	.09	.07	.11	.07	.05	.08	.05	.04	.02			
10	.24	.16	.11	.08	.22	.15	.10	.07	.12	.08	.06	.10	.06	.04	.07	.05	.03	.02			

DETERMINED IN ACCORDANCE WITH CURRENT IES PUBLISHED PROCEDURES

BEAM SIDE AVERAGE LUMINANCE DATA

ANGLE	CD. / SQ. M. (FOOTLAMBERTS)				
	ALONG	22.5	45	67.5	ACROSS
0	1679(490)	1679(490)	1679(490)	1679(490)	1679(490)
30	943(275)	1944(567)	4307(1257)	6605(1927)	17830(5204)
40	977(285)	2147(626)	4565(1332)	7807(2278)	24554(7166)
45	994(290)	2241(654)	4735(1382)	8296(2421)	28833(8415)
50	1022(298)	2314(675)	4892(1427)	8814(2572)	33429(9756)
55	1037(302)	2382(695)	5004(1460)	9260(2702)	38851(11339)
60	1066(311)	2437(711)	5106(1490)	9677(2824)	44614(13021)
65	1085(316)	2491(727)	5180(1512)	10064(2937)	49840(14546)
70	1093(319)	2538(740)	5256(1534)	10451(3050)	56793(16576)
75	1110(324)	2583(754)	5329(1555)	10810(3155)	67185(19609)
80	1123(328)	2606(760)	5596(1633)	11522(3362)	81555(23803)
85	1133(330)	2639(770)	5687(1660)	12079(3525)	100379(29297)

DETERMINED IN ACCORDANCE WITH CURRENT IES PUBLISHED PROCEDURES

OPPOSITE SIDE TO BEAM AVERAGE LUMINANCE DATA

ANGLE	CD. / SQ. M. (FOOTLAMBERTS)				
	ALONG	22.5	45	67.5	ACROSS
0	1679(490)	1679(490)	1679(490)	1679(490)	1679(490)
30	943(275)	874(255)	677(197)	590(172)	799(233)
40	977(285)	860(251)	681(198)	527(154)	721(210)
45	994(290)	885(258)	704(205)	508(148)	704(205)
50	1022(298)	884(258)	714(208)	479(139)	656(191)
55	1037(302)	886(258)	692(201)	441(128)	580(169)
60	1066(311)	884(258)	674(196)	430(125)	468(136)
65	1085(316)	889(259)	684(199)	402(117)	438(128)
70	1093(319)	884(258)	682(199)	385(112)	157(75)
75	1110(324)	885(258)	677(197)	385(112)	164(47)
80	1123(328)	885(258)	671(195)	372(108)	0(0)
85	1133(330)	887(259)	676(197)	377(110)	0(0)

DETERMINED IN ACCORDANCE WITH CURRENT IES PUBLISHED PROCEDURES

BEAM SIDE CANDLEPOWER DATA

ANGLE	FLANE				ACROSS	AVERAGE	OUTPUT LUMENS
	ALONG	22.5	45	67.5			
0	11	11	11	11	11	11	
5	12	13	25	16	27	18	1
10	15	20	41	32	44	31	
15	19	30	59	51	63	45	7
20	23	40	77	71	83	60	
25	28	51	95	92	104	76	18
30	31	61	113	114	122	91	
35	35	72	127	135	140	105	34
40	40	82	142	155	159	120	
45	43	92	157	174	179	134	52
50	47	101	172	193	198	147	
55	51	110	185	210	215	159	72
60	54	117	196	225	231	170	
65	57	124	204	238	235	178	89
70	59	129	211	250	243	185	
75	61	133	217	259	253	191	102
80	62	136	229	274	265	201	
85	63	137	232	284	270	205	112
90	63	141	234	286	270	207	
95	63	142	232	283	270	206	112
100	61	139	229	276	267	202	
105	60	133	224	268	262	196	104
110	57	127	217	256	254	189	
115	54	119	208	242	244	180	89
120	51	111	197	226	231	169	
125	48	101	184	207	215	156	70
130	43	90	168	188	198	142	
135	39	78	151	167	179	126	49
140	34	67	133	145	158	110	
145	30	55	114	122	137	93	30
150	25	43	93	99	114	76	
155	21	32	75	76	96	60	14
160	17	21	59	52	75	45	
165	13	13	40	31	53	29	5
170	9	7	23	14	31	16	
175	6	4	10	4	13	7	1
180	4	4	4	4	4	4	

OPPOSITE SIDE TO BEAM CANDLEPOWER DATA

ANGLE	FLANE				ACROSS	AVERAGE	OUTPUT LUMENS
	ALONG	22.5	45	67.5			
0	11	11	11	11	11	11	
5	12	11	9	8	8	10	1
10	15	14	10	9	7	11	
15	19	17	12	9	7	13	2
20	23	21	14	9	6	15	
25	28	24	16	10	7	17	4
30	31	28	18	10	5	18	
35	35	31	20	10	6	21	7
40	40	33	21	10	5	22	
45	43	37	23	11	4	24	10
50	47	39	25	10	4	25	
55	51	41	26	10	3	26	12
60	54	42	26	10	2	27	
65	57	44	27	10	2	28	14
70	59	45	27	9	1	28	
75	61	46	28	9	1	28	15
80	62	46	27	9	0	28	
85	63	46	28	9	0	29	16
90	63	45	27	8	0	28	
95	63	45	27	7	0	28	16
100	61	45	26	8	0	27	
105	60	44	25	7	0	26	15
110	57	43	25	7	0	26	
115	54	41	23	7	0	25	13
120	51	39	23	6	0	24	
125	48	37	21	6	0	22	10
130	43	35	20	5	0	21	
135	39	32	18	5	1	19	8
140	34	29	16	5	1	17	
145	30	26	14	4	1	15	5
150	25	22	12	4	2	13	
155	21	19	10	4	1	11	3
160	17	15	8	3	2	9	
165	13	13	6	3	2	7	2
170	9	9	5	3	3	6	
175	6	6	4	3	3	4	1
180	4	4	4	4	4	4	

Wall mounted fixture

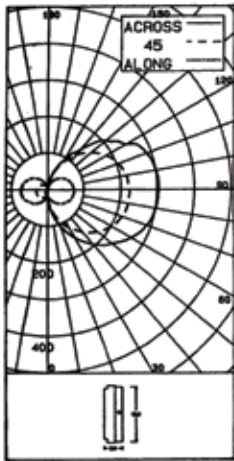

ANGLE	CANDLEPOWER SUMMARY BEAM SIDE				OUTPUT LUMENS
	ALONG	22.5	45	67.5	
0	24	24	24	24	24
5	22	25	35	27	40
15	28	39	69	64	84
25	37	58	104	108	129
35	45	78	133	151	172
45	53	96	165	191	215
55	62	113	190	227	246
65	68	126	210	257	277
75	72	135	220	277	295
85	73	139	223	288	303
90	72	142	222	279	304
95	71	142	220	264	303
105	68	133	212	248	295
115	62	118	196	224	277
125	54	98	172	191	230
135	44	76	141	153	181
145	33	52	105	111	122
155	23	30	71	67	78
165	14	12	35	27	40
175	6	4	8	4	9
180	4	4	4	4	4

ZONE	LUMENS	% LAMP	LUMINAIRE
0-30	39	2.19	3.45
0-40	85	4.73	7.43
0-60	244	13.59	21.34
0-90	613	34.08	53.53
40-90	528	29.35	46.10
60-90	368	20.49	32.13
90-180	532	29.58	46.47
0-180	1145	63.66	100.00

** EFFICIENCY = 63.7% **

LUMINANCE SUMMARY - CD. / SQ. M.

ANGLE	ALONG	45	ACROSS
45	1234	5007	37214
55	1266	5212	47693
65	1287	5360	62925
75	1311	5426	84306
85	1322	5484	121139

SC(ALONG) = 2.8, SC(ACROSS) = 5.4

CERTIFIED BY: *[Signature]* DATE: MAR 6, 1990
 PREPARED FOR: BEGHELLI INC. JACKSONVILLE, FLORIDA

TESTED ACCORDING TO IES PROCEDURES. TEST DISTANCE = 7.9 METERS (26.0 FT.)

COEFFICIENTS OF UTILIZATION

ZONAL CAVITY METHOD
 EFFECTIVE FLOOR CAVITY REFLECTANCE = .20

CCR	COEFFICIENTS OF UTILIZATION																	
	80				70				50				30					
0	.69	.69	.69	.69	.64	.64	.64	.64	.54	.54	.54	.46	.46	.46	.38	.38	.38	.34
1	.59	.55	.51	.48	.55	.51	.47	.44	.43	.40	.38	.35	.33	.31	.28	.27	.25	.22
2	.53	.46	.41	.36	.48	.42	.37	.33	.35	.31	.28	.29	.26	.23	.23	.20	.18	.15
3	.47	.39	.33	.28	.43	.36	.31	.26	.30	.26	.22	.24	.21	.18	.19	.16	.14	.11
4	.43	.34	.28	.23	.39	.31	.26	.21	.26	.21	.18	.21	.17	.15	.16	.14	.11	.09
5	.39	.29	.24	.19	.35	.27	.22	.17	.23	.18	.15	.18	.15	.12	.14	.11	.09	.07
6	.35	.26	.20	.16	.32	.24	.18	.14	.20	.15	.12	.16	.12	.10	.12	.09	.07	.05
7	.32	.23	.17	.13	.29	.21	.16	.12	.18	.13	.10	.14	.11	.08	.11	.08	.06	.04
8	.30	.21	.15	.11	.27	.19	.14	.10	.16	.12	.09	.13	.09	.07	.10	.07	.05	.03
9	.27	.19	.13	.10	.25	.17	.12	.09	.14	.10	.07	.11	.08	.06	.09	.06	.04	.03
10	.25	.17	.12	.08	.23	.15	.11	.08	.13	.09	.06	.10	.07	.05	.08	.05	.03	.02

DETERMINED IN ACCORDANCE WITH CURRENT IES PUBLISHED PROCEDURES

BEAM SIDE AVERAGE LUMINANCE DATA

ANGLE	CD. / SQ. M. (FOOTLAMBERTS)			
	ALONG	22.5	45	67.5
0	3806(1111)	3806(1111)	3806(1111)	3806(1111)
30	1242(362)	2185(637)	4684(1367)	7691(2344)
40	1225(357)	2296(670)	4879(1424)	8844(2581)
45	1234(360)	2357(688)	5007(1461)	9298(2713)
50	1247(364)	2413(704)	5138(1499)	9776(2853)
55	1266(369)	2466(720)	5212(1521)	10201(2977)
60	1268(370)	2521(735)	5288(1543)	10614(3098)
65	1287(375)	2562(747)	5360(1564)	10998(3210)
70	1301(379)	2599(758)	5398(1575)	11362(3316)
75	1311(382)	2630(767)	5426(1583)	11707(3416)
80	1308(381)	2657(775)	5467(1595)	12021(3508)
85	1322(385)	2684(783)	5484(1600)	12342(3602)

DETERMINED IN ACCORDANCE WITH CURRENT IES PUBLISHED PROCEDURES

OPPOSITE SIDE TO BEAM AVERAGE LUMINANCE DATA

ANGLE	CD. / SQ. M. (FOOTLAMBERTS)			
	ALONG	22.5	45	67.5
0	3806(1111)	3806(1111)	3806(1111)	3806(1111)
30	1242(362)	1124(328)	986(288)	1027(299)
40	1225(357)	1071(312)	934(272)	904(264)
45	1234(360)	1058(308)	894(261)	848(247)
50	1247(364)	1049(306)	862(257)	789(230)
55	1266(369)	1039(303)	832(251)	728(212)
60	1268(370)	1031(301)	838(246)	688(201)
65	1287(375)	1023(298)	825(240)	661(193)
70	1301(379)	1016(296)	826(241)	641(187)
75	1311(382)	1017(297)	808(235)	627(183)
80	1308(381)	1000(291)	799(233)	596(174)
85	1322(385)	1008(294)	782(228)	584(170)

DETERMINED IN ACCORDANCE WITH CURRENT IES PUBLISHED PROCEDURES

BEAM SIDE CANDLEPOWER DATA

ANGLE	FLAME				ACROSS	AVERAGE	OUTPUT LUMENS
	ALONG	22.5	45	67.5			
0	24	24	24	24	24	24	24
5	22	25	35	27	40	30	2
15	28	39	69	64	84	42	9
20	32	48	86	85	107	72	21
25	37	58	104	108	129	88	37
30	41	68	119	129	151	103	57
35	45	78	133	151	172	118	77
40	49	87	150	172	195	133	95
45	53	96	165	191	215	146	114
50	58	105	179	210	228	159	134
55	62	113	190	227	246	171	154
60	64	120	201	243	263	182	174
65	68	126	210	257	277	191	194
70	70	131	216	268	287	199	214
75	72	135	220	277	295	204	234
80	72	138	223	284	300	208	254
85	73	139	223	288	303	210	274
90	72	142	222	279	304	208	294
95	71	142	220	264	303	203	314
100	69	138	217	258	300	199	334
105	68	133	212	248	295	194	354
110	65	126	205	237	287	186	374
115	62	118	196	224	277	177	394
120	58	109	185	209	247	164	414
125	54	98	172	191	230	151	434
130	49	88	157	173	208	137	454
135	44	76	141	153	181	121	474
140	38	64	123	133	144	103	494
145	33	52	105	111	122	87	514
150	28	41	84	89	95	69	534
155	23	30	71	67	78	55	554
160	19	20	52	46	58	39	574
165	14	12	35	27	40	25	594
170	10	7	19	11	23	13	614
175	6	4	8	4	9	6	634
180	4	4	4	4	4	4	654

OPPOSITE SIDE TO BEAM CANDLEPOWER DATA

ANGLE	FLAME				ACROSS	AVERAGE	OUTPUT LUMENS
	ALONG	22.5	45	67.5			
0	24	24	24	24	24	24	24
5	22	21	21	20	19	21	2
10	24	22	19	17	16	19	3
15	28	25	20	17	15	21	9
20	32	28	21	18	15	23	21
25	37	32	24	18	13	25	37
30	41	35	25	17	12	26	57
35	45	38	27	18	11	28	77
40	49	41	29	18	10	29	95
45	53	43	29	17	8	30	114
50	58	46	31	17	6	31	134
55	62	48	32	16	5	32	154
60	64	49	32	16	4	33	174
65	68	51	32	15	3	33	194
70	70	51	33	15	2	34	214
75	72	52	33	15	2	34	234
80	72	52	33	14	1	34	254
85	73	52	32	14	0	34	274
90	72	50	30	12	0	32	294
95	71	49	28	10	0	31	314
100	69	49	28	10	0	30	334
105	68	48	27	9	0	30	354
110	65	47	26	9	0	29	374
115	62	45	26	8	0	28	394
120	58	43	24	8	0	26	414
125	54	41	22	8	0	24	434
130	49	38	21	7	0	23	454
135	44	35	19	7	0	21	474
140	38	31	18	6	0	18	494
145	33	28	15	6	0	16	514
150	28	24	13	5	0	14	534
155	23	20	11	4	0	12	554
160	19	16	8	4	0	10	574
165	14	13	6	4	0	7	594
170	10	9	5	4	0	6	614
175	6	6	4	3	0	4	634
180	4	4	4	4	0	4	654

TERMS & CONDITIONS

ACCEPTANCE

A contract shall be formed when acceptance of the Purchaser's order is confirmed in writing by [Beghelli USA](#). All purchase orders are accepted and executed on the understanding that the Purchaser is bound by these Terms & Conditions. Where there is any inconsistency between these Conditions and any conditions that the Purchaser seeks to impose, these Conditions shall prevail. These Conditions, together with any special terms and conditions agreed in writing by the parties, and any documents referred to in Conditions or elsewhere in the contract, shall constitute the entire agreement between [Beghelli USA](#) and the purchasers and supersede an previous agreement or arrangement between them relating to the subject matter thereof. This Contract may not be amended or varied except in writing duly executed by an authorized officer of [Beghelli USA](#).

PAYMENT TERMS

Upon credit approval, [Beghelli USA](#) customer payment terms are scheduled as NET-30 days from the date of the invoice. Any payment not received within the set terms shall be considered late and past-due contractual terms of payment. Past due invoices shall be subject to an interest rate charge of 1-1.5% per month, or fraction thereof, or the maximum permitted by law, whichever is less. In the event that it becomes a necessity for [Beghelli USA](#) to employ an attorney or incur other costs in relation to the collection of past-due payments, the customer agrees to pay all reasonable costs incurred for such collection.

PRICING

All pricing is set by [Beghelli USA](#) and are Net F.O.B. factory (point of shipment origin). The amount of any applicable sales tax, excise duty or levy shall be added to the billing unless appropriate exemption certificates are provided to [Beghelli USA](#). The purchaser shall indemnify and hold harmless [Beghelli USA](#) in respect to any loss, cost or expense incurred by the Company as a result of, directly or indirectly, of the Purchaser's instruction or through any delay whatsoever in taking delivery or through any other act, neglect or fault on the part of the Purchaser, its servants, agents or employees. The price of the Goods shall be due in full to the Company in accordance with the terms of the Contract and the Purchaser shall not be entitled to exercise any set-off, lien or any similar right or claim. All prices and terms are subject to change without notice.

TECHNICAL INFORMATION AND ILLUSTRATIONS

All descriptive specifications, drawings and particulars of weights and dimensions issued by [Beghelli USA](#) are approximated only and are intended only to present a general idea of the goods to which they refer and shall not form part of the contract. Any data, technical information or performance data provided by [Beghelli USA](#) are based on tests performed under standard conditions and cannot be guaranteed under different conditions. [Beghelli USA](#) may make any changes in the specifications of goods as required to conform with any applicable safety or electrical code requirements and/or do not materially affect their quality or performance.

DELIVERY SCHEDULE

Upon receipt of purchase orders, [Beghelli USA](#) assigns scheduled shipment dates if not specified on the standing order. The times quoted are to be treated as estimates only. In all cases, whether a shipment time is quoted or not, the times for shipment shall be extended by a reasonable period if delay in shipment is caused by instructions or lack of instructions from the Purchaser, or by industrial dispute, or by any cause whatsoever beyond [Beghelli USA's](#) reasonable control. [Beghelli USA](#) shall not be liable for delays in delivery due to causes beyond our reasonable control. Severe weather conditions, fires, strikes, floods, delays of carriers or delays arising from labor difficulties, shortages, stoppages or any sort can all effect the estimated delivery time.

FREIGHT ALLOWANCE

All shipments are F.O.B. factory or point of shipment origin. Title passes to purchaser upon delivery by us to the carrier, and all claims for damages or shortages in transit shall be made by the purchaser with delivering carrier. All orders for product having a distributor price of \$1500.00 or more for one shipment to one location qualify for freight allowance. All orders less than a \$1500.00 distributor price will be assessed freight and handling charges. [Beghelli](#) freight allowance is not offered on AC Standby (Inverter) systems. For all orders that qualify for freight allowance, [Beghelli USA](#) reserves the right to select the carrier and to route shipments at our discretion. We will ship in the manner selected by the purchaser provided the purchaser assumes any additional transportation costs. Any and all claims related to loss, shortage, breakage or shipping errors of product received shall be reported in writing within 5 days of receipt of delivery.

RETURN OF GOODS

No merchandise may be returned without written prior authorization from [Beghelli USA](#). At [Beghelli USA's](#) discretion, Emergency lighting and exit signs shown in the current catalog can be returned for credit provided they are in unused, mint condition and are in the original, factory sealed packaging. Requests to return product must be made with one of our agents for transmittal to [Beghelli USA](#) within 12 months from the date of shipment by us. When requesting the RGA, the purchaser's name, original purchase order number and reason for request must be submitted. RGA's are valid for 30 days. Returned goods must be received by [Beghelli](#) within the 30 days or the RGA becomes void. Transportation charges must be prepaid. To preserve the return, all returned product must be properly packed to prevent shipping damage. The factory issued RGA number must be clearly marked and visible on the exterior packaging. Goods returned without a valid RGA cannot be accepted and will be redirect to the purchaser, at the purchaser's expense. [Beghelli USA](#) will notify customer accordingly. If a part is damaged or lost during transit, the purchaser is responsible for directing a claim to carrier.

All stock products containing time sensitive components that have reached the end of their warranty or shelf life are not returnable. All non-stockings, special, custom made and modified products are not returnable. Outdated or phase-out stock products are also non-returnable. Returned goods that are not defective are subject to a standard restocking fee. All product returns are subject to inspection and approval. Returned goods that are not defective are subject to a standard minimum restocking fee of 35%.

PRODUCT WARRANTY

[Beghelli USA](#) warrants all products and hereunder to be free from defect in manufacturing, under normal and proper storage, installation and use for a period of five (5) years from the date of purchase unless otherwise specified (see inverters). [Beghelli USA's](#) warranty extends only to the repair or replacement of the defective part, and no labor charges for correction will be paid by [Beghelli USA](#) unless prior written authorization has been granted. The purchaser shall notify [Beghelli USA](#) within 5 working days of the date the defect became apparent. This warranty does not include batteries and lamps which have a fair wear and tear life-cycle based on shelf-life, use and maintenance. Furthermore, this warranty does not cover intentional physical abuse of the products, improper installation, installation in areas that the product is not listed/suitable and/or products that have been internally altered by an unauthorized service agent.

