

ILLUMINA HZ100

FLUORESCENT (T5)



T5 2' - 4'
Hazardous
Class 1, Div 2
Groups A-D
Wet/IP66



Suspended Luminaire

Application: ILLUMINA® HZ100T5 is a high performance luminaire that is rated for hazardous locations. Approved for installation in Class 1, Division 2, Groups A, B, C and D environments. The three piece design snaps together without the need of any tools. The HZ100T5 weighs a mere 6.5lbs and is available in 2ft or 4ft. Construction is 100% polycarbonate, which makes it corrosion, flame and vandal resistant. The ILLUMINA® HZ100T5 is ideal for prep and inspection areas, sanding and machining environments.

Type: _____

Project: _____

CONFIGURE:

a	MODEL	b	LENGTH	c	OPERATION	d	LAMPS	e	INPUT	f	OPTIONS
	HZ100T5 ILLUMINA® HZ100 T5 SERIES	2 2 foot 4 4 foot		HT AC only		114W 1x14W T5 214W 2x14W T5 128W 1x28W T5 228W 2x28W T5		120V 277V 120/277V 347V		FP inline fuse protection PK rigid pendant kit: 18", 24", 36" & 48" AC aviation cable: 50", 72", 100", 150" & 250" CH chain hang kit TP tamper proof	
	MODEL a	LENGTH b		OPERATION c		LAMPS d		INPUT e		OPTIONS f	
	HZ100T5										

NOTE: (AC & PK) length to be specified, i.e. PK24 or AC100

HOUSING: 100% UV stabilized polycarbonate material, integrated liquid silicone perimeter gasket with memory retention, recessed stainless steel mounting brackets.

REFLECTOR: Dual parabolic (2-lamp versions) and single parabolic (1-lamp versions) high emission reflector. Vacuum metallized finish. Direct mount reflector configuration supports all electrical components.

DIFFUSER: High performance diffuser. Complete light emission (CLE) technology. 100% Polycarbonate construction, impact resistant, UV stabilized to reduce yellowing index.

LAMP/SOCKET: Two (2) or four (4) T5 ratchet type sockets with Beghelli T5 adaptor extenders.

MOUNTING: Surface mount configuration as standard. Optional (AC) aviation cable, adjustable and

(PK) pendant mounting are available. Required mounting height to be specified.

POWER LINE/FEED: 3-wire, solid type 18awg, pre-stripped 12" leads for quick in-field connection.

WEIGHT: 6.5 lbs. / 2.948 kilo.

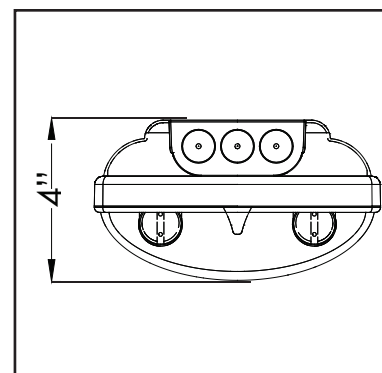
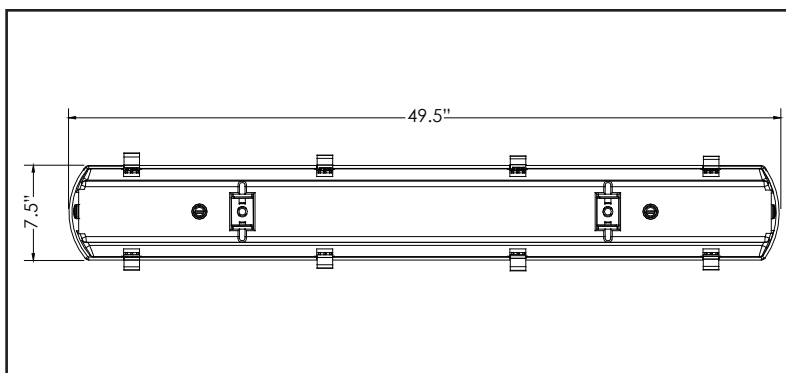

ILLUMINA

HZ100

FLUORESCENT (T5HO)



2' - 4'
Hazardous
Class 1, Div 2
Groups A-D
Wet/IP66



Suspended Luminaire

Application: The ILLUMINA® HZ100T5HO is a high performance luminaire that is rated for hazardous locations. Approved for installation in Class 1, Division 2, Groups A, B, C and D environments. The three piece design snaps together without the need of any tools. The HZ100T5HO weighs a mere 6.5lbs and is available in 2ft or 4ft. Construction is 100% polycarbonate, which makes it corrosion, flame and vandal resistant. The ILLUMINA® HZ100 T5 is ideal for prep and inspection areas, sanding and machining environments.

Type: _____

Project: _____

CONFIGURE:

a	b	c	d	e	f
MODEL	LENGTH	OPERATION	LAMPS	INPUT	OPTIONS
HZ100T5HO ILLUMINA® HZ100 T5HO SERIES	2 2 foot 4 4 foot	HT AC only	124W 1x24W T5HO 224W 2x24W T5HO 154W 1x54W T5HO 254W 2x54W T5HO	120V 277V 120/277V 347V	FP inline fuse protection PK rigid pendant kit: 18", 24", 36" & 48" AC aviation cable: 50", 72", 100", 150" & 250" CH chain hang kit TP tamper proof <small>NOTE: (AC & PK) length to be specified, i.e. PK24 or AC100</small>
MODEL a	LENGTH b	OPERATION c	LAMPS d	INPUT e	OPTIONS f
HZ100T5HO					

HOUSING: 100% UV stabilized polycarbonate material, integrated liquid silicone perimeter gasket with memory retention, recessed stainless steel mounting brackets.

REFLECTOR: Dual parabolic (2-lamp versions) and single parabolic (1-lamp versions) high emission reflector. Vacuum metallized finish. Direct mount reflector configuration supports all electrical components.

DIFFUSER: High performance diffuser. Complete light emission (CLE) technology. 100% Polycarbonate construction, impact resistant, UV stabilized to reduce yellowing index.

LAMP/SOCKET: Two (2) or four (4) T5 ratchet type sockets with Beghelli T5 adaptor extenders.

MOUNTING: Surface mount configuration as standard. Optional (AC) aviation cable, adjustable and

(PK) pendant mounting are available. Required mounting height to be specified.

POWER LINE/FEED: 3-wire, solid type 18awg, pre-stripped 12" leads for quick in-field connection.

WEIGHT: 6.5 lbs. / 2.948 kilo.

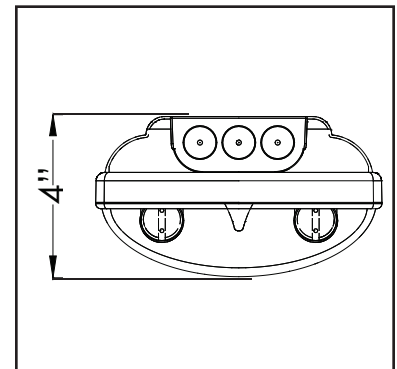
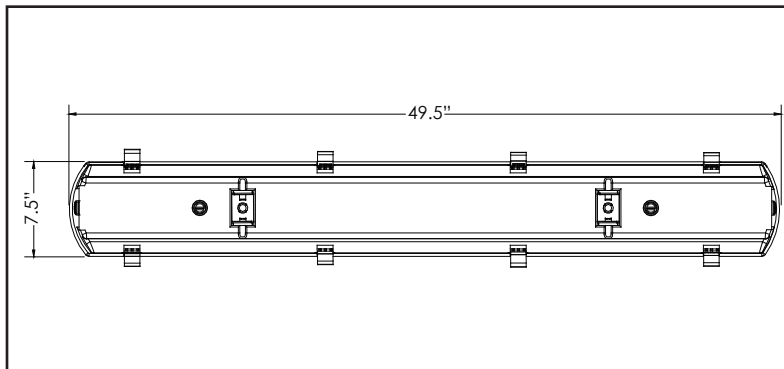

ILLUMINA

HZ100

FLUORESCENT (T8)



2' - 4'
Hazardous
Class 1, Div 2
Groups A-D
Wet/IP66



Suspended Luminaire

Application: The ILLUMINA® HZ100T8 is an efficient, performance based luminaire that is rated for hazardous locations. Approved for installation in Class 1, Division 2, Groups A, B, C and D environments. The three piece design snaps together without the need of any tools. The HZ100T8 weighs a mere 6.5lbs and is available in 2ft or 4ft. Construction is 100% polycarbonate, which makes it corrosion, flame and vandal resistant. The ILLUMINA® HZ100T8 is ideal for prep and inspection areas, sanding and machining environments.

Type: _____

Project: _____

CONFIGURE:

a	b	c	d	e	f
MODEL	LENGTH	OPERATION	LAMPS	INPUT	OPTIONS
HZ100T8 ILLUMINA® HZ100 T8 SERIES	2 2 foot 4 4 foot	HT AC only	117W 1x17W T8 217W 2x17W T8 132W 1x32W T8 232W 2x32W T8	120V 277V 120/277V 347V	FP inline fuse protection PK rigid pendant kit: 18", 24", 36" & 48" AC aviation cable: 50", 72", 100", 150" & 250" CH chain hang kit TP tamper proof <small>NOTE: (AC & PK) length to be specified, i.e. PK24 or AC100</small>
MODEL a	LENGTH b	OPERATION c	LAMPS d	INPUT e	OPTIONS f
HZ100T8					

HOUSING: 100% UV stabilized polycarbonate material, integrated liquid silicone perimeter gasket with memory retention, recessed stainless steel mounting brackets.

REFLECTOR: Dual parabolic (2-lamp versions) and single parabolic (1-lamp versions) high emission reflector. Vacuum metallized finish. Direct mount reflector configuration supports all electrical components.

DIFFUSER: High performance diffuser. Complete light emission (CLE) technology. 100% Polycarbonate construction, impact resistant, UV stabilized to reduce yellowing index.

LAMP/SOCKET: Two (2) or four (4) T8 ratchet type sockets.

MOUNTING: Surface mount configuration as standard. Optional (AC) aviation cable, adjustable and

(PK) pendant mounting are available. Required mounting height to be specified.

POWER LINE/FEED: 3-wire, solid type 18awg, pre-stripped 12" leads for quick in-field connection.

WEIGHT: 6.5 lbs. / 2.948 kilo.

